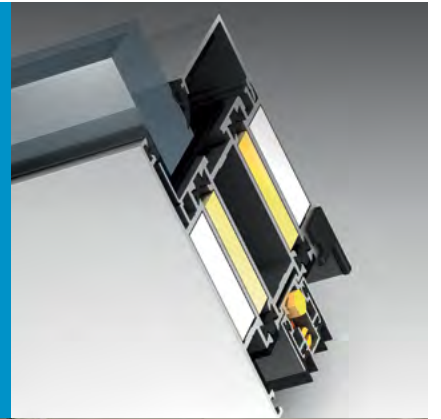




Profile systems

ALT FR76

Fire resistant doors
with double thermal break





ALT FR76
FIRE RESISTANT
DOORS WITH DOUBLE
THERMAL BREAK

CONTENTS

- 01 System description
- 02 Order information
- 03 Accessories
- 04 Table of glazing
- 05 Cross sections and joint solutions
- 06 Machining and assemblage of profiles
- 07 Example of standard system calculation
- 08 Hardware
- 09 Statics

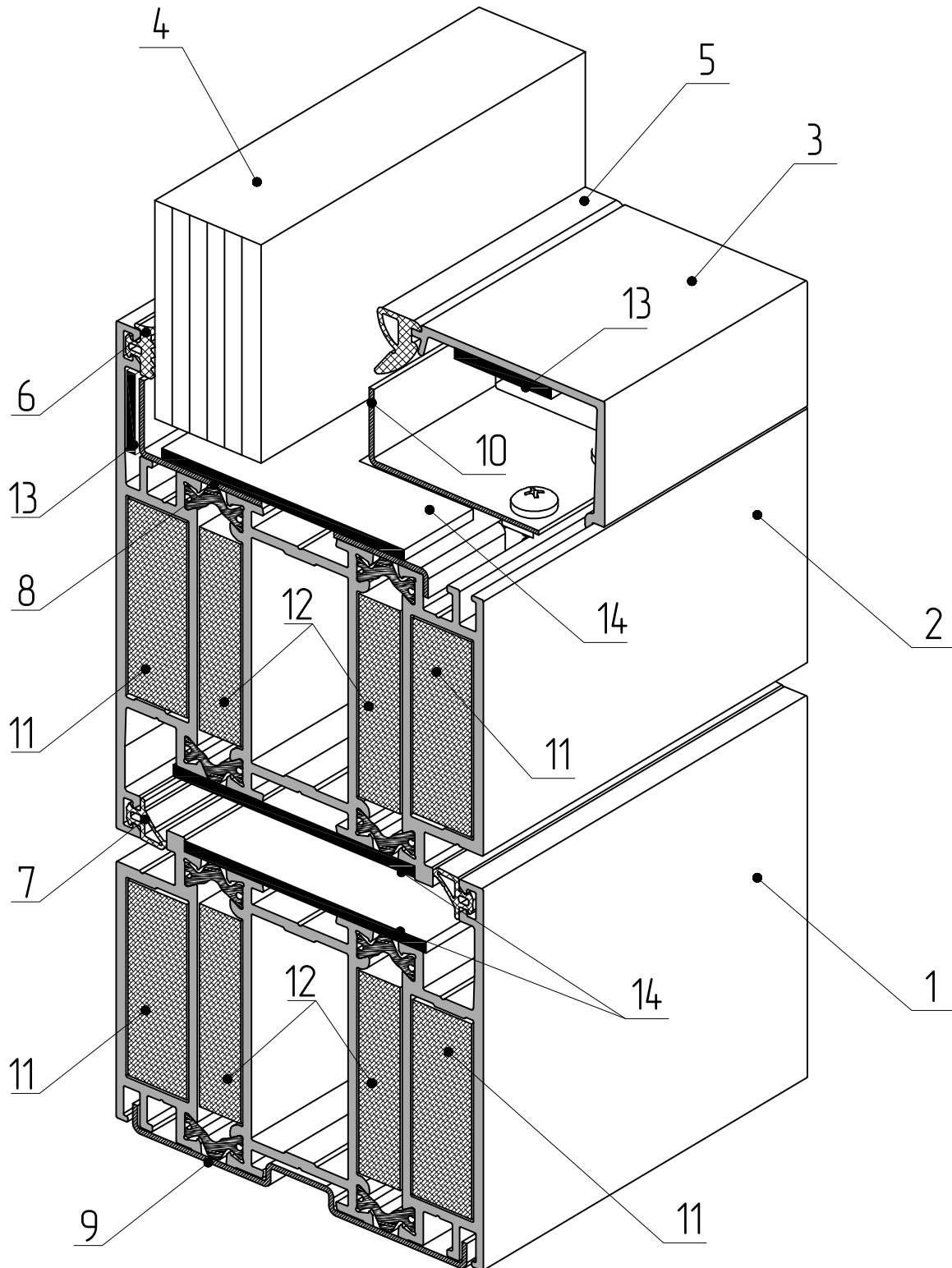


ALT FR76
FIRE RESISTANT
DOORS WITH DOUBLE
THERMAL BREAK

SYSTEM DESCRIPTION

01

FR76 Fire resistant door system



- 1 – AYPC.FR76.0101 frame profile
- 2 – AYPC.FR76.0201 door leaf profile
- 3 – AYPC.FR76.0608 glass bead profile
- 4 – fire resistant infill unit
- 5 – FRK36 rubber gasket
- 6 – FRK29-01 rubber gasket
- 7 – FRK148 rubber gasket

- 8 – AYPC.FR76.1002 steel holder
- 9 – AYPC.FR76.1001 steel holder
- 10 – AYPC.FR76.1010 steel holder
- 11 – AYPC.FR76.2001 fireproof insert
- 12 – AYPC.FR76.2002 fireproof insert
- 13 – LTU20x2 thermal sealing tape
- 14 – LTU50x2 thermal sealing tape

System description

ALT FR76 profile system is designed to fabricate fire resistant exterior and interior doors and partitions in buildings and premises with EIW30—EIW60 fireproof requirements.

ALT FR76 is specially designed to fabricate fire resistant units that allows to assemble EIW30 doors and partitions without using of any fireproof inserts.

Specially developed five-chamber profiles made of three aluminum profiles connected with two pairs of polyamide thermal breaks are used. This innovative solution allows to obtain same fire resistant parameters from both sides of a unit. The eurogroove in the middle aluminum part of the profile allows to install perimeter locking hardware and automatic threshold.

Advanced fire resistant performances of the ALT FR76 system are achieved due to the use of additional hardware and accessories:

1. Fire resistant insert kits are applied in EIW45 and EIW60 units only. The ergonomic shape of the inserts increases the speed of assembling and reduces machining and inserts installation cost.
2. The eurogroove 15/20 geometry with a possibility of perimeter locking use is designed in central part of the profiles. This design allows to apply multipoint locking. Fire resistant cover plates are not applied in case of perimeter locking.
3. Fire resistant cover plates are installed on door panel from hinges side and on its upper part in order to prevent door destruction in case of hinges burning-out. The W72.1010 cover plate is applicable only for doors without perimeter locking.
4. The butt end of door panel and frame, as well as the space under the infill unit seam and glass bead profile are covered on perimeter with a thermal sealing tape. Sealing tapes prevent warm gases, open fire and smoke penetration into the isolated room.
5. In order to ensure infill units fixation inside of the frame because of thermal expansion during the fire, steel fixing elements and corner connectors are to be installed on the frame perimeter as well as into the infill seam area. The installation of fixing elements doesn't make the door more complicated, no additional machining of profiles required.
6. Special supports made of hardwoods treated with a special fire resistant compound are to be installed additionally under the infill units in order to save their structure and bearing capacity.

Up to 50 mm fire resistant infill units are used in the ALT FR76 system.

All dimensions, weights and profiles characteristics mentioned in the catalog are theoretic and could be modified depending on profiles dimensions tolerances.

Materials used

Aluminum and combined profiles

Profiles are made of EN AW 6063 alloy in accordance with EN 12020-1, condition T6. The alloy is resistant to corrosion and permits the production of high precision profiles. Coating: QUALICOAT + SEASIDE certified powder coating, QUALANOD certified anodizing.

Gaskets

Rubber gaskets produced from ethylene-propylene rubber (EPDM) are used to seal infill units, window middle part, ensuring condensate removal and frame-sash connection.

Fixing elements

All the connectors and fasteners used for profiles, accessories and hardware connection should be made of stainless steel (A2 or A4).

Steel reinforcement elements

Steel holders and corner connectors used for profile chambers connection should be made of stainless steel EN 1.4301 IIID (X 5CrNi 1810).

Fireproof inserts

Fireproof inserts are intended to decrease the volume of warm air flow on protected side of the door. They are made of fire-resistant gypsum board, moisture-resistant gypsum board or glass magnesium board.

Wooden supports

Used to hold infill units after plastic supports deformation. Made of oak and treated with a fire resistant compound.

Thermal sealing tapes

Thermal sealing tape is an expanding graphite-based sealer. It expands and becomes 10 times larger under the fire.

Accessories

It is possible to use any kind of eurogroove hardware. The hardware should be selected according to the minimum requirements mentioned in this catalog.



ALT FR76

FIRE RESISTANT
DOORS WITH DOUBLE
THERMAL BREAK

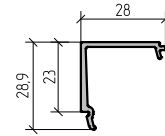
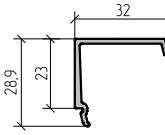
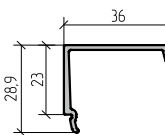
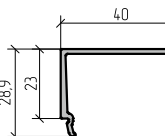
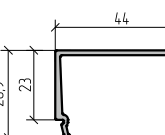
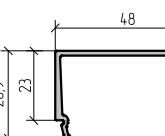
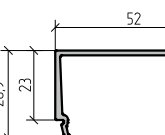
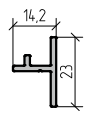
ORDER INFORMATION


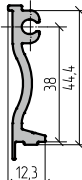
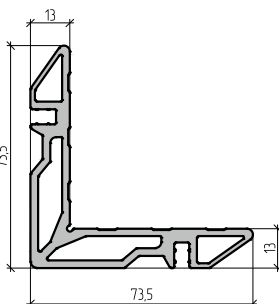
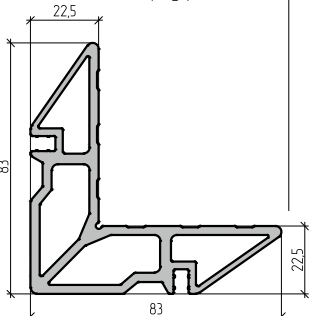
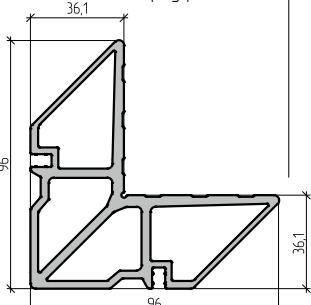
02

Article	Description Image	Weight, kg/m	Exterior perimeter, mm	Cross section area, mm ²	Code	Color	Bar length, m	Qty in pack,		Weight of pack	
								pcs	m	net, kg	gross, kg
AYPC.FR76.0101		2,72	469	1070	12300100 12300121 12300124 12300130 12300131 123001808	00 RAL9016 RAL8014 RAL8017 RAL9006 A00-D6	6,5	2	13	35,3 36,2 36,2 36,2 36,2 35,3	36,1 37,1 37,1 37,1 37,1 36,1
AYPC.FR76.0102		2,27	426	908	12300500 12300521 12300524 12300530 12300531 123005808	00 RAL9016 RAL8014 RAL8017 RAL9006 A00-D6	6,5	2	13	29,5 30,3 30,3 30,3 30,3 29,5	30,1 31,1 31,1 31,1 31,1 30,1
AYPC.FR76.0103		2,35	473	936	12300600 12300621 12300624 12300630 12300631 123006808	00 RAL9016 RAL8014 RAL8017 RAL9006 A00-D6	6,5	2	13	30,5 31,5 31,5 31,5 31,5 30,5	31,2 32,2 32,2 32,2 32,2 31,2
AYPC.FR76.0104		2,81	501	1106	12300700 12300721 12300724 12300730 12300731 123007808	00 RAL9016 RAL8014 RAL8017 RAL9006 A00-D6	6,5	2	13	36,5 37,5 37,5 37,5 37,5 36,5	37,3 38,4 38,4 38,4 38,4 37,3
AYPC.FR76.0105		4,62	645	1777	12300800 12300821 12300824 12300830 12300831 123008808	00 RAL9016 RAL8014 RAL8017 RAL9006 A00-D6	6,5	1	6,5	30 30,7 30,7 30,7 30,7 30	30,7 31,4 31,4 31,4 31,4 30,7

Article	Description Image	Weight, kg/m	Exterior perimeter, mm	Cross section area, mm ²	Code	Color	Bar length, m	Qty in pack,		Weight of pack	
								pcs	m	net, kg	gross, kg
AYPC.FR76.0120	<p>Widener profile</p>	2,2	413	883	12300900	00	6,5	2	13	28,6	29,2
					12300921	RAL9016				29,5	30,2
					12300924	RAL8014				29,5	30,2
					12300930	RAL8017				29,5	30,2
					12300931	RAL9006				29,5	30,2
					123009808	A00-D6				28,6	29,2
AYPC.FR76.0121	<p>Widener profile</p>	2,67	441	1054	12301000	00	6,5	2	13	34,7	35,5
					12301021	RAL9016				35,6	36,4
					12301024	RAL8014				35,6	36,4
					12301030	RAL8017				35,6	36,4
					12301031	RAL9006				35,6	36,4
					123010808	A00-D6				34,7	35,5
AYPC.FR76.0201	<p>Door leaf profile</p>	2,86	480	1123,1	12300200	00	6,5	2	13	37,1	37,9
					12300221	RAL9016				38,1	38,9
					12300224	RAL8014				38,1	38,9
					12300230	RAL8017				38,1	38,9
					12300231	RAL9006				38,1	38,9
					123002808	A00-D6				37,1	37,9
AYPC.FR76.0202	<p>Door leaf profile</p>	2,86	480	1123,1	12300300	00	6,5	2	13	37,1	37,9
					12300321	RAL9016				38,1	38,9
					12300324	RAL8014				38,1	38,9
					12300330	RAL8017				38,1	38,9
					12300331	RAL9006				38,1	38,9
					123003808	A00-D6				37,1	37,9
AYPC.FR76.0301	<p>Transom bar profile</p>	2,49	533	989	12301100	00	6,5	2	13	32,3	33
					12301121	RAL9016				33,4	34,2
					12301124	RAL8014				33,4	34,2
					12301130	RAL8017				33,4	34,2
					12301131	RAL9006				33,4	34,2
					123011808	A00-D6				32,3	33

Article	Description Image	Weight, kg/m	Exterior perimeter, mm	Cross section area, mm ²	Code	Color	Bar length, m	Qty in pack,		Weight of pack	
								pcs	m	net, kg	gross, kg
AYPC.FR76.0302	<p>Transom bar profile</p>	2,95	561	1159	12301200 12301221 12301224 12301230 12301231 123012808	00 RAL9016 RAL8014 RAL8017 RAL9006 A00-D6	6,5	2	13	38,3 39,4 39,4 39,4 39,4 38,3	39,1 40,3 40,3 40,3 40,3 39,1
AYPC.FR76.0801	<p>Threshold profile</p>	1,17	247	527	12301300 12301321 12301324 12301330 12301331 123013808	00 RAL9016 RAL8014 RAL8017 RAL9006 A00-D6	6,5	4	26	30,5 31,5 31,5 31,5 31,5 30,5	31,2 32,3 32,3 32,3 32,3 31,2
AYPC.FR76.0802	<p>Threshold profile</p>	0,81	233	353	12301400 12301421 12301424 12301430 12301431 123014808	00 RAL9016 RAL8014 RAL8017 RAL9006 A00-D6	6,5	6	39	31,4 32,8 32,8 32,8 32,8 31,4	32,1 33,6 33,6 33,6 33,6 32,1
AYPC.FR76.0803	<p>Adapter profile</p>	1,7	324	695	12301500 12301521 12301524 12301530 12301531 123015808	00 RAL9016 RAL8014 RAL8017 RAL9006 A00-D6	6,5	2	13	22,1 22,7 22,7 22,7 22,7 22,1	22,6 23,2 23,2 23,2 23,2 22,6
AYPC.FR76.0602	<p>Glass bead profile</p>	0,22	100	83,7	12301600 12301621 12301624 12301630 12301631 123016808	00 RAL9016 RAL8014 RAL8017 RAL9006 A00-D6	6,5	12	78	17,1 18,3 18,3 18,3 18,3 17,1	17,5 18,7 18,7 18,7 18,7 17,5
AYPC.FR76.0603	<p>Glass bead profile</p>	0,24	108	90,1	12301700 12301721 12301724 12301730 12301731 123017808	00 RAL9016 RAL8014 RAL8017 RAL9006 A00-D6	6,5	12	78	18,7 19,9 19,9 19,9 19,9 18,7	19,1 20,4 20,4 20,4 20,4 19,1
AYPC.FR76.0604	<p>Glass bead profile</p>	0,26	116	96,5	12301800 12301821 12301824 12301830 12301831 123018808	00 RAL9016 RAL8014 RAL8017 RAL9006 A00-D6	6,5	12	78	20,3 21,6 21,6 21,6 21,6 20,3	20,7 22,1 22,1 22,1 22,1 20,7

Article	Description Image	Weight, kg/m	Exterior perimeter, mm	Cross section area, mm ²	Code	Color	Bar length, m	Qty in pack,		Weight of pack	
								pcs	m	net, kg	gross, kg
AYPC.FR76.0605	Glass bead profile 	0,28	124	102,8	12301900 12301921 12301924 12301930 12301931 123019808	00 RAL9016 RAL8014 RAL8017 RAL9006 A00-D6	6,5	12	78	21,8 23,3 23,3 23,3 23,3 21,8	22,3 23,8 23,8 23,8 23,8 22,3
AYPC.FR76.0606	Glass bead profile 	0,29	132	109,2	12302000 12302021 12302024 12302030 12302031 123020808	00 RAL9016 RAL8014 RAL8017 RAL9006 A00-D6	6,5	12	78	22,6 24,2 24,2 24,2 24,2 22,6	23,1 24,8 24,8 24,8 24,8 23,1
AYPC.FR76.0607	Glass bead profile 	0,31	140	115,6	12302100 12302121 12302124 12302130 12302131 123021808	00 RAL9016 RAL8014 RAL8017 RAL9006 A00-D6	6,5	12	78	24,2 25,8 25,8 25,8 25,8 24,2	24,7 26,4 26,4 26,4 26,4 24,7
AYPC.FR76.0608	Glass bead profile 	0,33	148	121,8	12300400 12300421 12300424 12300430 12300431 123004808	00 RAL9016 RAL8014 RAL8017 RAL9006 A00-D6	6,5	12	78	25,7 26,3 26,3 26,3 26,3 25,7	26,2 26,8 26,8 26,8 26,8 26,2
AYPC.FR76.0609	Glass bead profile 	0,35	156	128,5	12302200 12302221 12302224 12302230 12302231 123022808	00 RAL9016 RAL8014 RAL8017 RAL9006 A00-D6	6,5	12	78	27,3 29,1 29,1 29,1 29,1 27,3	27,9 29,8 29,8 29,8 29,8 27,9
AYPC.FR76.0610	Glass bead profile 	0,36	164	135	12302600 12302621 12302624 12302630 12302631 123026808	00 RAL9016 RAL8014 RAL8017 RAL9006 A00-D6	6,5	12	78	28,1 29,9 29,9 29,9 29,9 28,1	28,7 30,7 30,7 30,7 30,7 28,7
AYPC.FR76.0611	Glass bead profile 	0,38	172	141	12302700 12302721 12302724 12302730 12302731 123027808	00 RAL9016 RAL8014 RAL8017 RAL9006 A00-D6	6,5	12	78	29,6 31,6 31,6 31,6 31,6 29,6	30,2 32,3 32,3 32,3 32,3 30,2
AYPC.FR76.0613	Door adjoining profile 	0,19	80	69,7	12302300 12302321 12302324 12302330 12302331 123023808	00 RAL9016 RAL8014 RAL8017 RAL9006 A00-D6	6,5	16	104	19,8 21 21 21 21 19,8	20,2 21,5 21,5 21,5 21,5 20,2

Article	Description Image	Weight, kg/m	Exterior perimeter, mm	Cross section area, mm ²	Code	Color	Bar length, m	Qty in pack,		Weight of pack	
								pcs	m	net, kg	gross, kg
AYPC.FR76.0614	Door adjoining profile 	0,15	57	55,1	12302400 12302421 12302424 12302430 12302431 123024808	00 RAL9016 RAL8014 RAL8017 RAL9006 A00-D6	6,5	20	130	19,5 20,7 20,7 20,7 19,5	19,9 21,2 21,2 21,2 19,9
AYPC.FR76.0701	Transom fixing element profile 	0,567	148	210	12302500	00	3,25	12	39	22,1	22,6
AYPC.C48.0702	Corner crimping profile 	2,103	322,9	776,1	10403600	00	3,25	2	6,5	13,6	13,6
AYPC.C48.0703	Corner crimping profile 	2,822	347,0	1045,3	10403700	00	3,25	2	6,5	18,3	18,3
AYPC.C48.0704	Corner crimping profile 	3,816	387,5	1413,6	10403800	00	3,25	2	6,5	24,8	24,8



ALT FR76
FIRE RESISTANT
DOORS WITH DOUBLE
THERMAL BREAK

ACCESSORIES

03



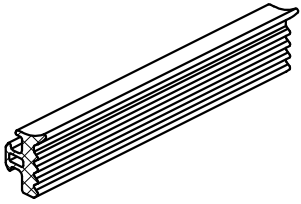
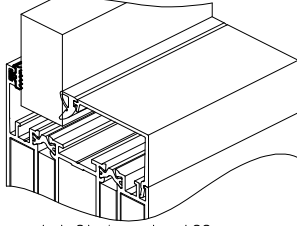
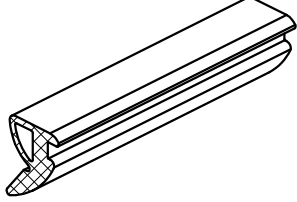
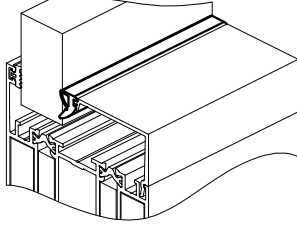
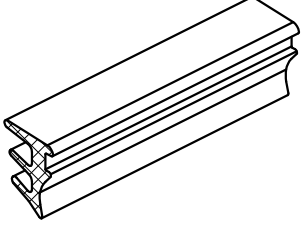
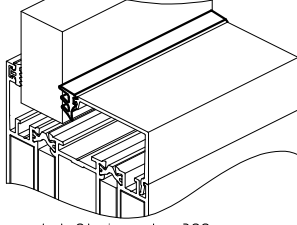
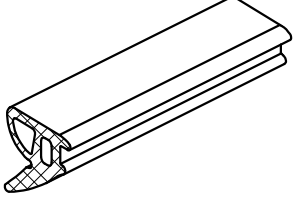
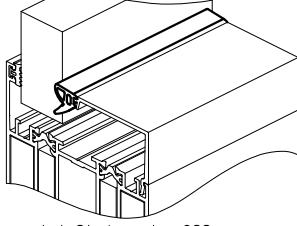
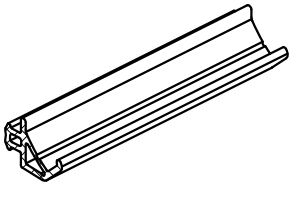
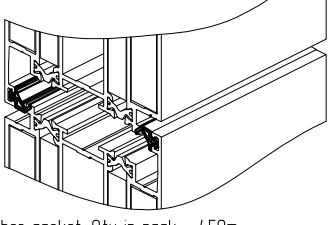
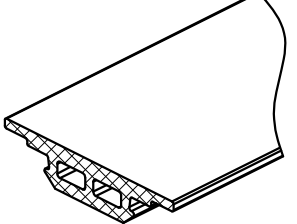
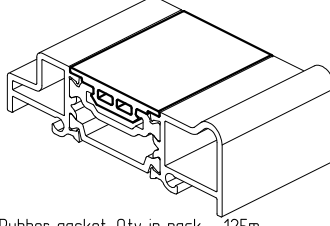
Image	Code	Article	Application
	10415900	FRK29-01	 Rubber gasket. Qty in pack - 400m
	11216300	FRK36	 Rubber gasket. Qty in pack - 250m
	10415600	FRK39	 Rubber gasket. Qty in pack - 300m
	11216600	FRK67	 Rubber gasket. Qty in pack - 200m
	12320000	FRK148	 Rubber gasket. Qty in pack - 450m
	12320100	FRK155	 Rubber gasket. Qty in pack - 125m

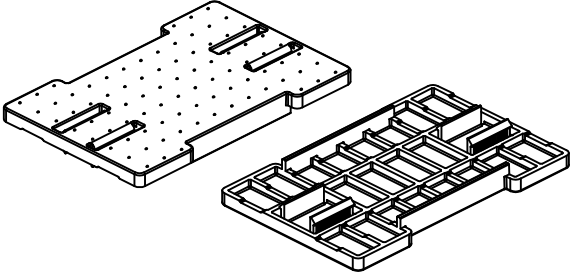
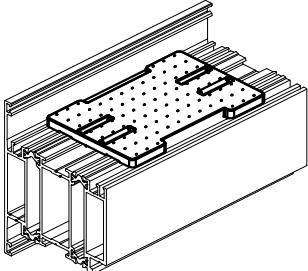
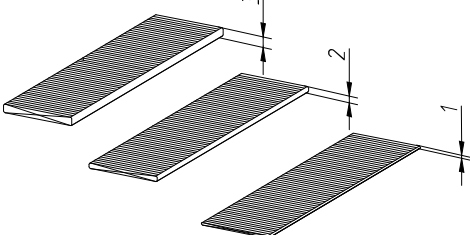
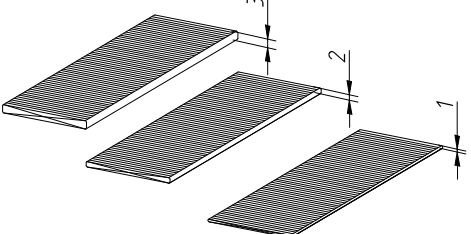
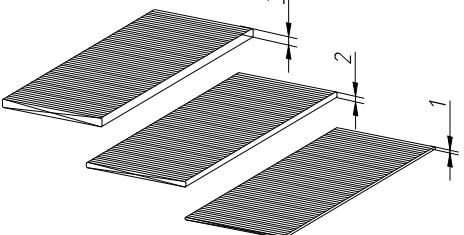
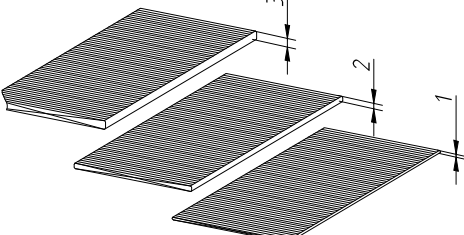
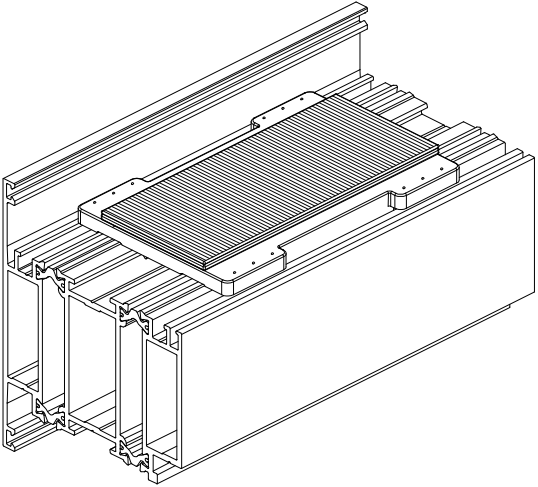
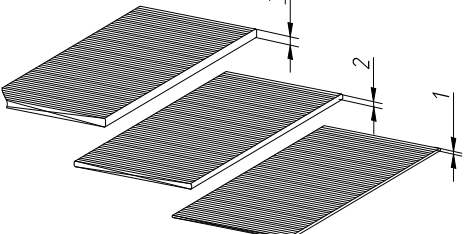
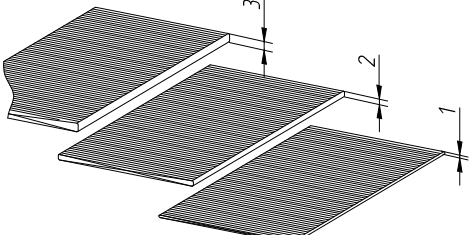
Image	Code	Article	Application
	12356000	AYPC.FR76.0901	 Bearing support. Qty in pack - 90 pcs
	10414600 10414700 10414800	100x26x1 100x26x2 100x26x3	
	11213400 11213500 11213600	100x32x1 100x32x2 100x32x3	
	11213700 11213800 11213900	100x38x1 100x38x2 100x38x3	
	11218100 11218200 11218300	100x44x1 100x44x2 100x44x3	
	11218400 11218500 11218600	100x50x1 100x50x2 100x50x3	
	11219400 11219500 11219600	100x62x1 100x62x2 100x62x3	Leveling support. Qty in pack - 1000 pcs

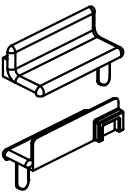
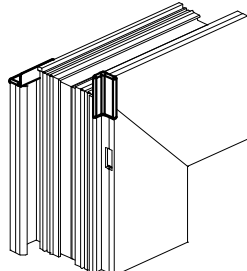
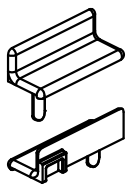
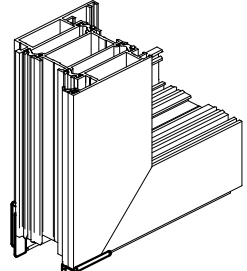
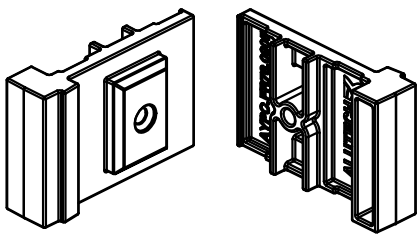
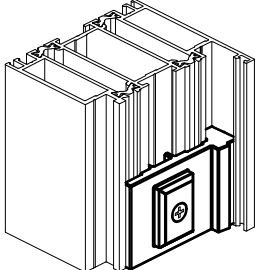
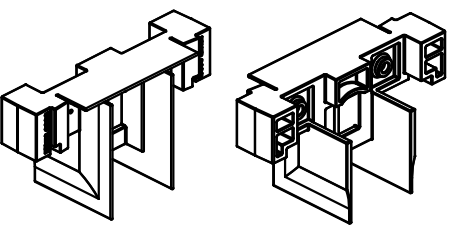
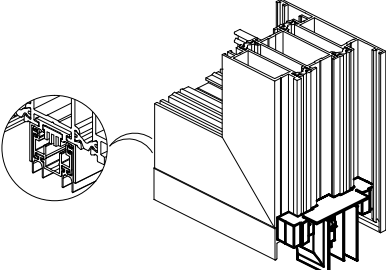
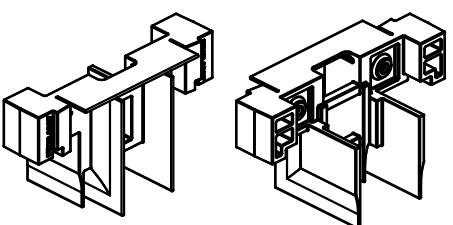
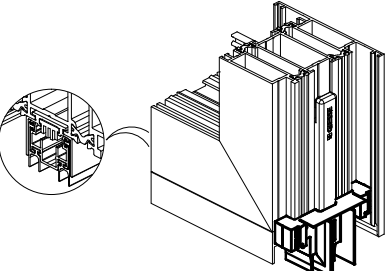
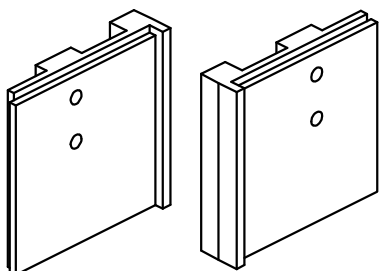
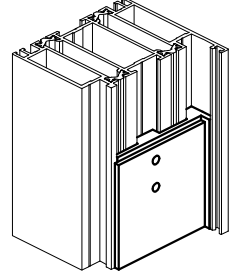
Image	Code	Article	Application
	12356200	AYPC.FR76.0903	 End ledge plug. Qty in pack - 30 pcs
	12356300	AYPC.FR76.0904	 End ledge plug. Qty in pack - 30 pcs
	12356400	AYPC.FR76.0905	 Automatic threshold plug. Qty in pack - 30 pcs
	12356500	AYPC.FR76.0906	 Automatic threshold collar. Qty in pack - 30 pcs
	12356600	AYPC.FR76.0907	 Threshold collar. Qty in pack - 30 pcs
	12356700 12356800	AYPC.FR76.0908 AYPC.FR76.0908-01	 Threshold plug. Qty in pack - 50 pcs

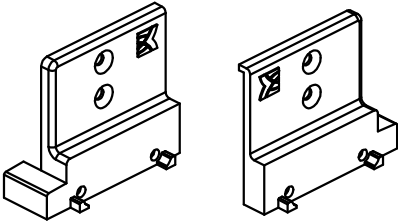
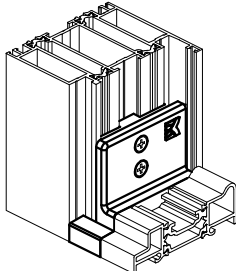
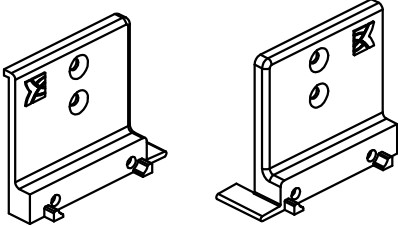
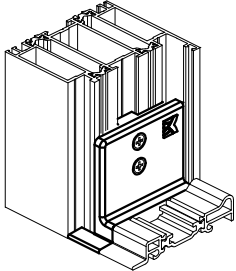
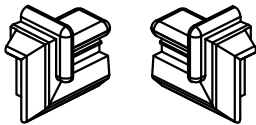
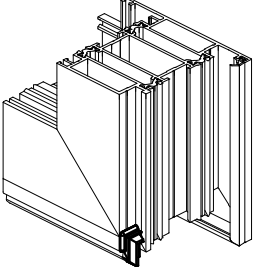
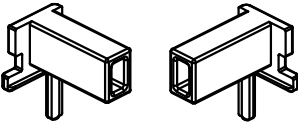
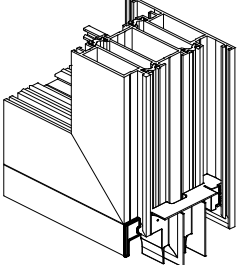
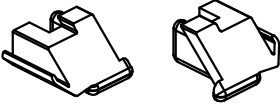
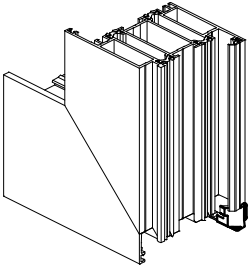
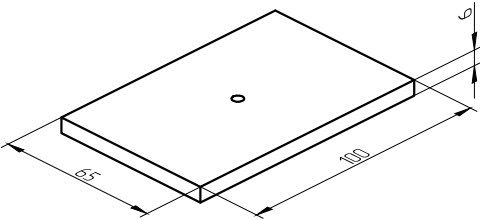
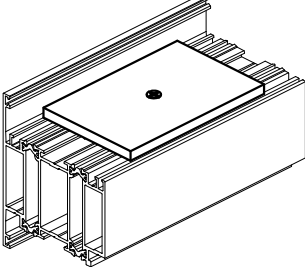
Image	Code	Article	Application
	12356900 12357000	AYPC.FR76.0909 AYPC.FR76.0909-01	 Threshold plug. Qty in pack - 50 pcs
	12357100 12357200	AYPC.FR76.0910 AYPC.FR76.0910-01	 Threshold plug. Qty in pack - 50 pcs
	12357400 12357500	AYPC.FR76.0912 AYPC.FR76.0912-01	 Door adjoining profile collar. Qty in pack - 50 pcs
	12357600 12357700	AYPC.FR76.0913 AYPC.FR76.0913-01	 Plug for adjoining profile. Qty in pack - 50 pcs
	12357800 12357900	AYPC.FR76.0914 AYPC.FR76.0914-01	 Door adjoining profile collar. Qty in pack - 50 pcs
	12356100	AYPC.FR76.0902	 Wooden support. Qty in pack - 38 pcs

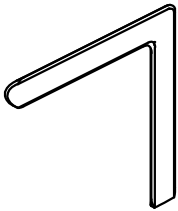
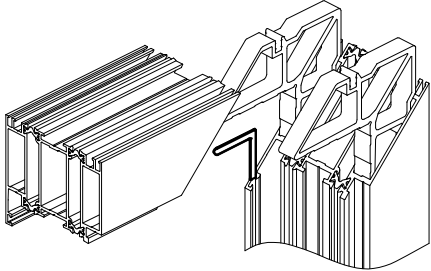
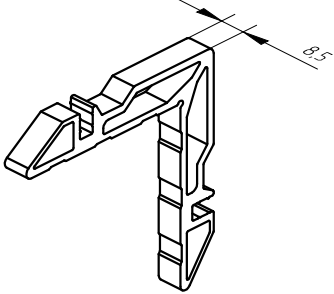
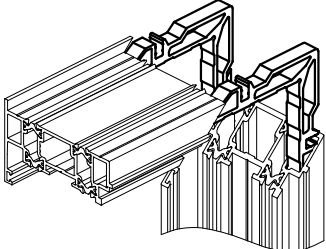
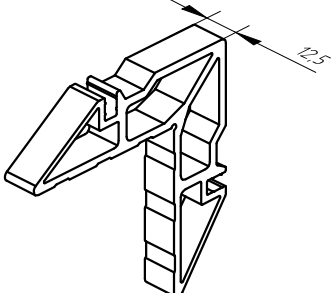
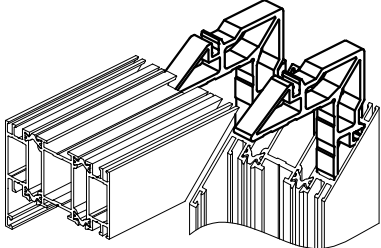
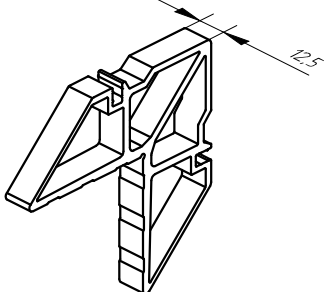
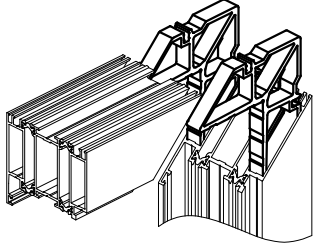
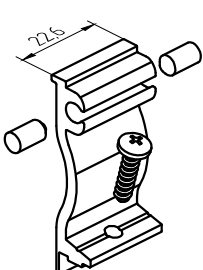
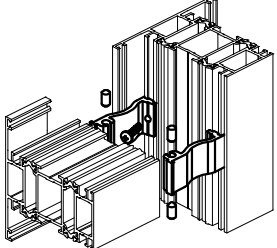
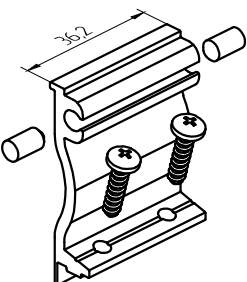
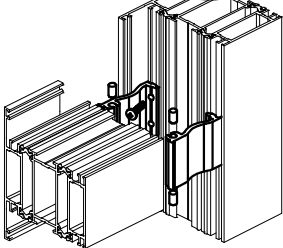
Image	Code	Article	Application
	12354300	0715	 Clamping corner. Qty in pack - 500 pcs
	12354700	AYPC.FR76.0952	 Clamping corner. Qty in pack - 250 pcs Reference profile - AYPC.C48.0702
	12354800	AYPC.FR76.0953	 Clamping corner. Qty in pack - 130 pcs Reference profile - AYPC.C48.0703
	12355000	AYPC.FR76.0955	 Clamping corner. Qty in pack - 140 pcs Reference profile - AYPC.C48.0704
	12354400	AYPC.FR76.0951	 Transom fixing element. Qty in pack - 130 pcs Reference profile - AYPC.FR76.0701
	12354500	AYPC.FR76.0951-01	 Transom fixing element. Qty in pack - 80 pcs Reference profile - AYPC.FR76.0701

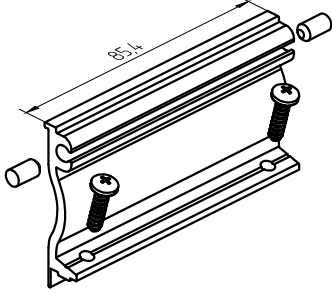
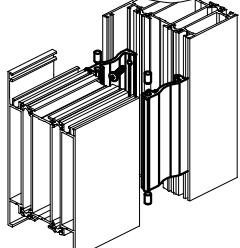
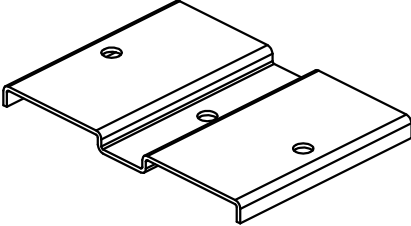
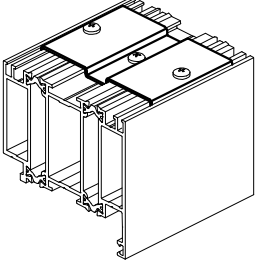
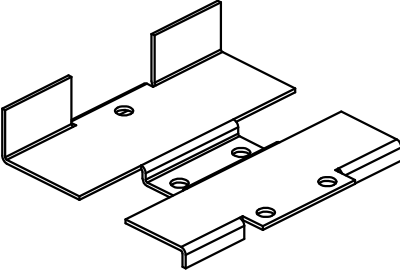
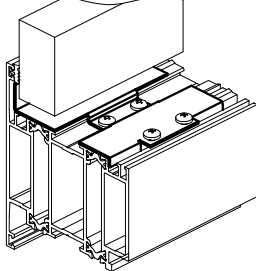
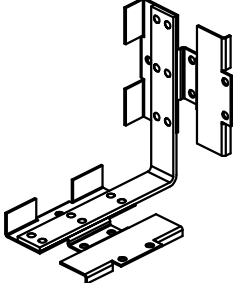
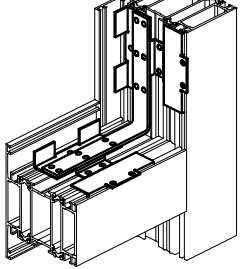
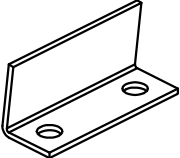
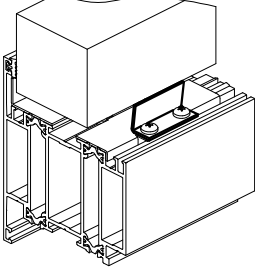
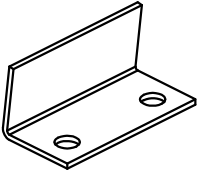
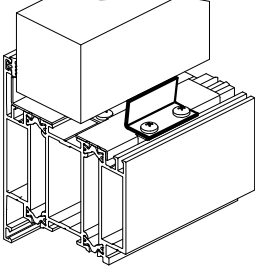
Image	Code	Article	Application
	12354600	AYPC.FR76.0951-02	 Transom fixing element. Qty in pack - 35 pcs Reference profile - AYPC.FR76.0701
	12350000	AYPC.FR76.1001	 Steel holder. Qty in pack - 100 pcs
	12350100	AYPC.FR76.1002	 Steel holder. Qty in pack - 50 pcs
	12350200	AYPC.FR76.1003	 Corner connector. Qty in pack - 50 pcs
	12350300	AYPC.FR76.1004	 Steel holder for infill unit 4-8mm. Qty in pack - 50pcs
	12350400	AYPC.FR76.1005	 Steel holder for infill unit 4-4-6mm. Qty in pack - 50pcs

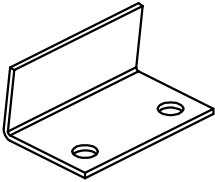
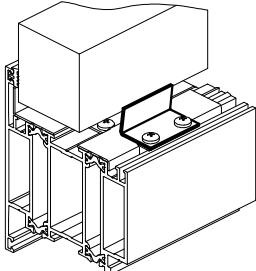
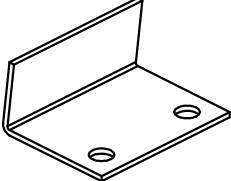
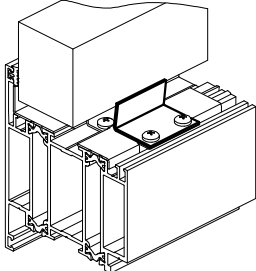
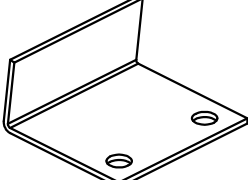
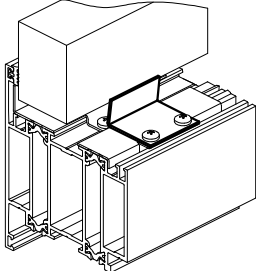
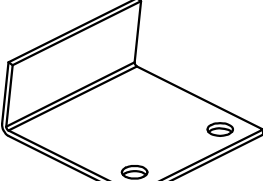
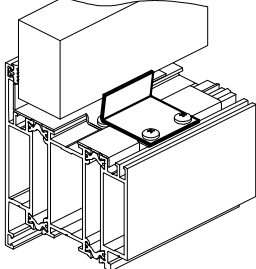

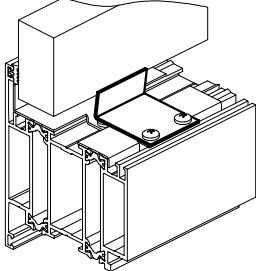
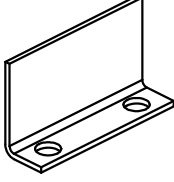
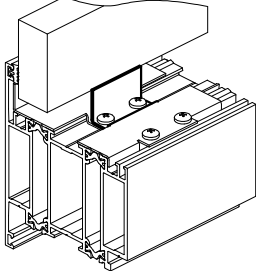
Image	Code	Article	Application
	12350500	AYPC.FR76.1006	 Steel holder for infill unit 40-42mm. Qty in pack - 50pcs
	12350600	AYPC.FR76.1007	 Steel holder for infill unit 36-38mm. Qty in pack - 50pcs
	12350700	AYPC.FR76.1008	 Steel holder for infill unit 32-34mm. Qty in pack - 50pcs
	12350800	AYPC.FR76.1009	 Steel holder for infill unit 28-30mm. Qty in pack - 50pcs
	12350900	AYPC.FR76.1010	 Steel holder for infill unit 24-26mm. Qty in pack - 50pcs
	10950200	AYPC.W72.1003	 Steel holder for infill unit 20-22mm. Qty in pack - 100pcs

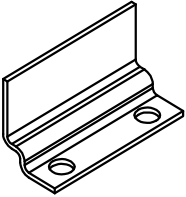
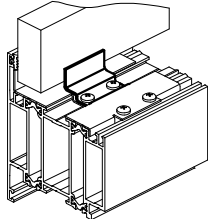
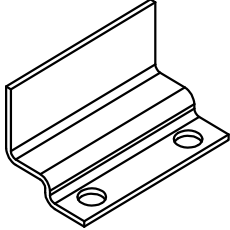
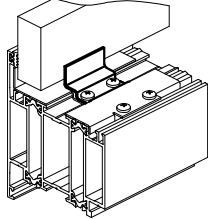
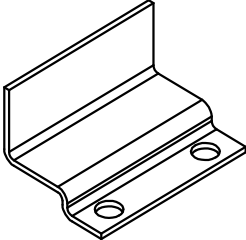
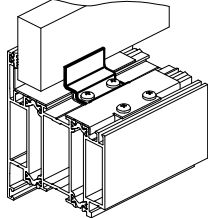
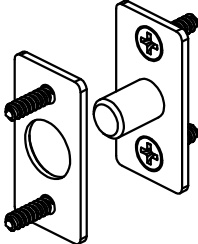
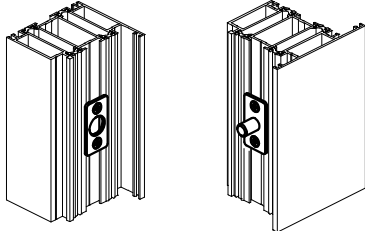
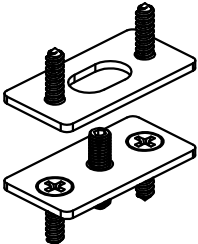
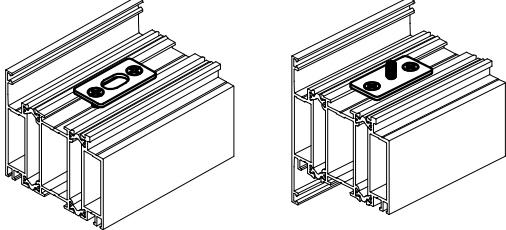
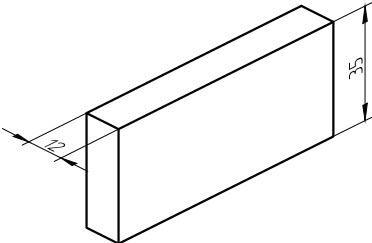
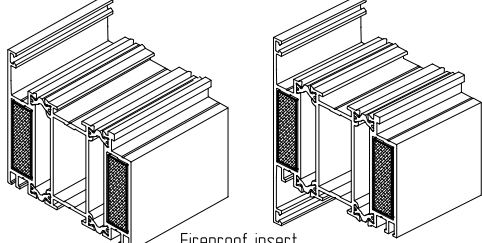
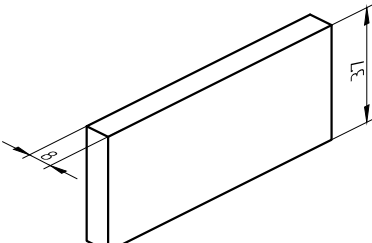
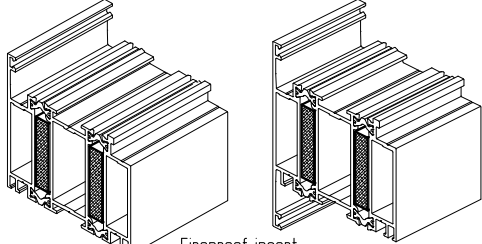
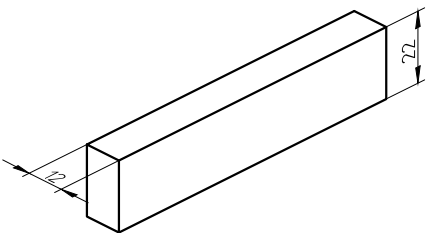
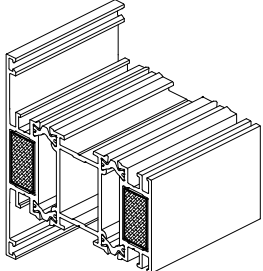
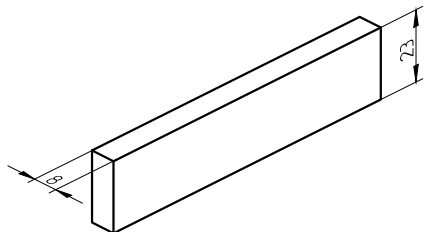
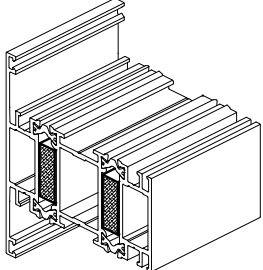
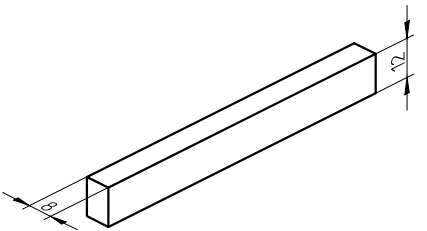
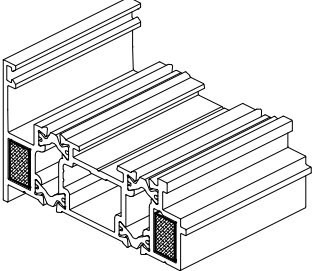
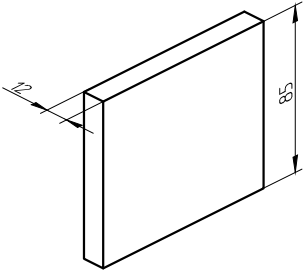
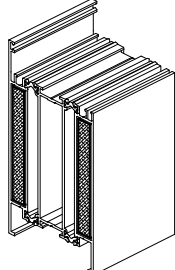
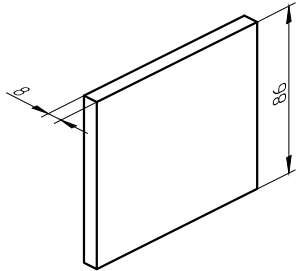
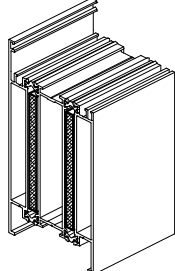
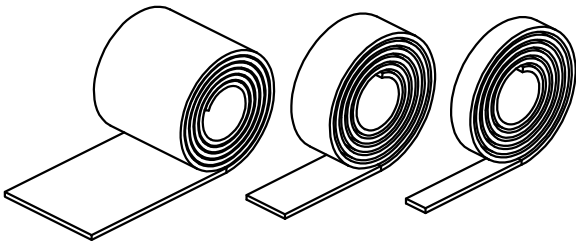
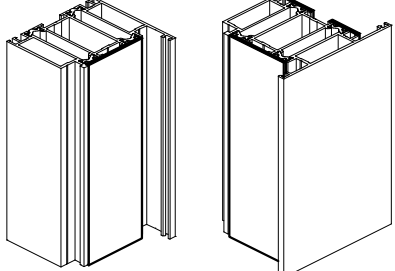
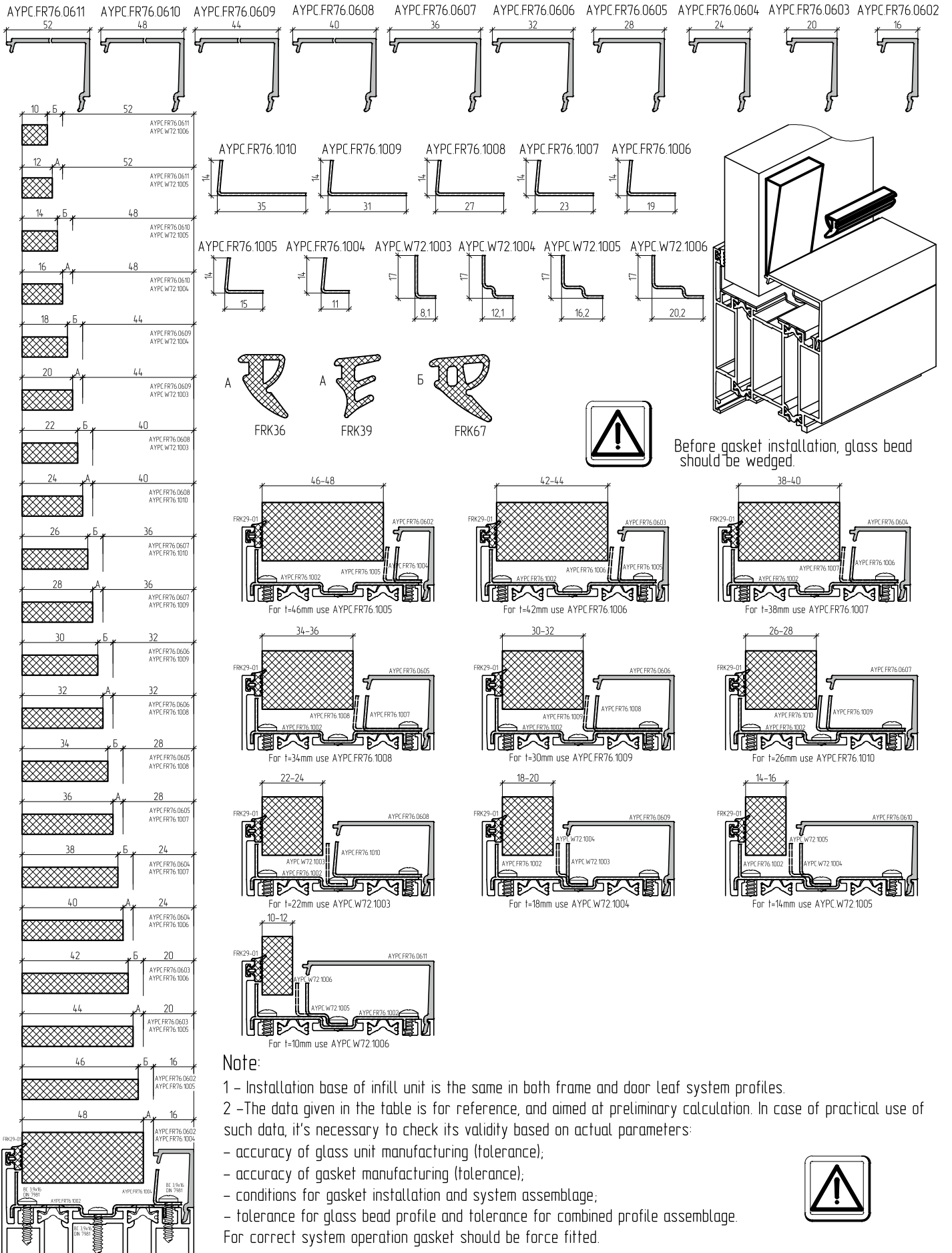
Image	Code	Article	Application
	10950300	AYPC.W72.1004	 Steel holder for infill unit 16-18mm. Qty in pack - 100pcs
	10950400	AYPC.W72.1005	 Steel holder for infill unit 12-14mm. Qty in pack - 100pcs
	10950500	AYPC.W72.1006	 Steel holder for infill unit 10mm. Qty in pack - 100pcs
	10952400	AYPC.W72.1009	 Kit of fireproof cover. Qty in pack - 30 units
	10952500	AYPC.W72.1010	 Kit of upper fireproof cover. Qty in pack - 30 units.
	12352000	AYPC.FR76.2001	 Fireproof insert
	12352100	AYPC.FR76.2002	 Fireproof insert

Image	Code	Article	Application
	12352200	AYPC.FR76.2003	 Fireproof insert.
	12352300	AYPC.FR76.2004	 Fireproof insert.
	12352400	AYPC.FR76.2005	 Fireproof insert.
	12352500	AYPC.FR76.2006	 Fireproof insert.
	12352600	AYPC.FR76.2007	 Fireproof insert.
	10952700 10952900 10954900	LTU10x2 LTU20x2 LTU50x2	 Thermal seating tape.



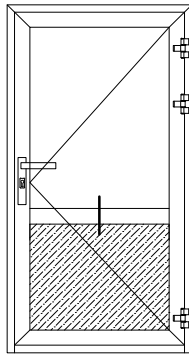
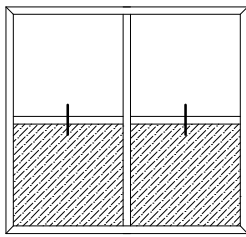
ALT FR76
FIRE RESISTANT
DOORS WITH DOUBLE
THERMAL BREAK

TABLE OF GLAZING

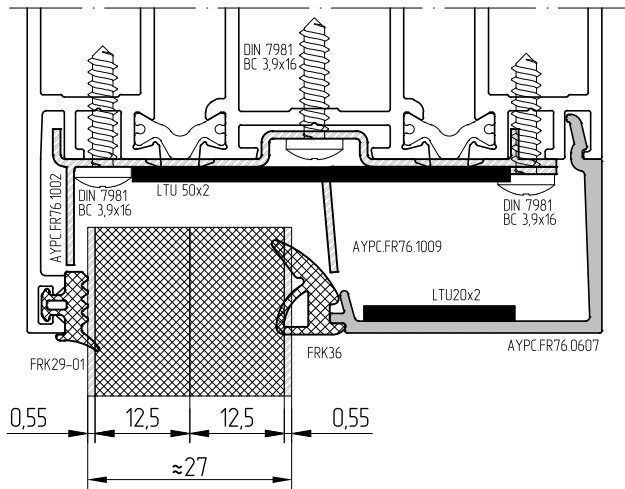


Note:

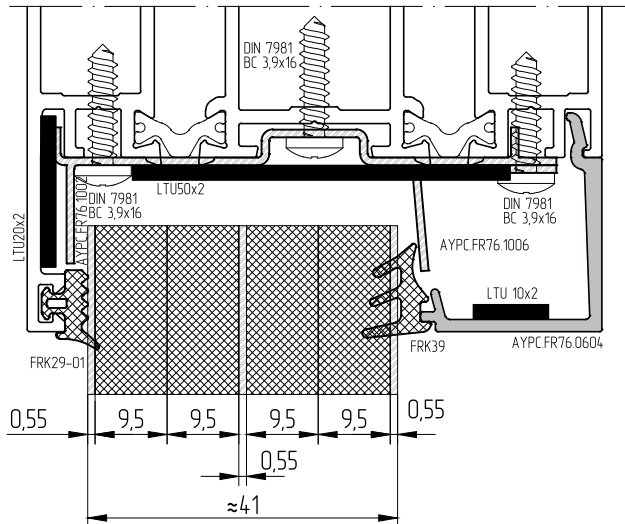
- 1 - Installation base of infill unit is the same in both frame and door leaf system profiles.
 - 2 - The data given in the table is for reference, and aimed at preliminary calculation. In case of practical use of such data, it's necessary to check its validity based on actual parameters:
 - accuracy of glass unit manufacturing (tolerance);
 - accuracy of gasket manufacturing (tolerance);
 - conditions for gasket installation and system assemblage;
 - tolerance for glass bead profile and tolerance for combined profile assemblage.
- For correct system operation gasket should be force fitted.



EW30

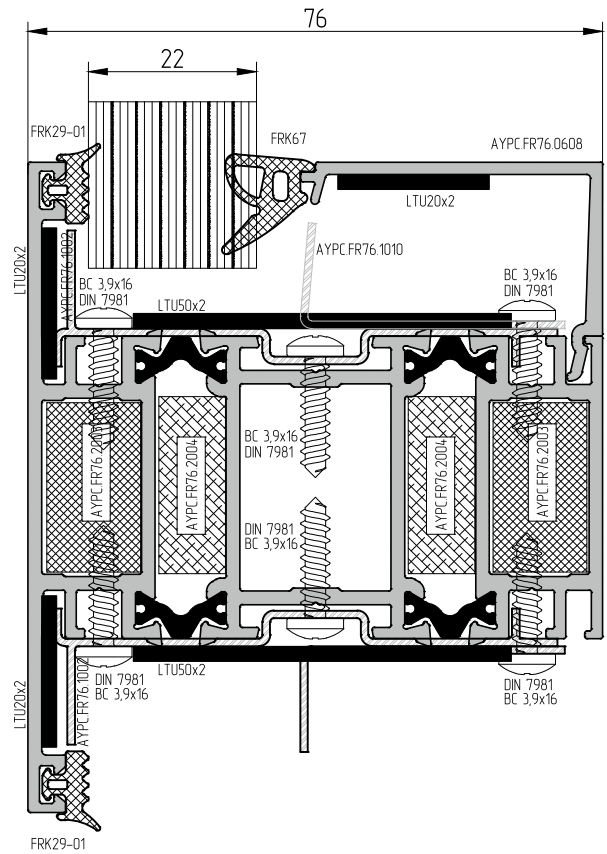


EW45

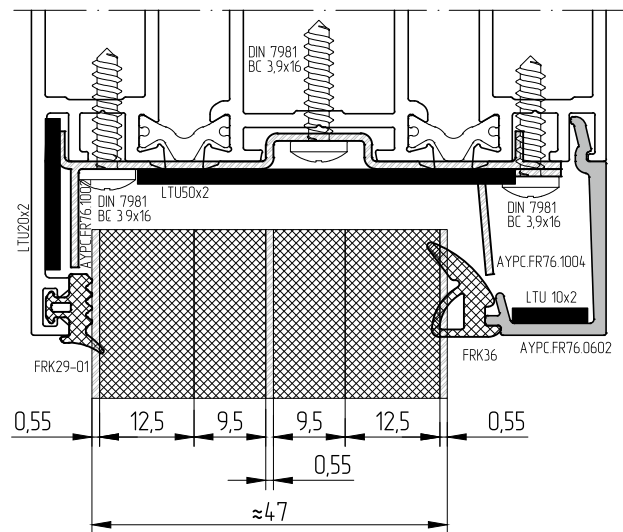


- 1 - zinc coated sheet of 0,55 mm.
- 2 - moisture resistant gypsum board MRGB of 9,5 mm.
- 3 - moisture resistant (fire-resistant) gypsum board MRGB (FRGB) of 12,5 mm.

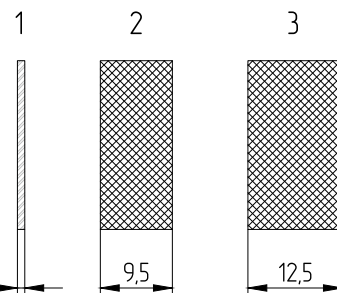
76



EW60



Sandwich panel structure



- 1. Depending on the requirements to fireproof system, different types of fireproof infill unit of various manufacturers are used
- 2. Joint solutions depending on fire-resistance rating are shown in chapter 05 - Cross sections and joint solutions.

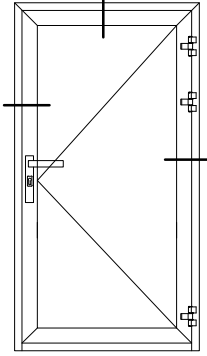


ALT FR76

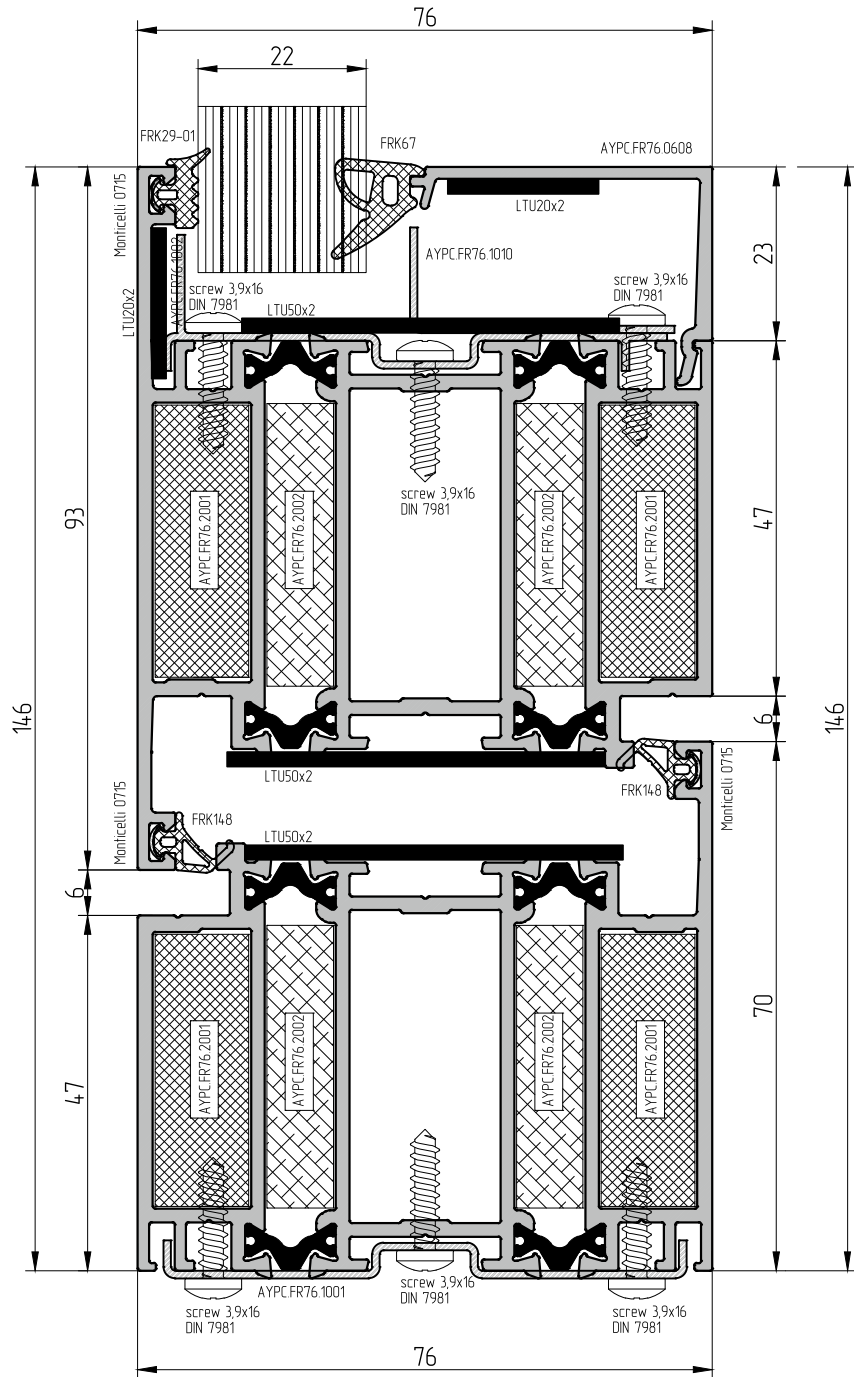
FIRE RESISTANT
DOORS WITH DOUBLE
THERMAL BREAK

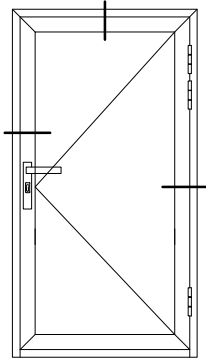
CROSS SECTIONS AND JOINT SOLUTIONS

05

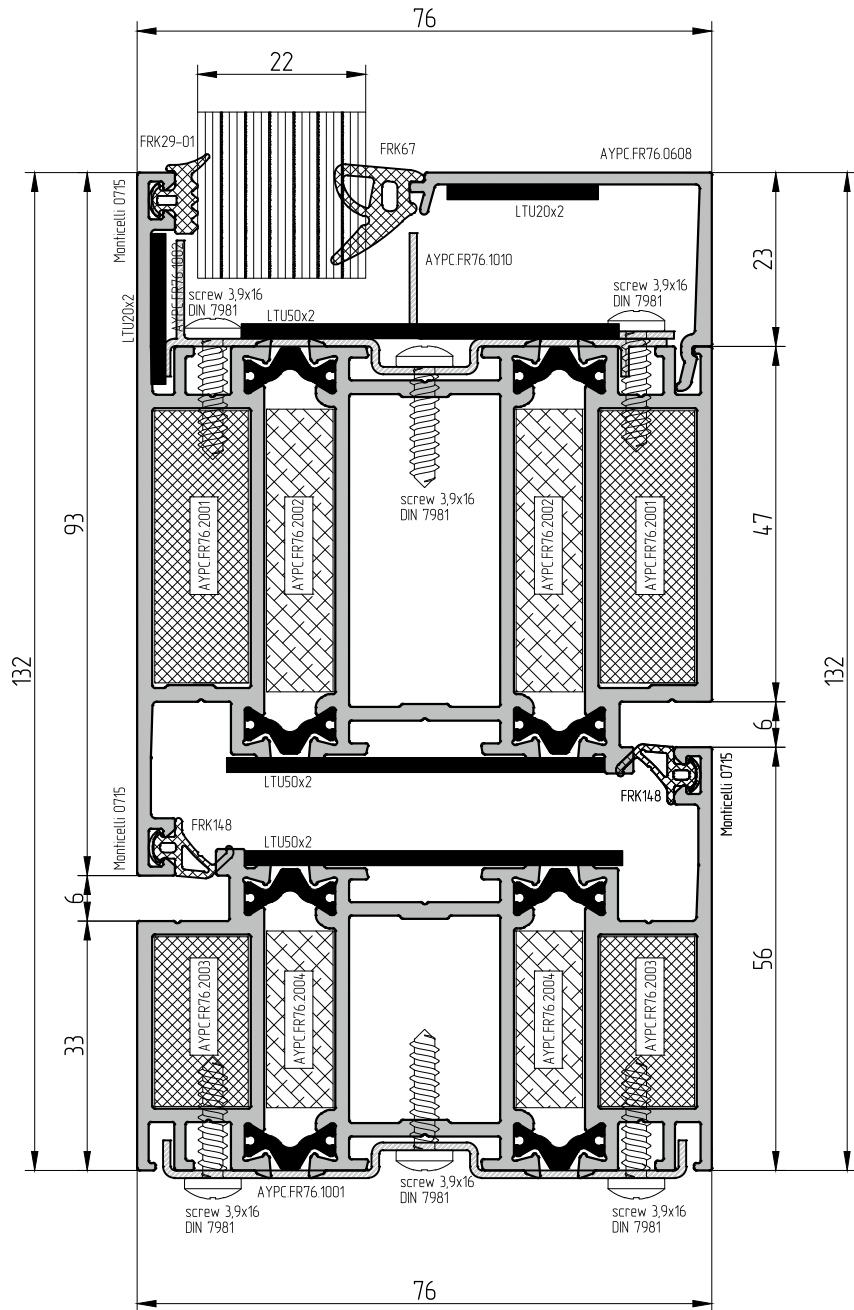


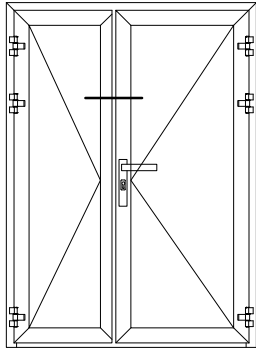
AYPC.FR76.0101 + AYPC.FR76.0201



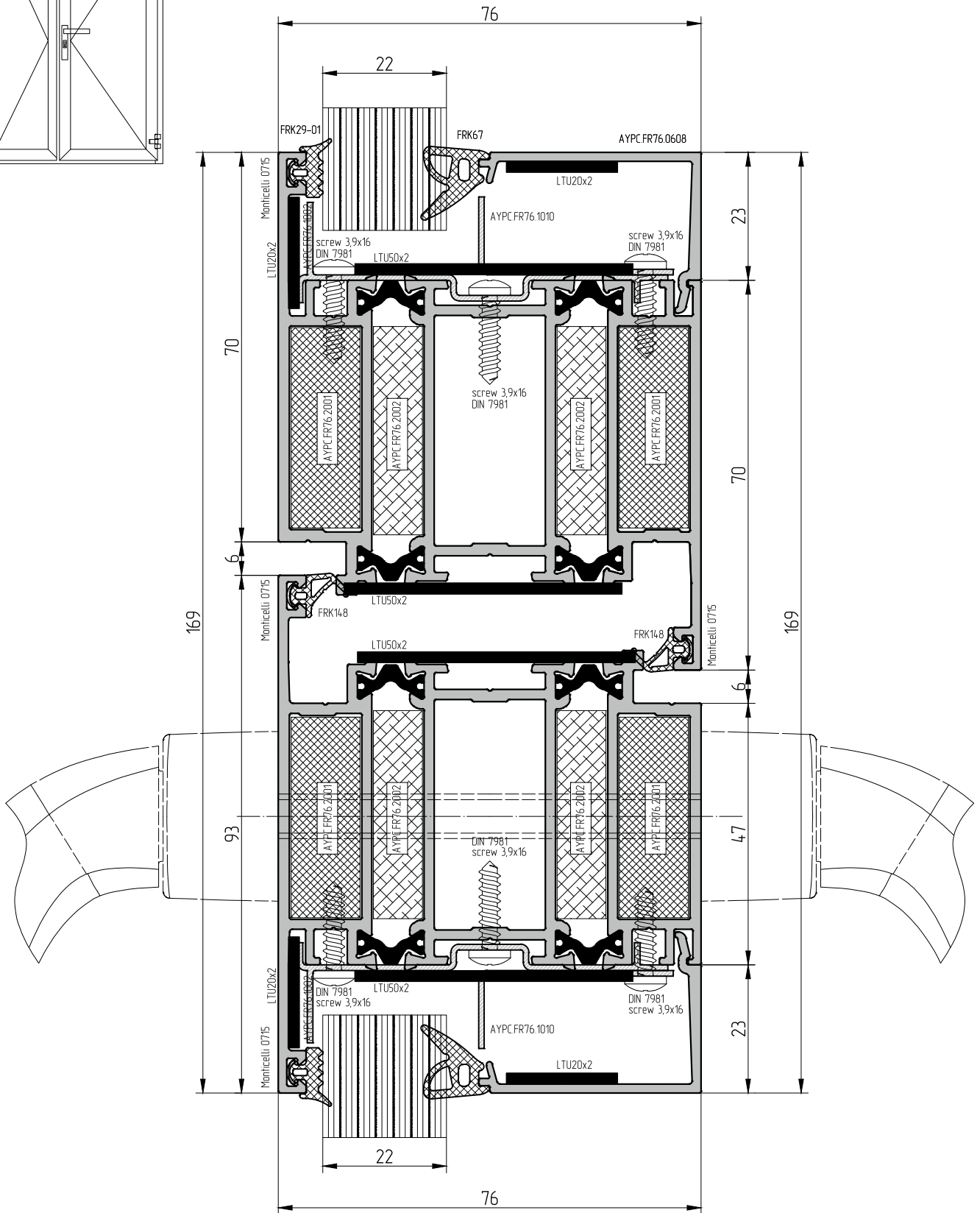


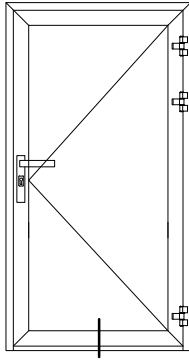
AYPC.FR76.0102 + AYPC.FR76.0201



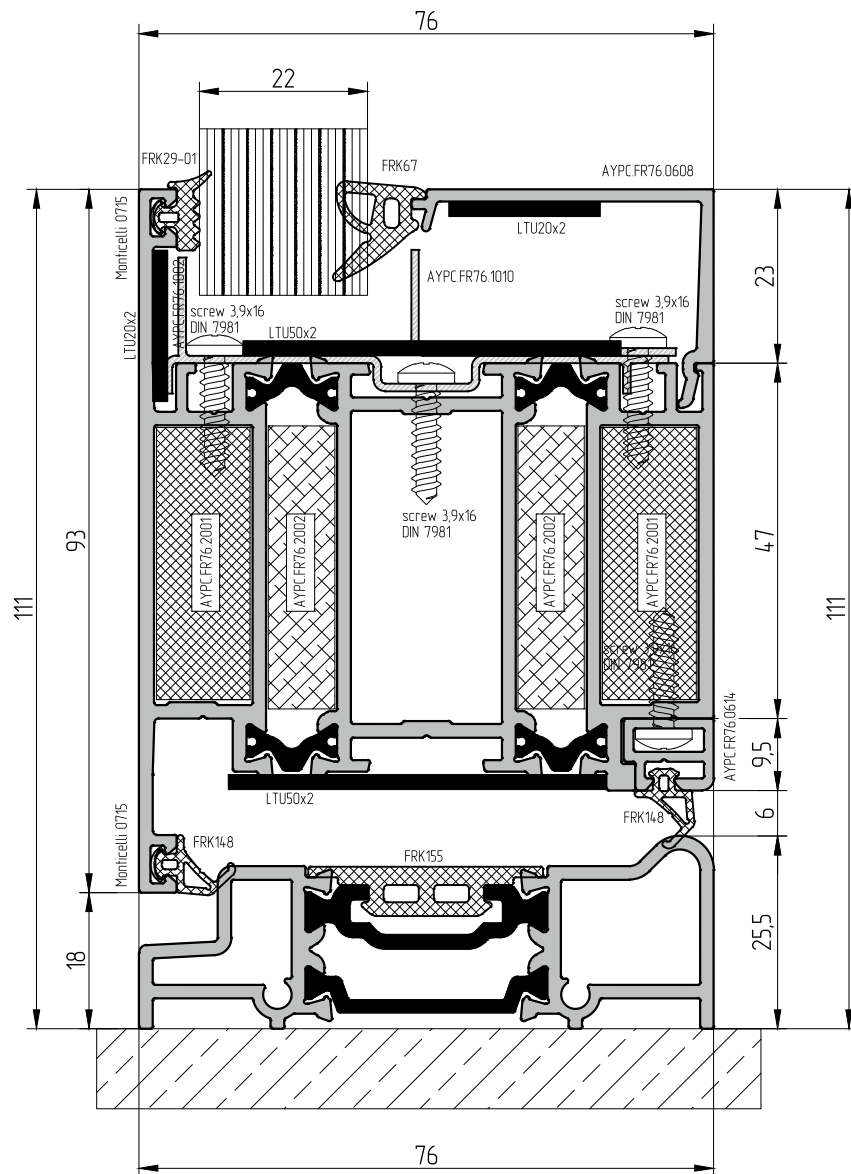


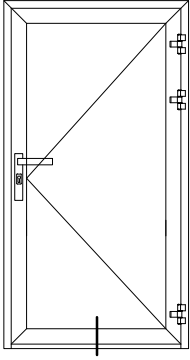
AYPC.FR76.0201 + AYPC.FR76.0202



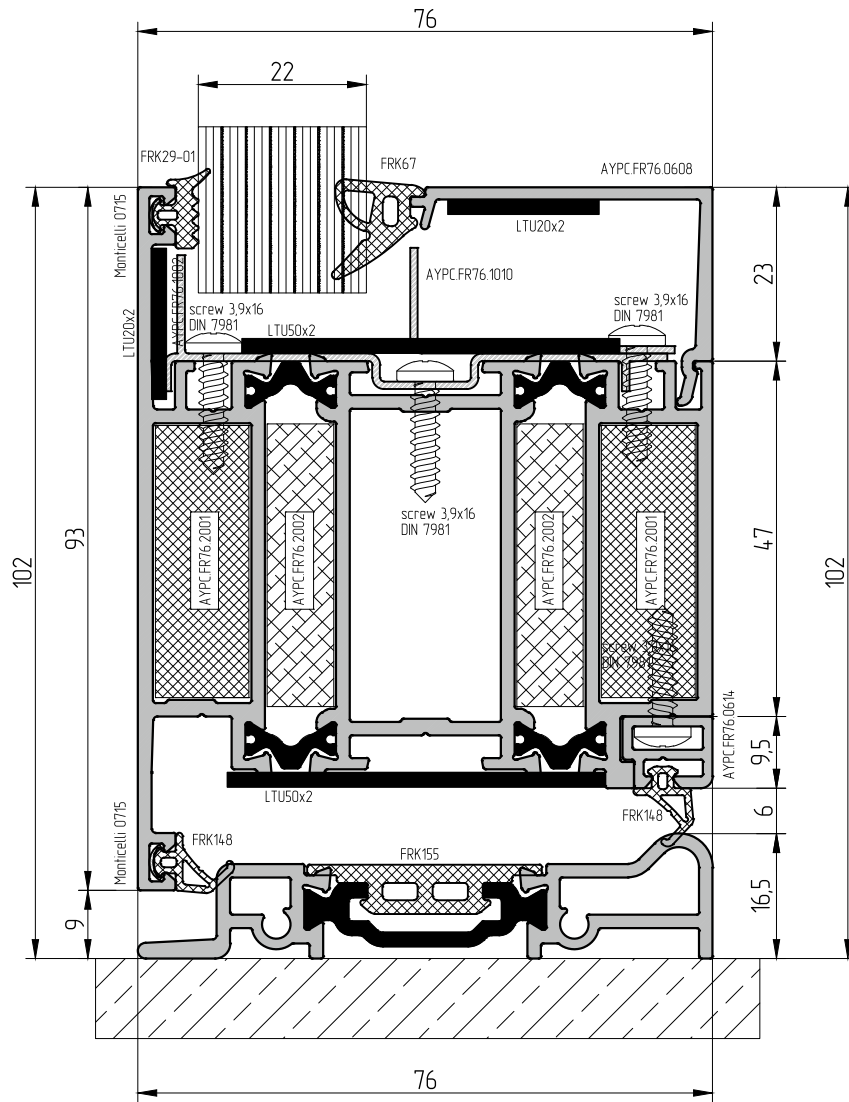


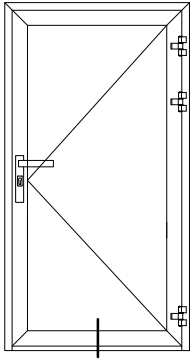
AYPC.FR76.0201 + AYPC.FR76.0801 + AYPC.FR76.0614



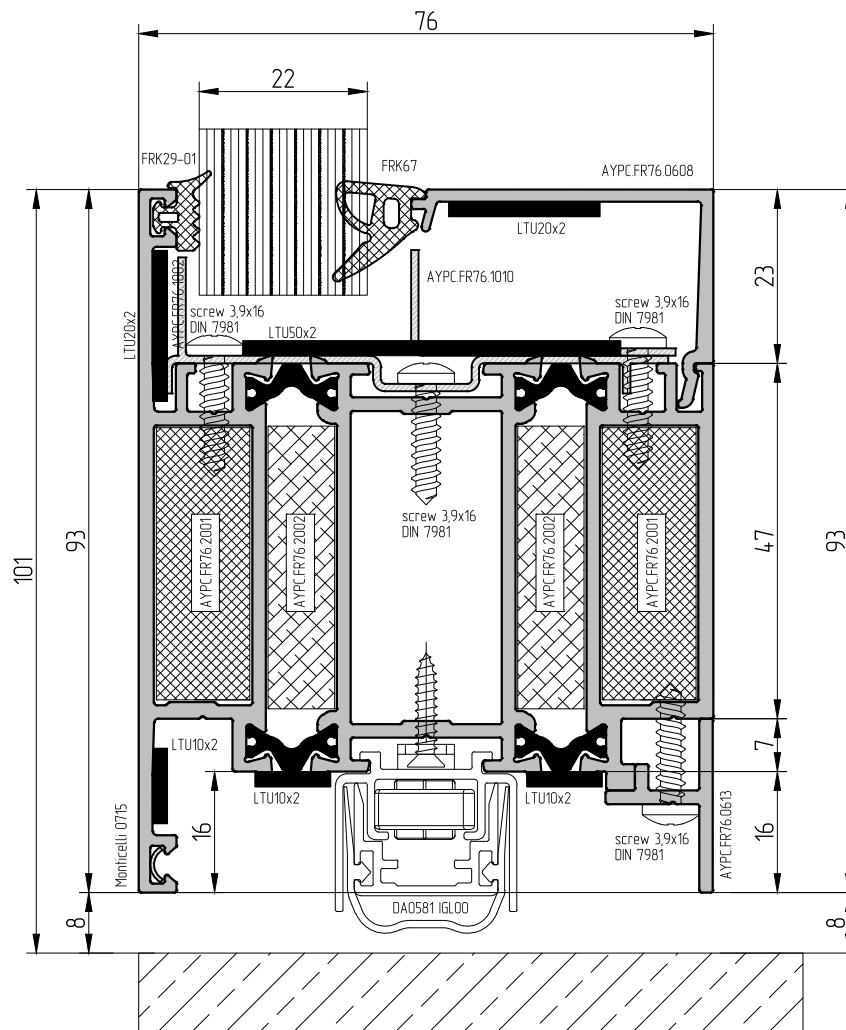


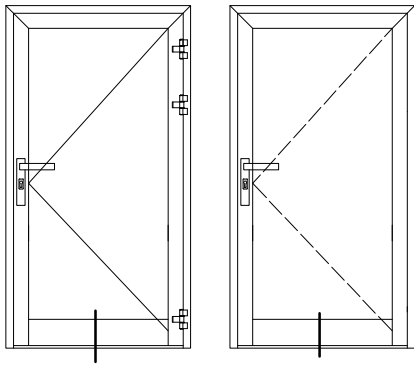
AYPC.FR76.0201 + AYPC.FR76.0802 + AYPC.FR76.0614



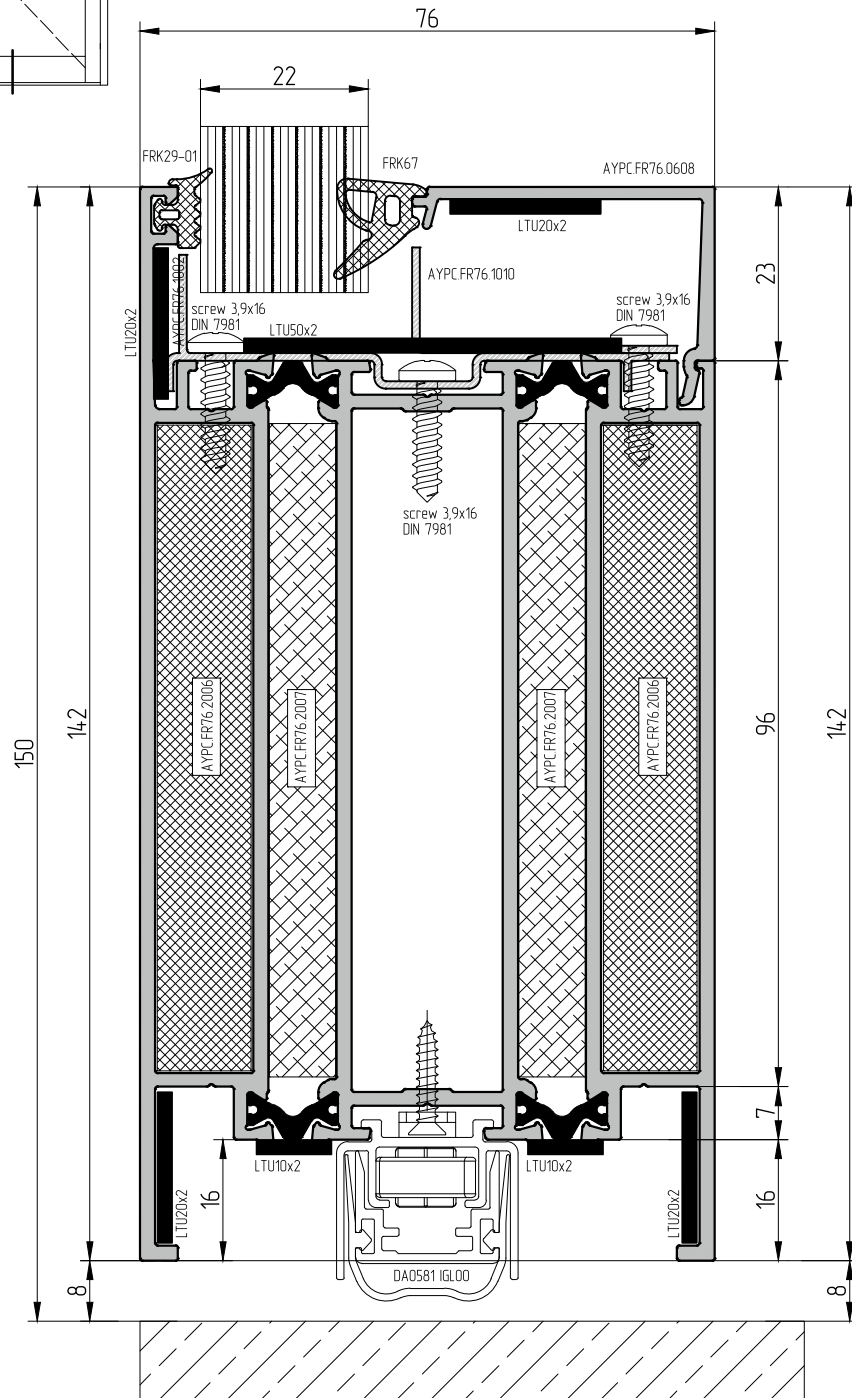


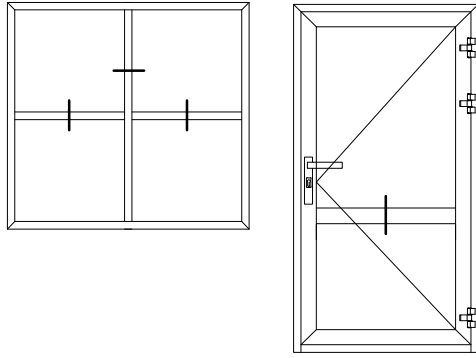
AYPC.FR76.0201 + AYPC.FR76.0613 + DA0581 IGL00



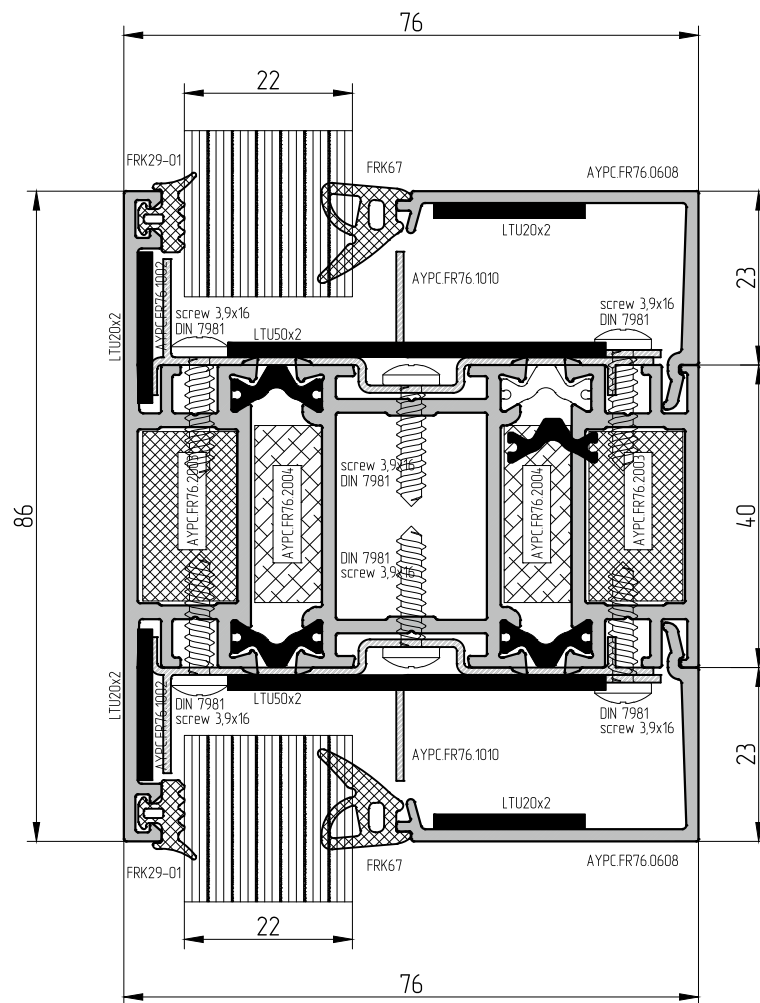


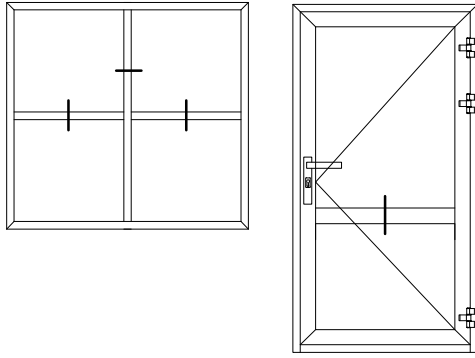
AYPC.FR76.0105 + DA0581 IGL00



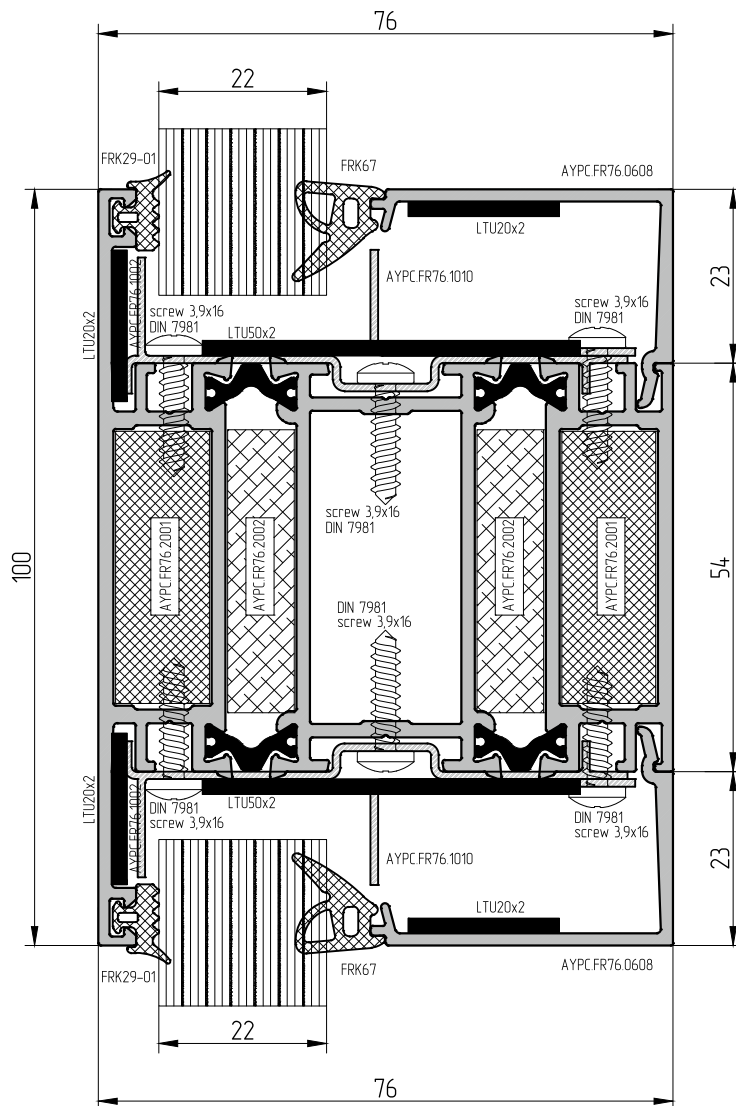


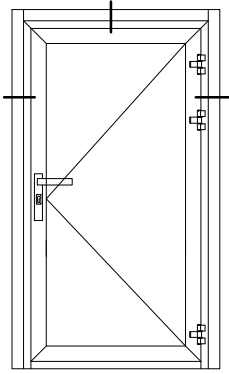
AYPC.FR76.0301



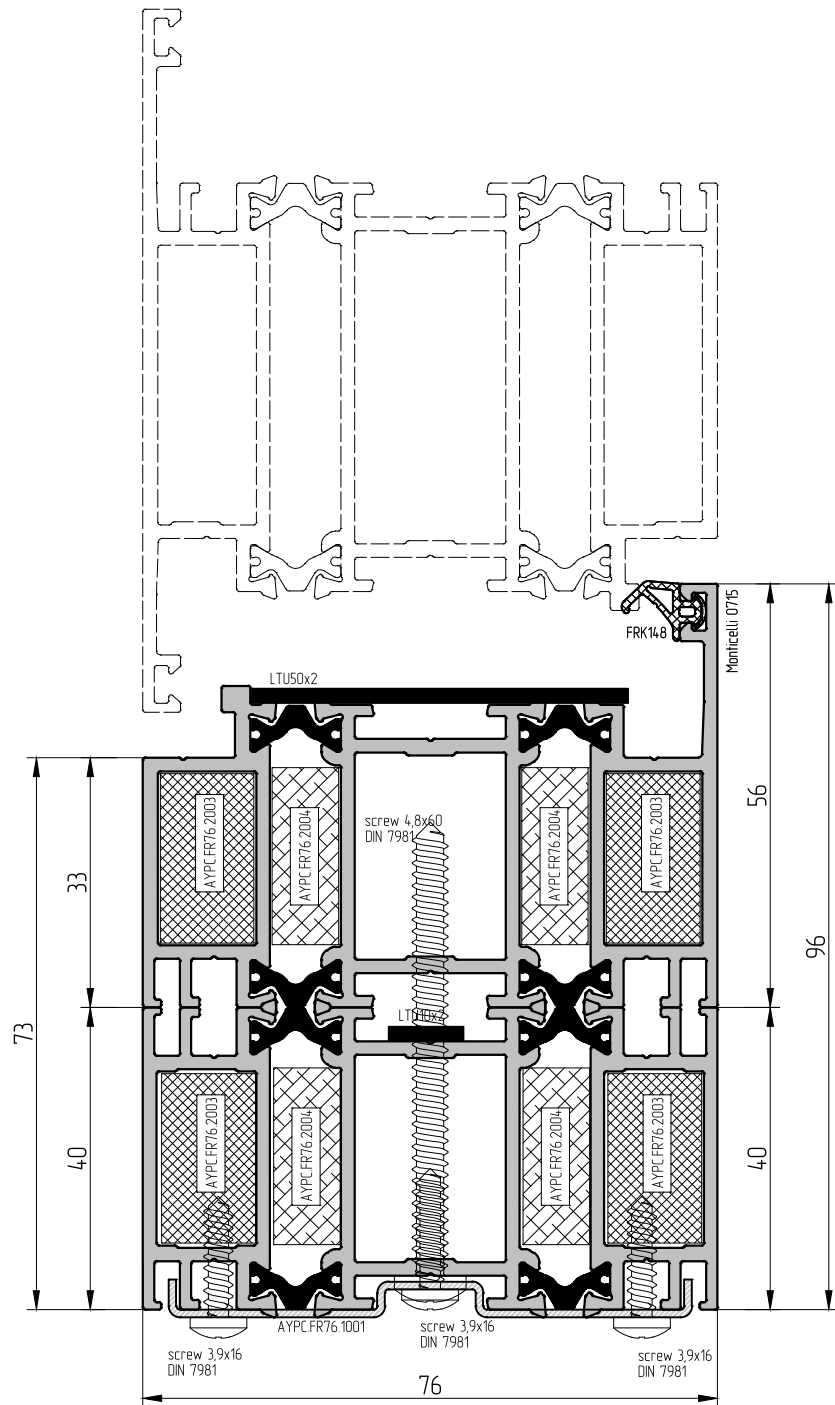


AYPC.FR76.0302

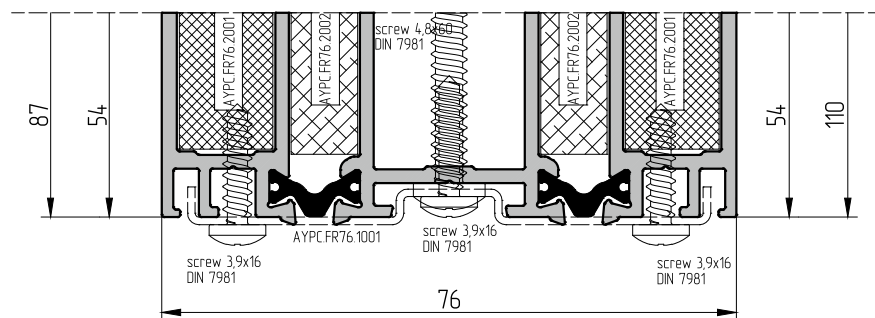


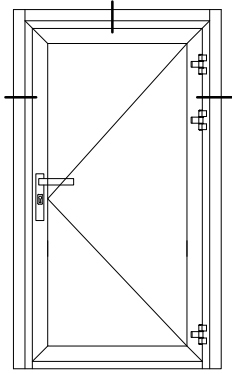


AYPC.FR76.0102 + AYPC.FR76.0120

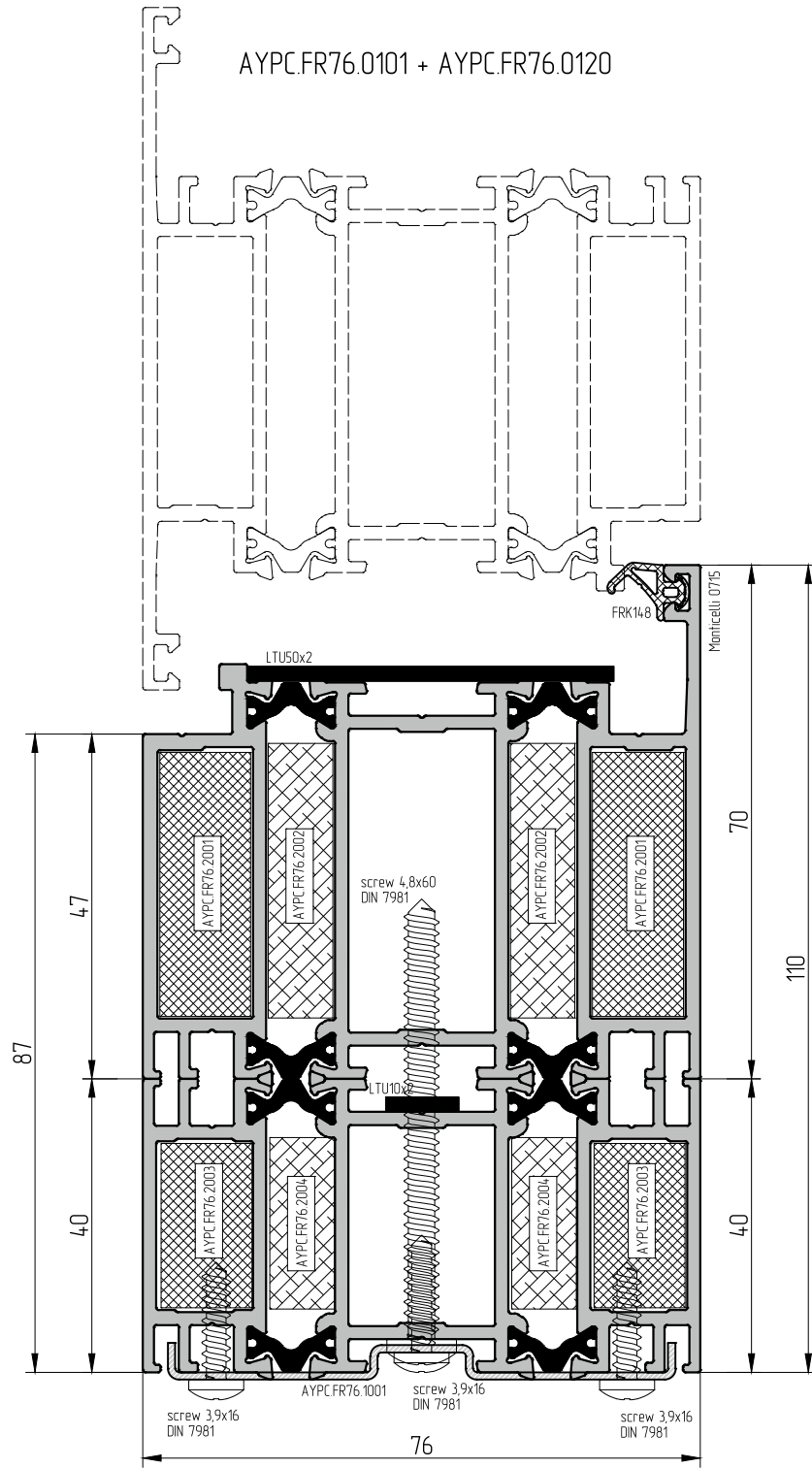


AYPC.FR76.0121

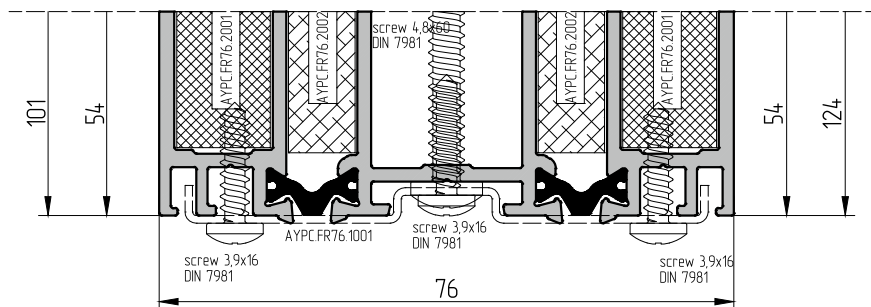


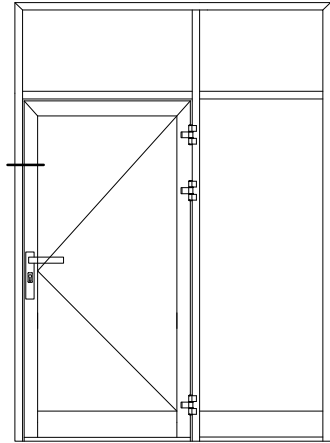


AYPC.FR76.0101 + AYPC.FR76.0120

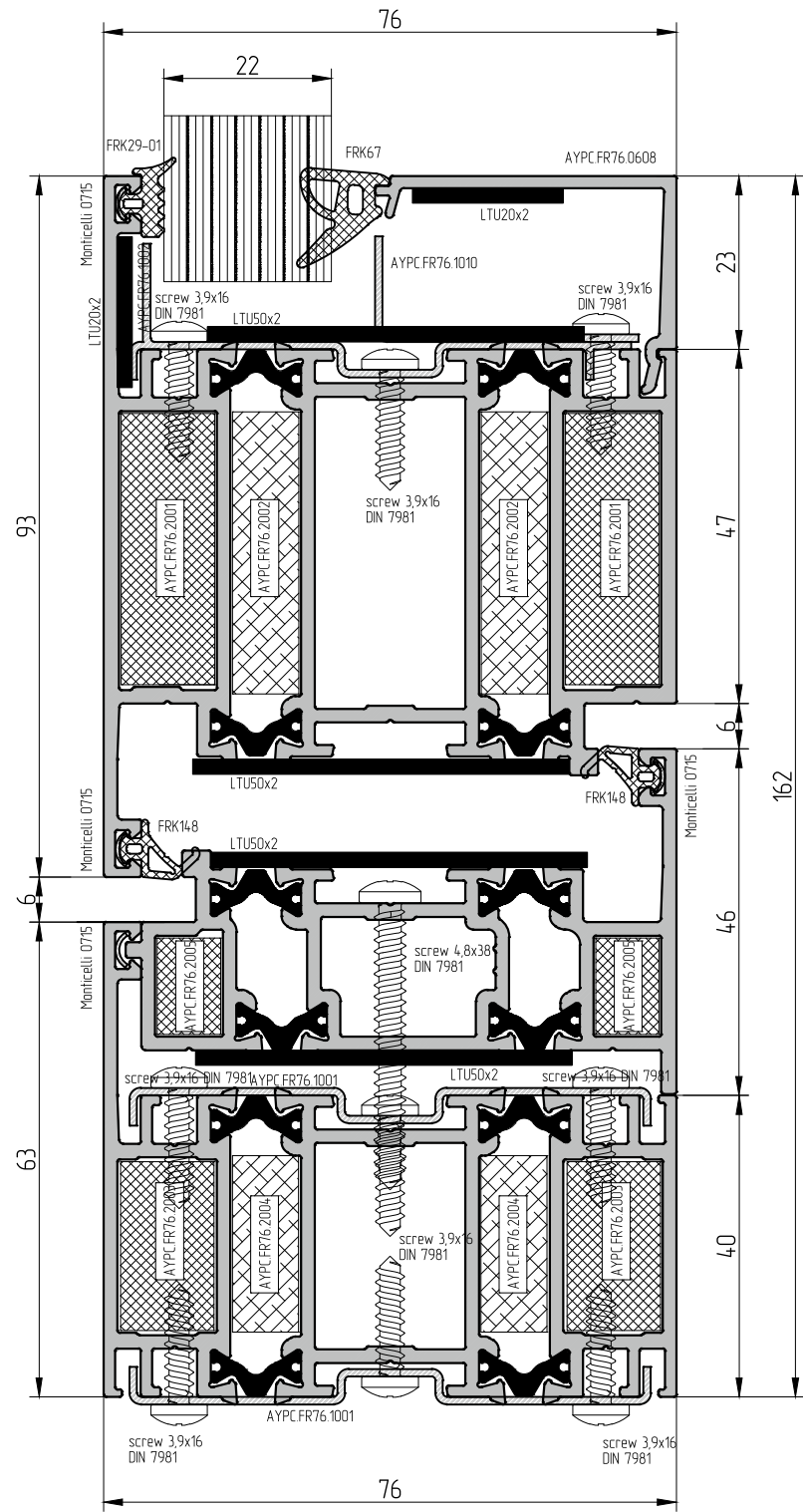


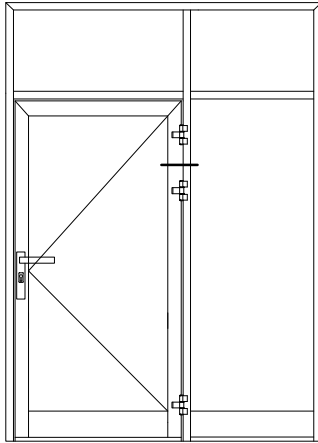
AYPC.FR76.0121



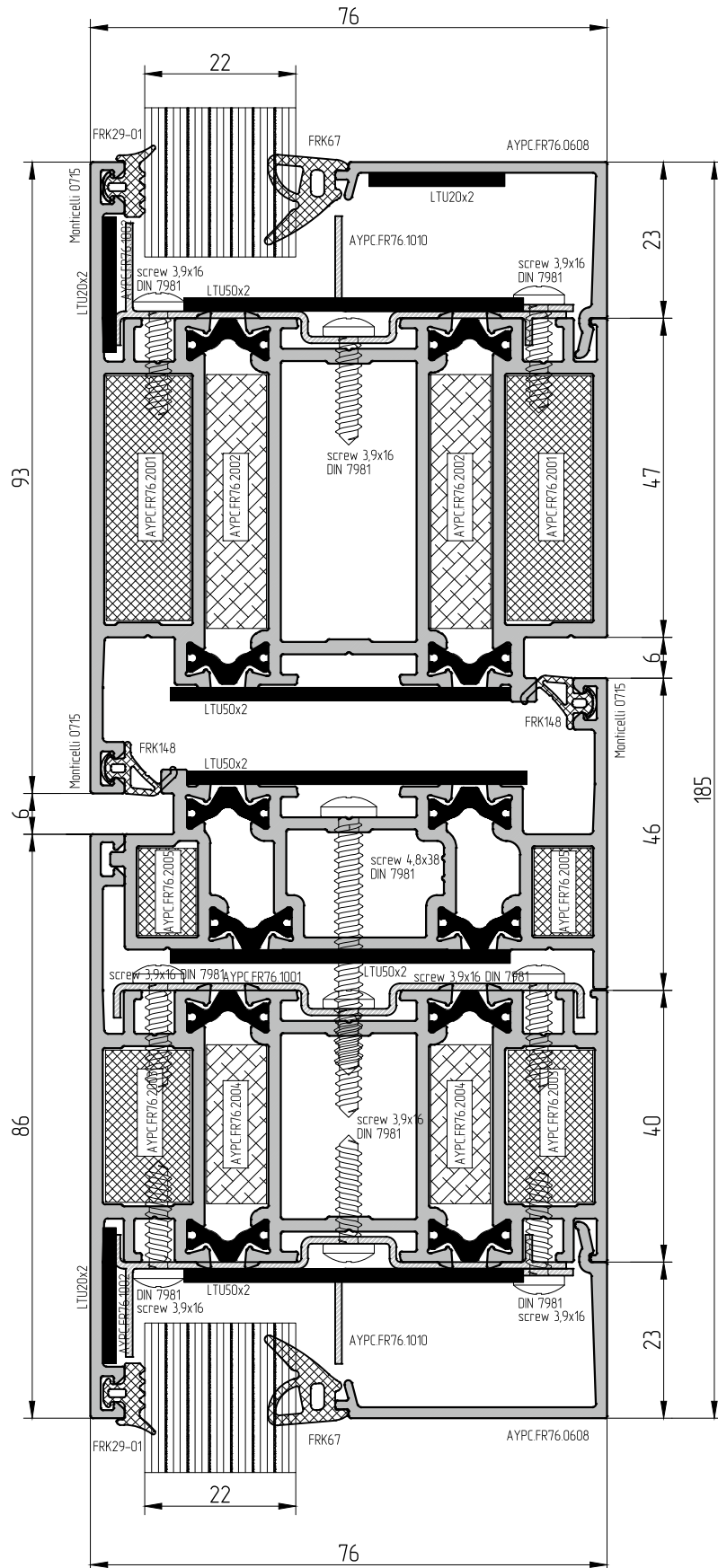


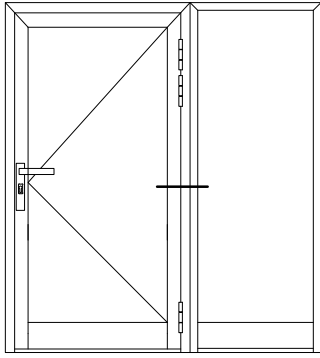
AYPC.FR76.0103 + AYPC.FR76.0803 + AYPC.FR76.0201



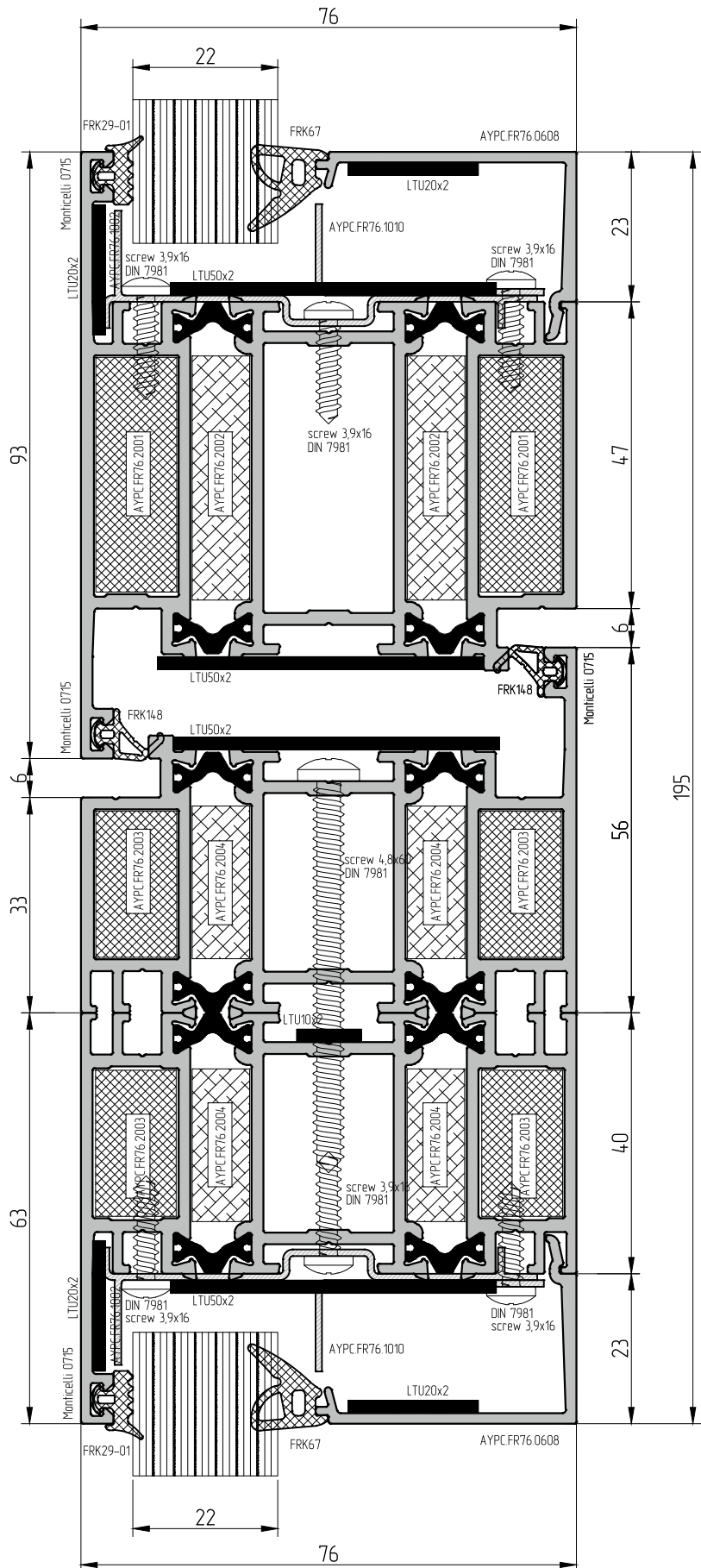


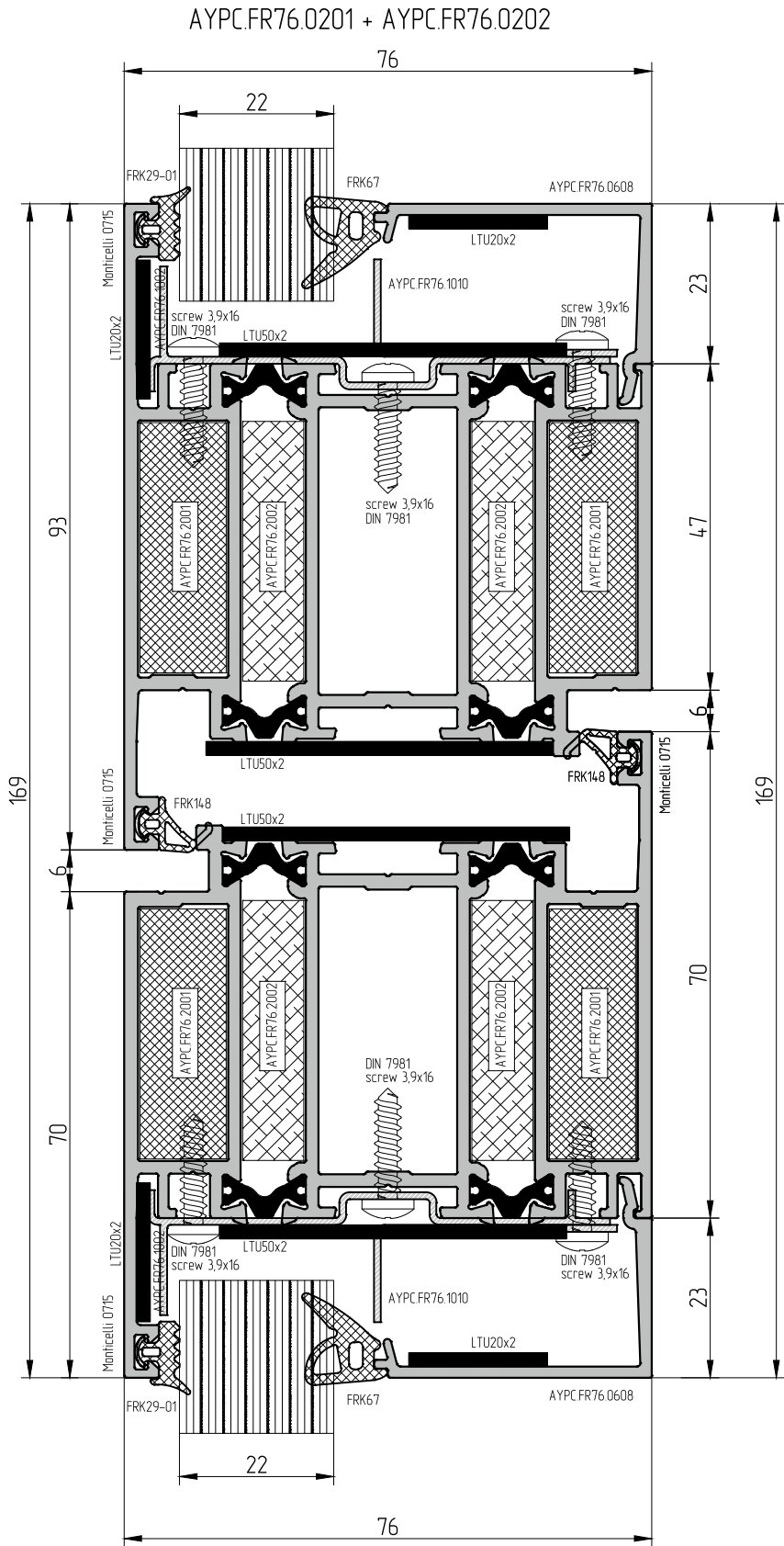
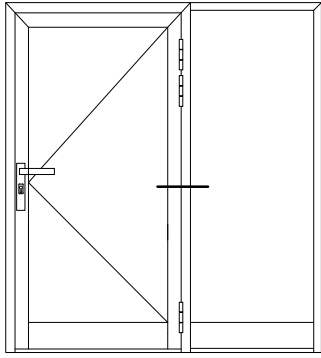
AYPC.FR76.0301 + AYPC.FR76.0803 + AYPC.FR76.0201

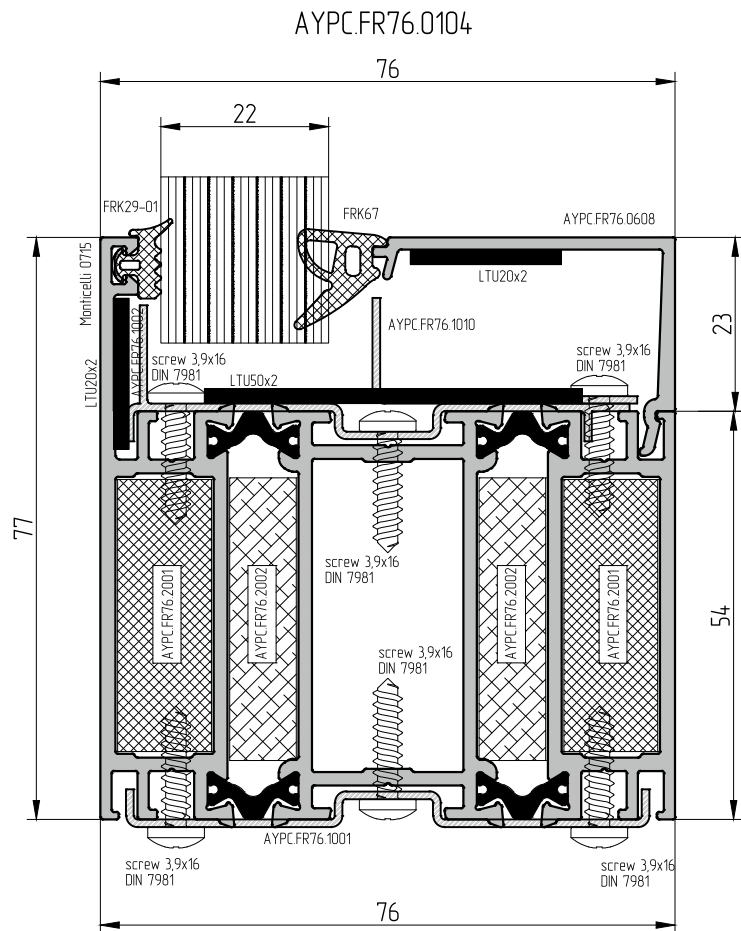
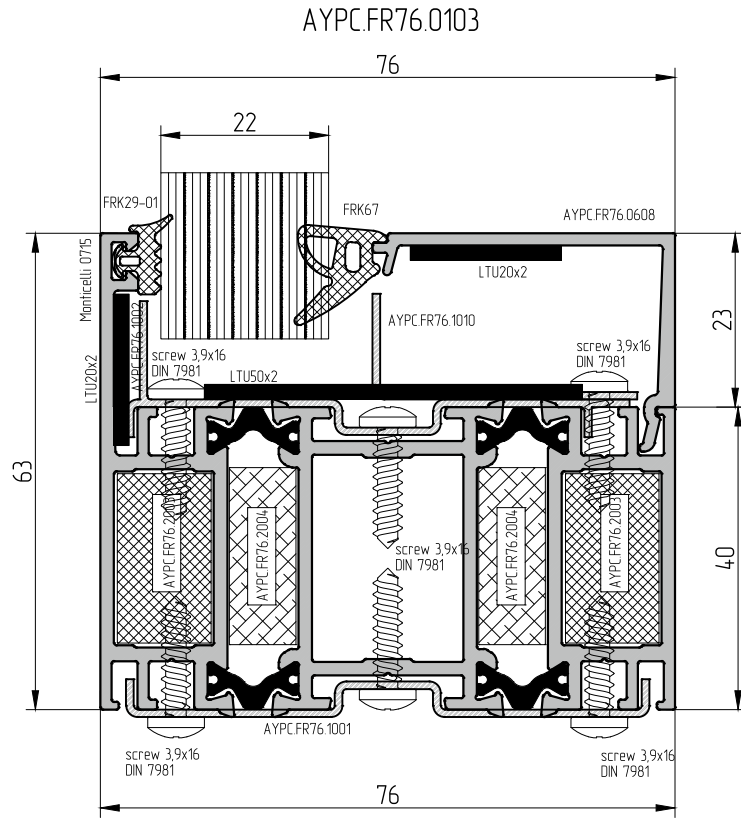
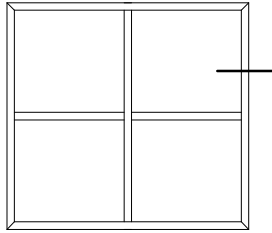


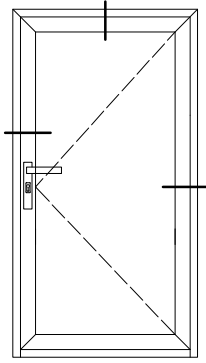


AYPC.FR76.0102 + AYPC.FR76.0201 + AYPC.FR76.0103

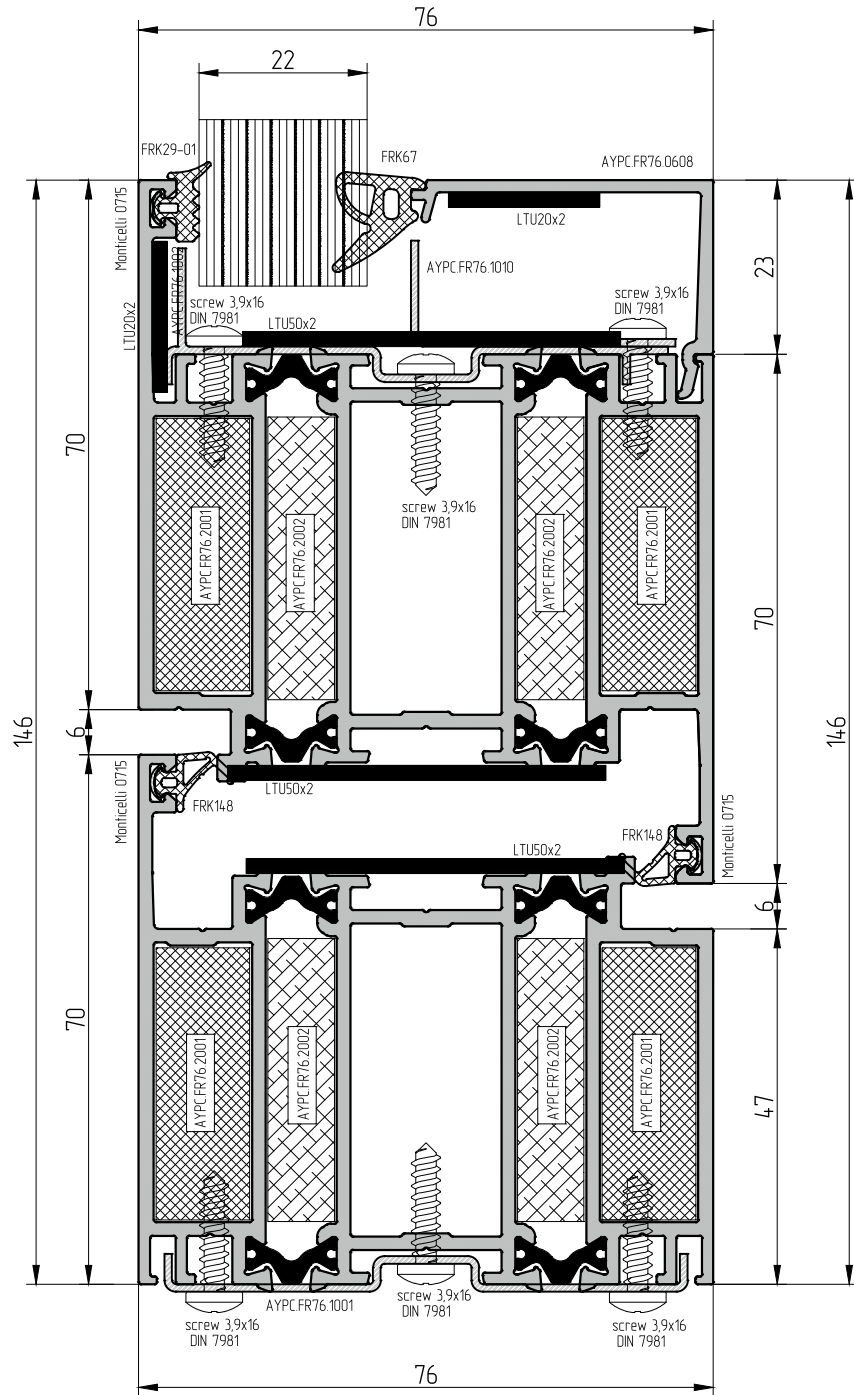


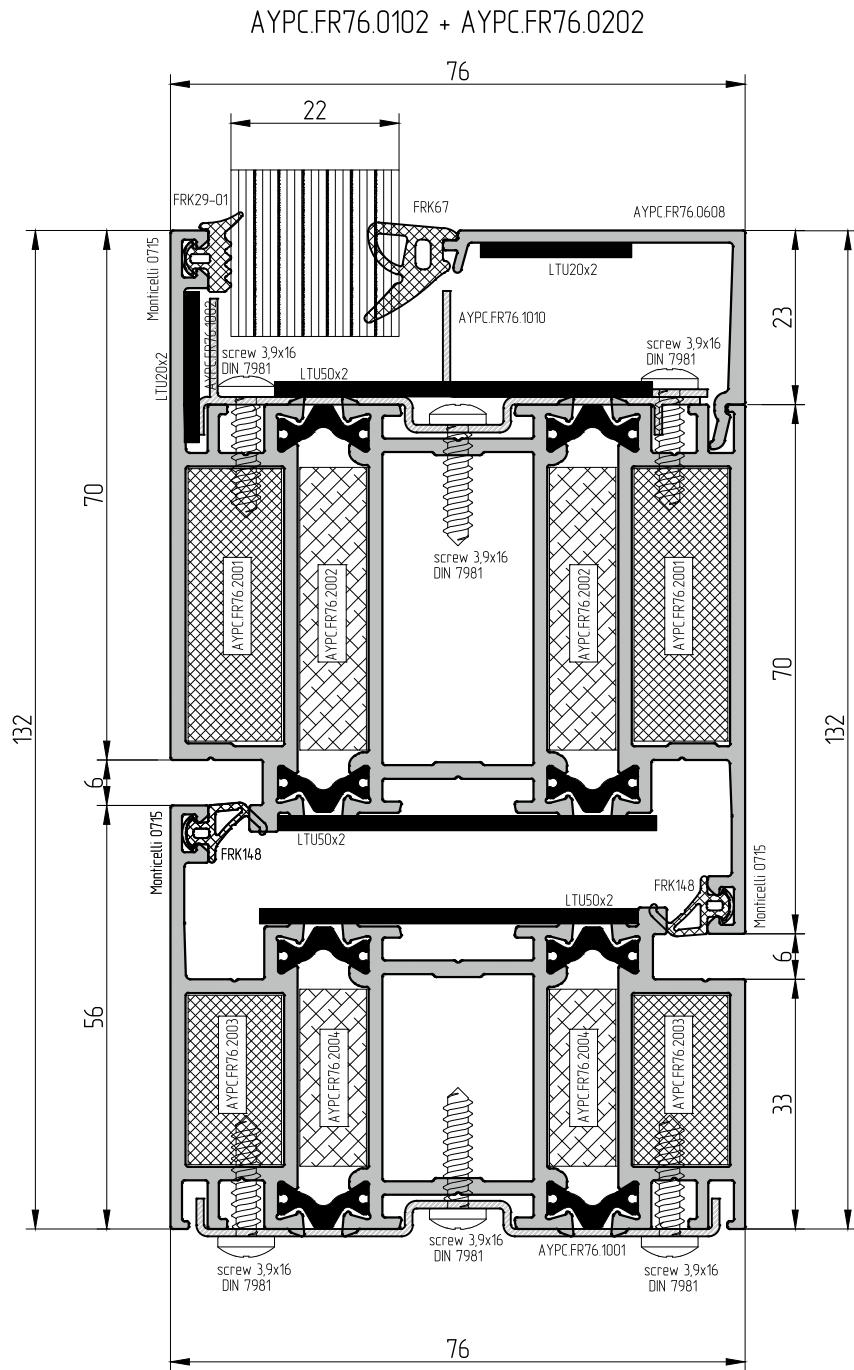
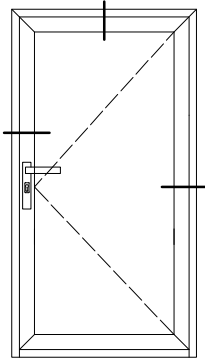


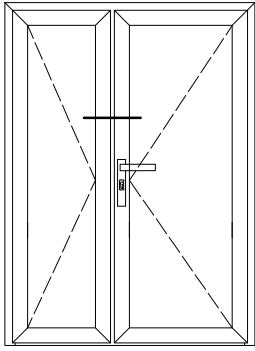




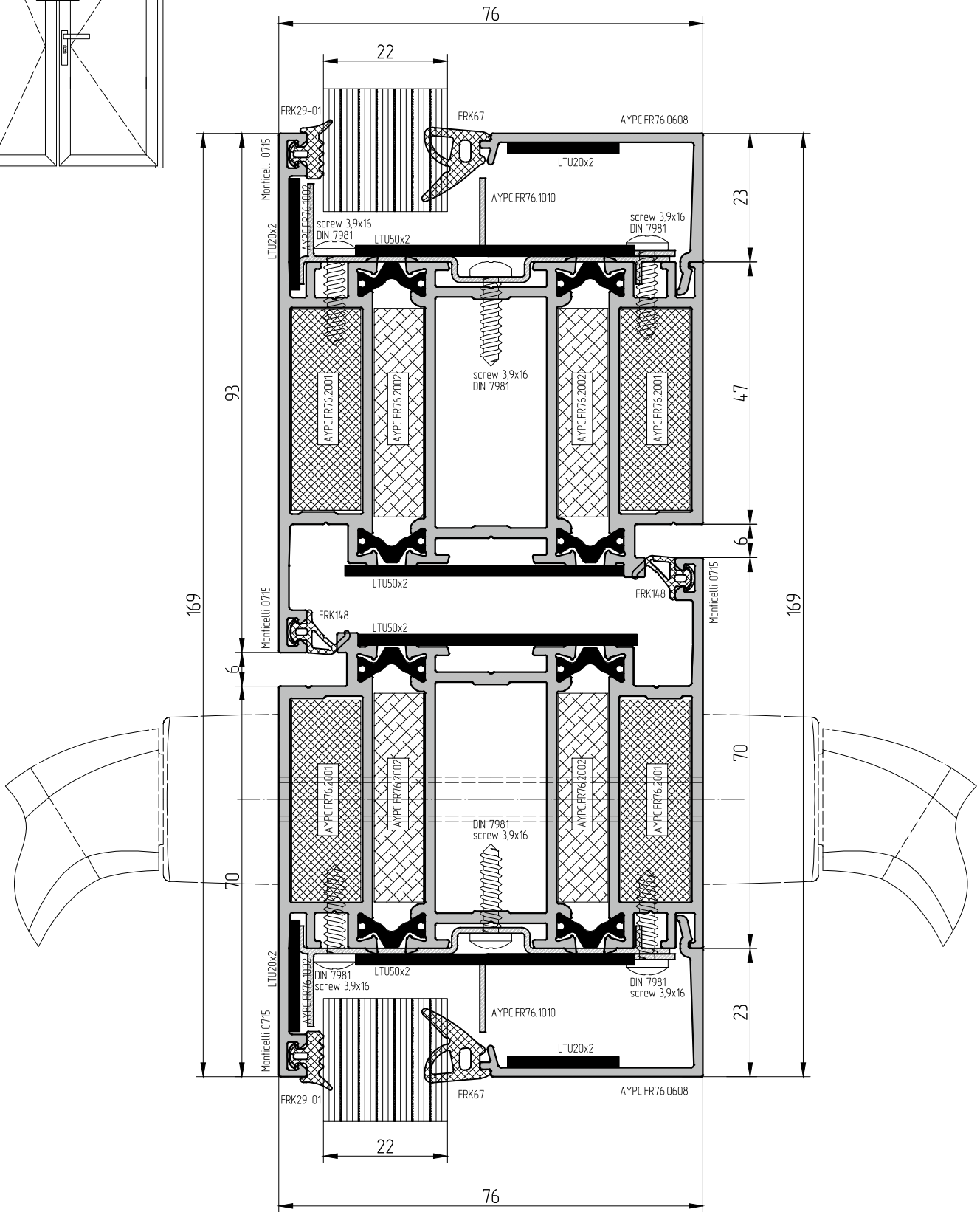
AYPC.FR76.0101 + AYPC.FR76.0202

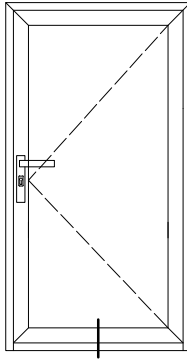




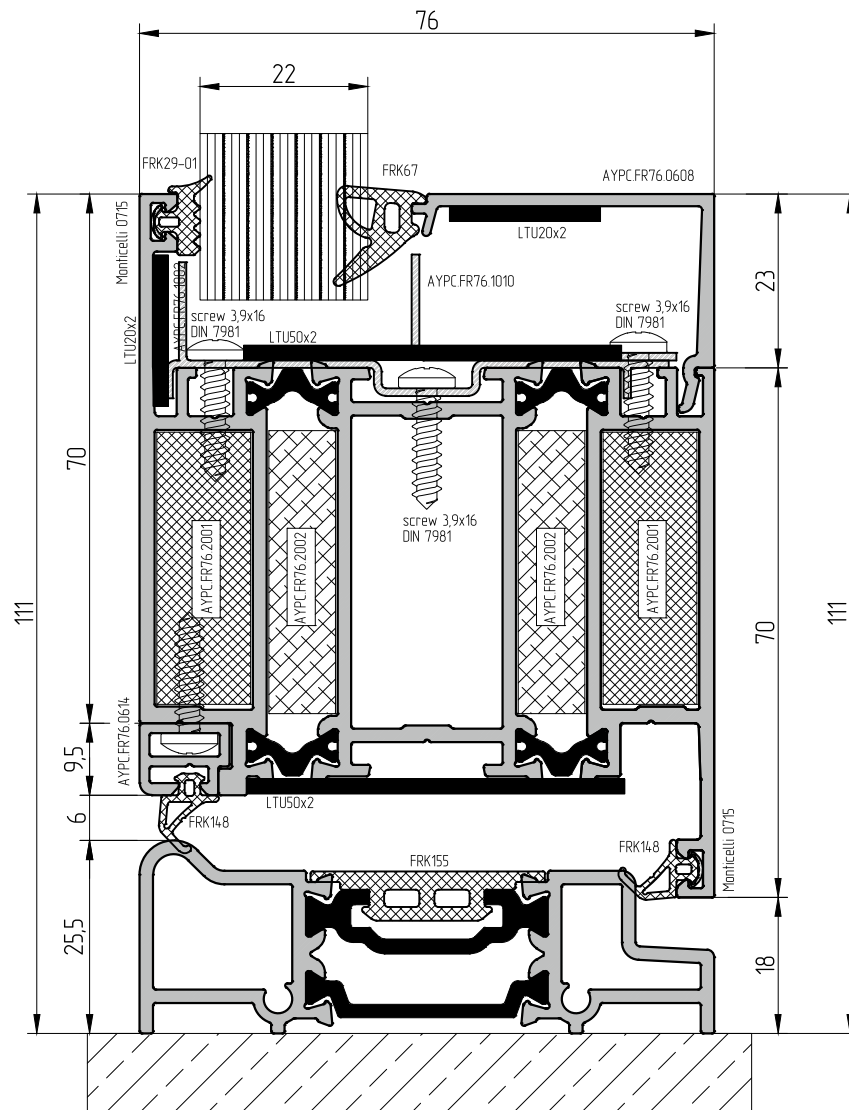


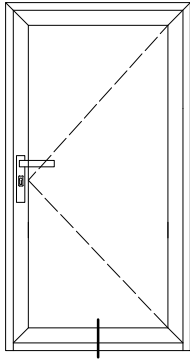
AYPC.FR76.0202 + AYPC.FR76.0201



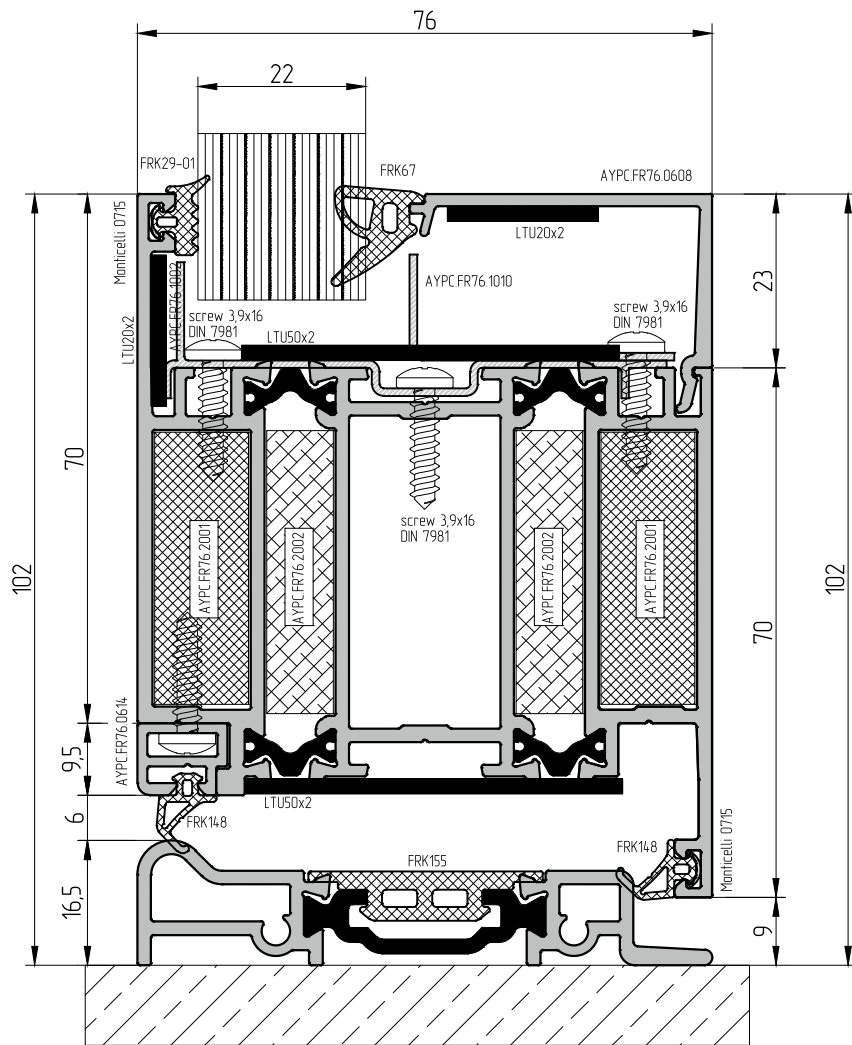


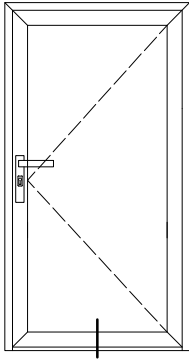
AYPC.FR76.0202 + AYPC.FR76.0801 + AYPC.FR76.0614



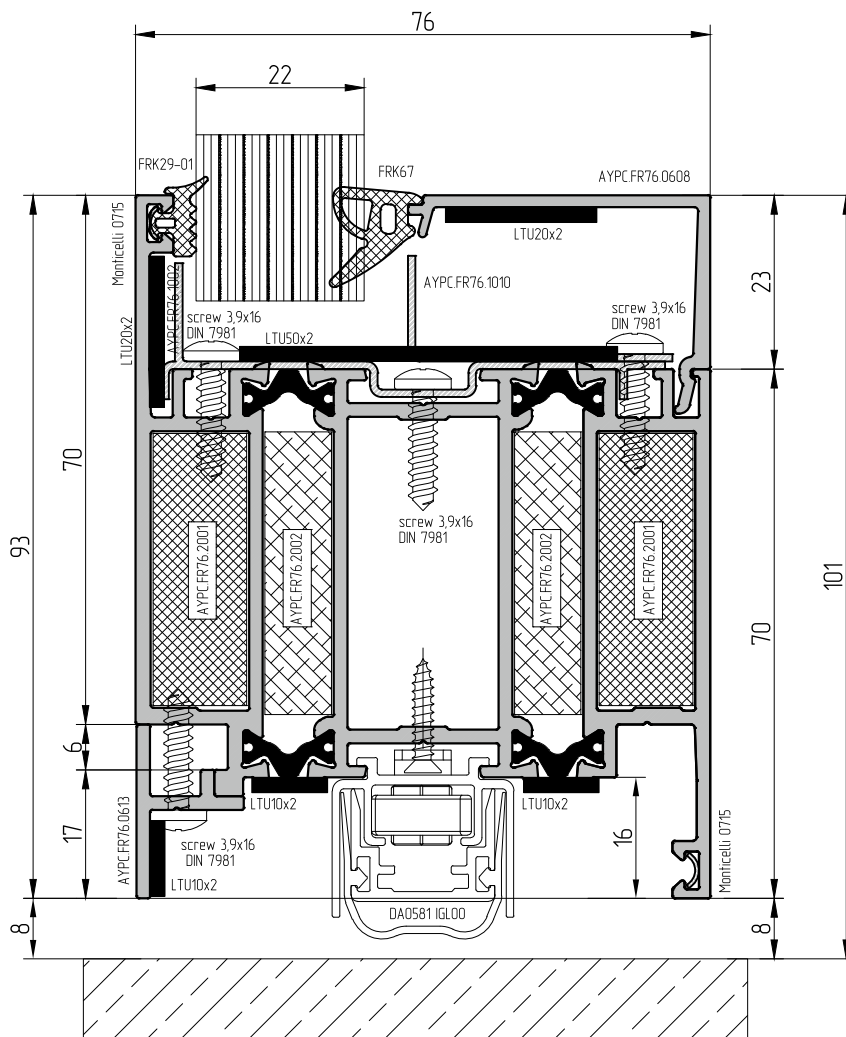


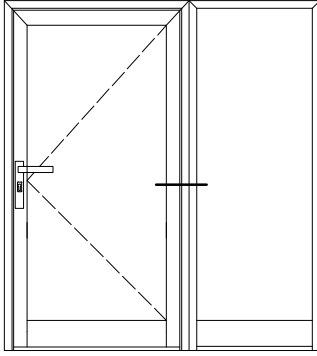
AYPC.FR76.0202 + AYPC.FR76.0802 + AYPC.FR76.0614



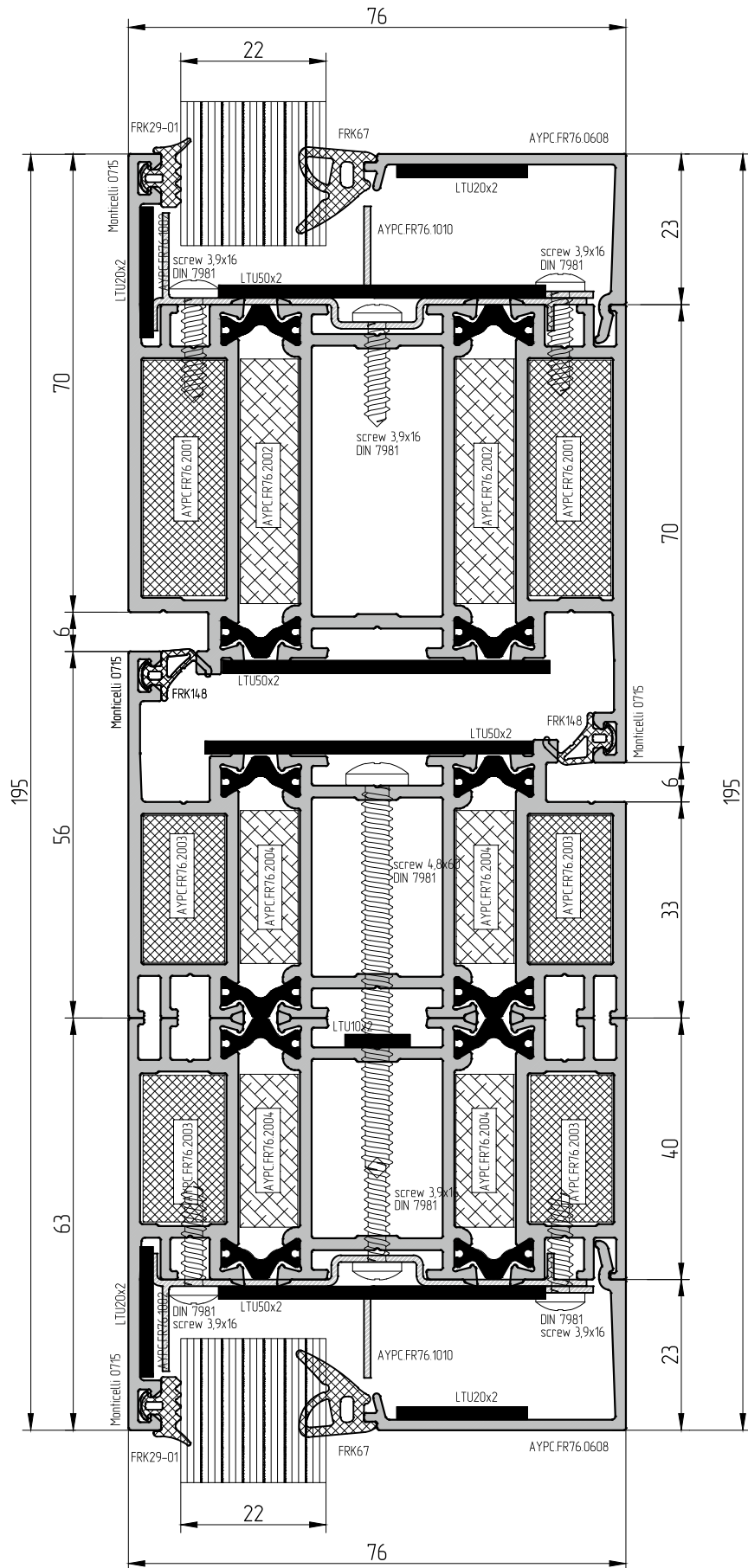


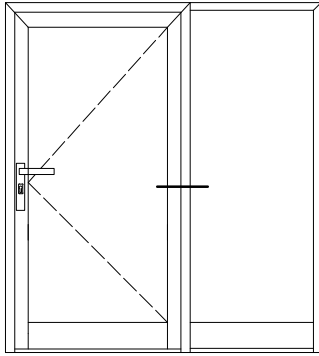
AYPC.FR76.0202 + DA0581 IGL00



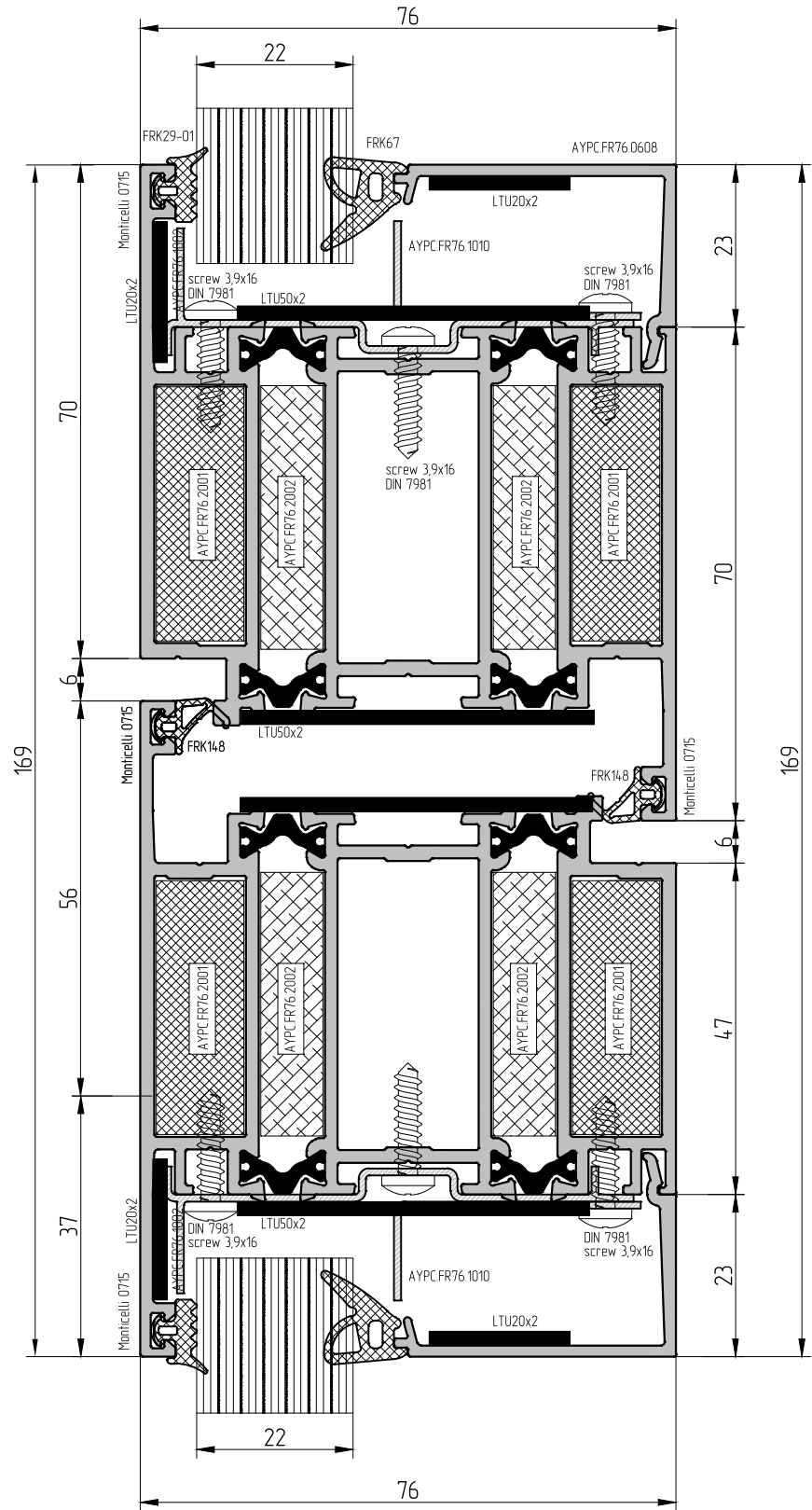


AYPC.FR76.0102 + AYPC.FR76.0202 + AYPC.FR76.0103

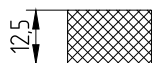
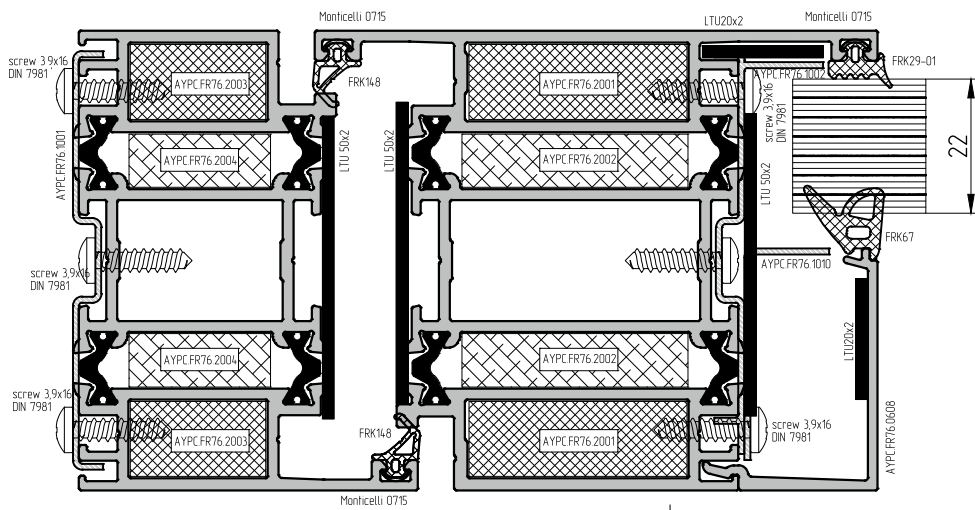
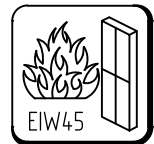
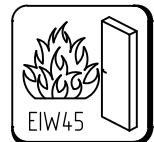
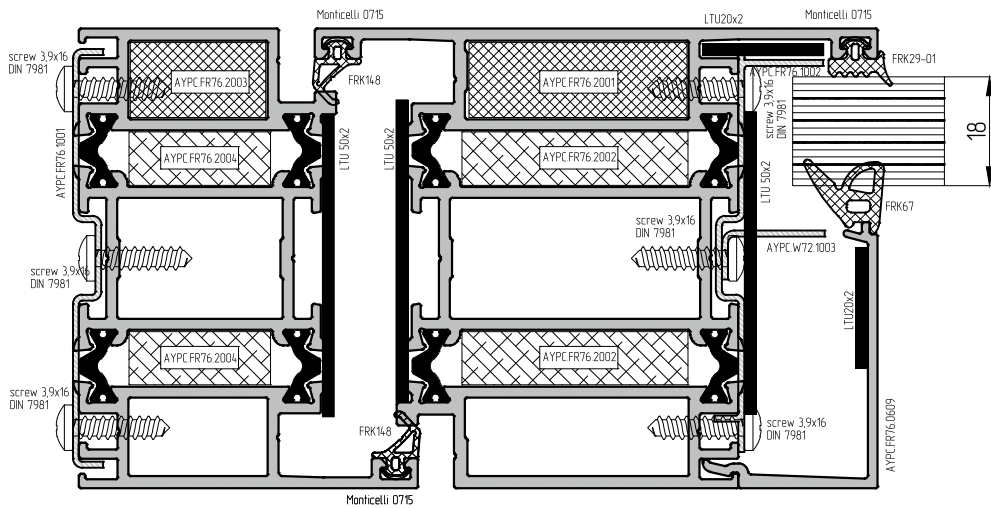
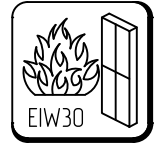
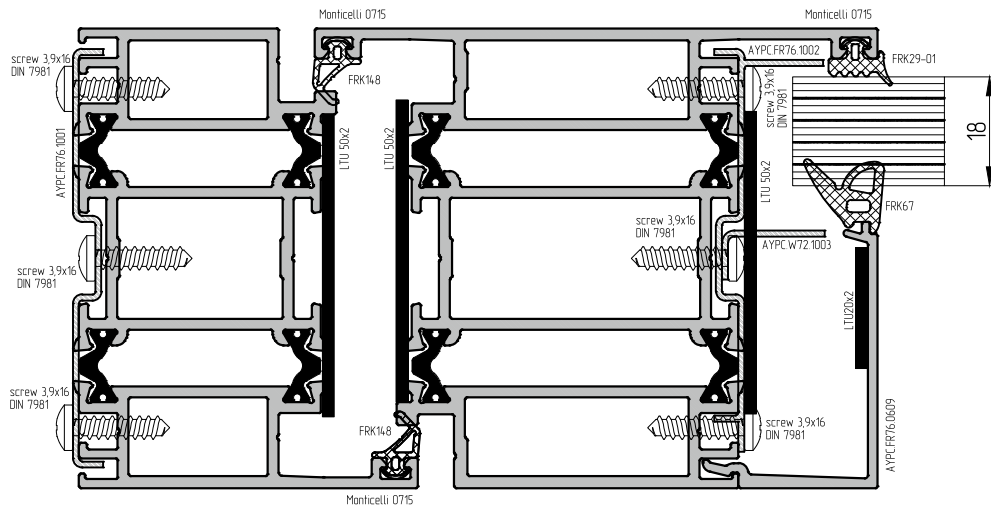




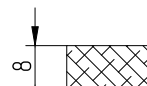
AYPC.FR76.0102 + AYPC.FR76.0202 + AYPC.FR76.0103



Joint solutions depending on fire-resistant rating



- fire-resistant gypsum board FRGB of 12,5 mm



- glass magnesium board (GMB) of 8mm



1. Depending on the requirements to fireproof system, different types of fireproof infill unit of various manufacturers are used.
2. Articles of glass beads and rubber gaskets should be chosen depending on glass thickness (See Chapter 04 - Table of glazing).



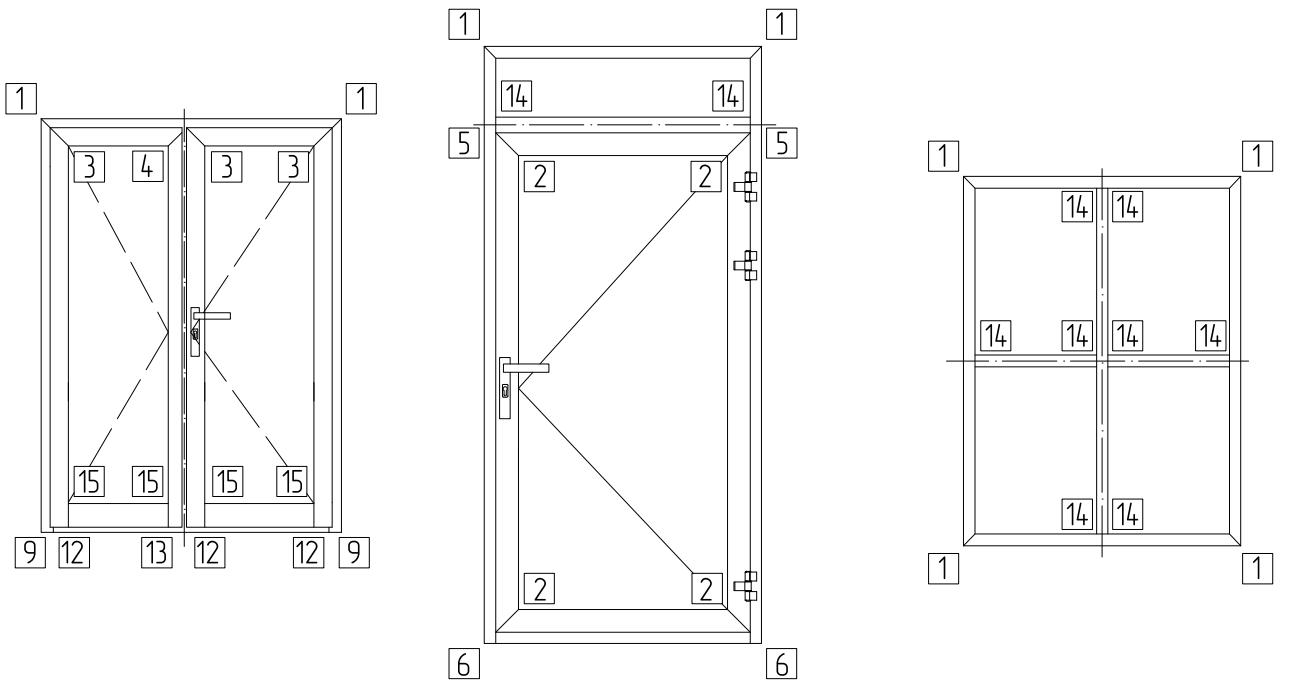
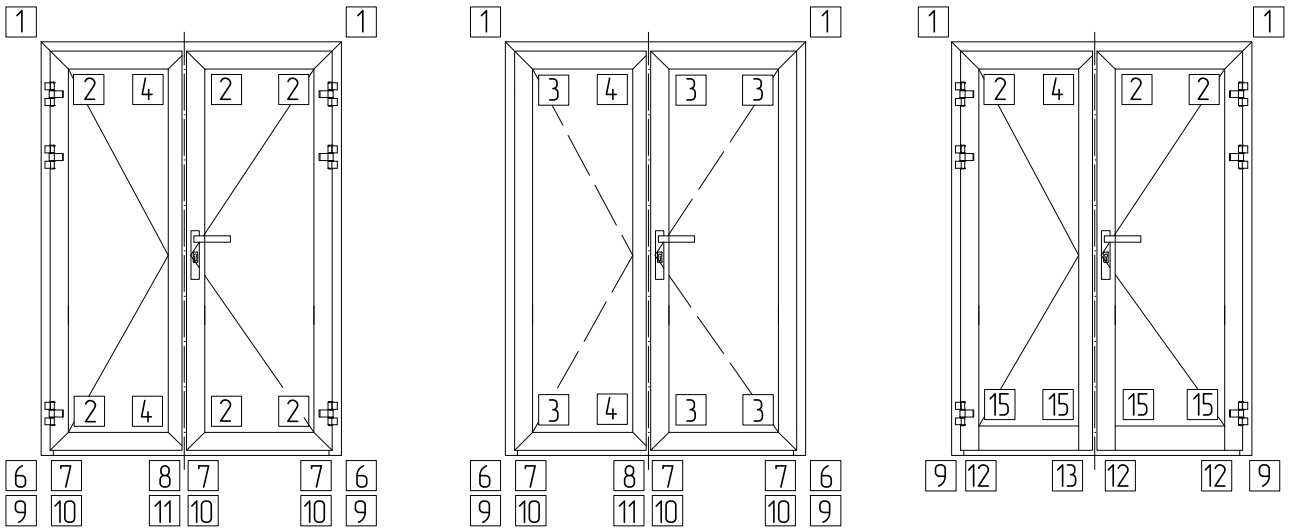
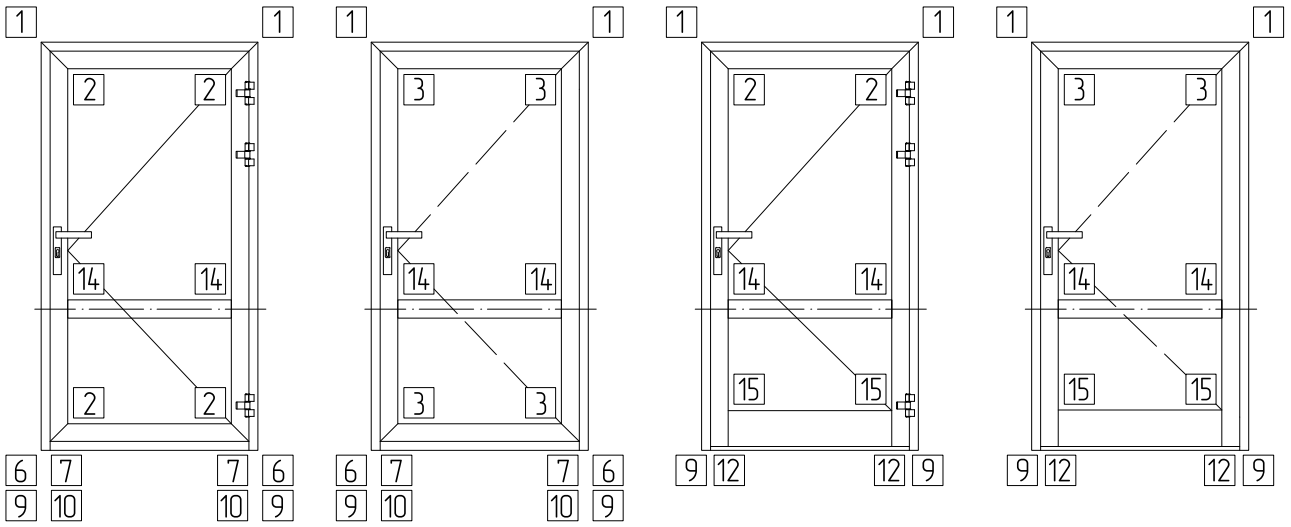
ALT FR76

FIRE RESISTANT
DOORS WITH DOUBLE
THERMAL BREAK

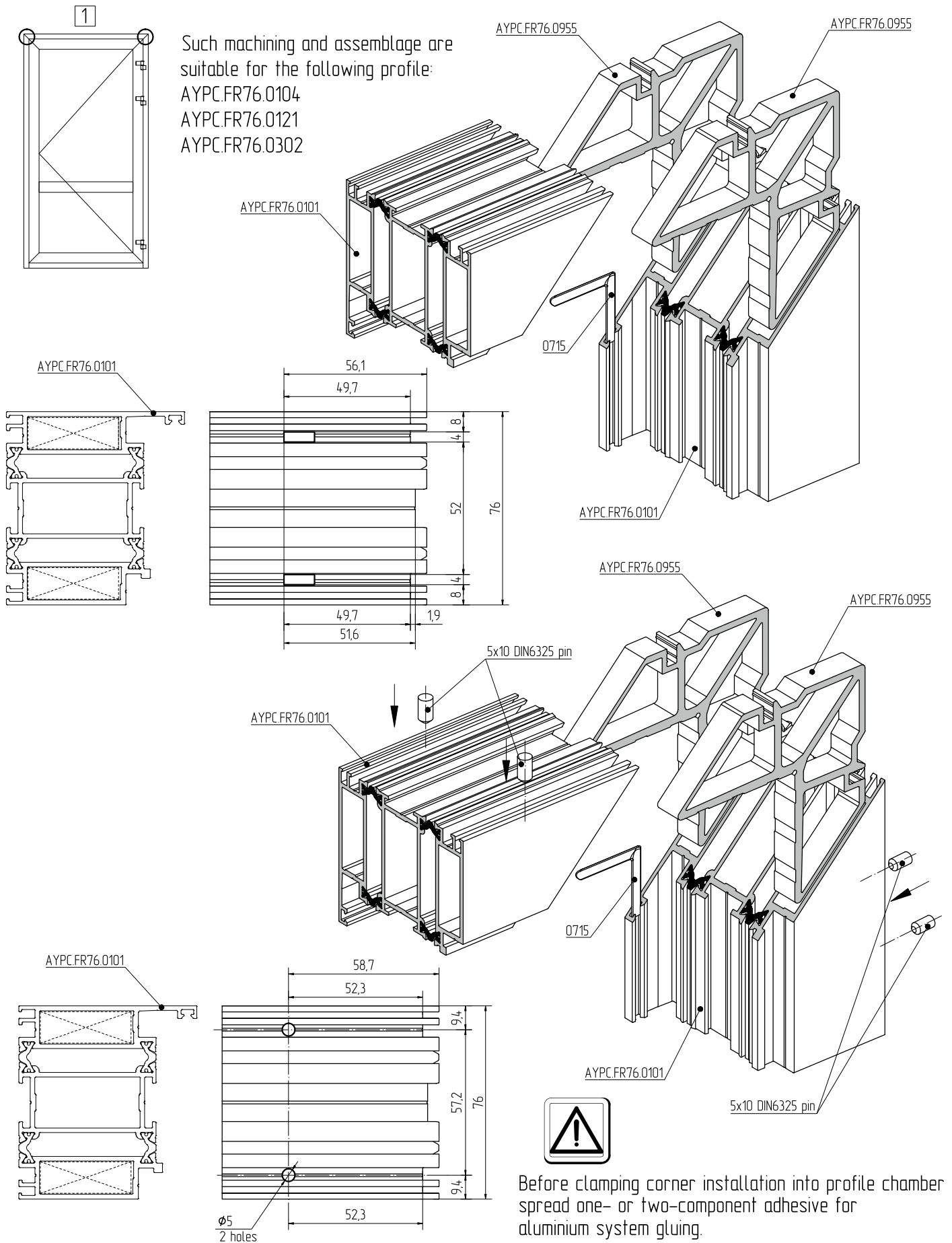
MACHINING
AND
ASSEMBLAGE
OF PROFILES

06

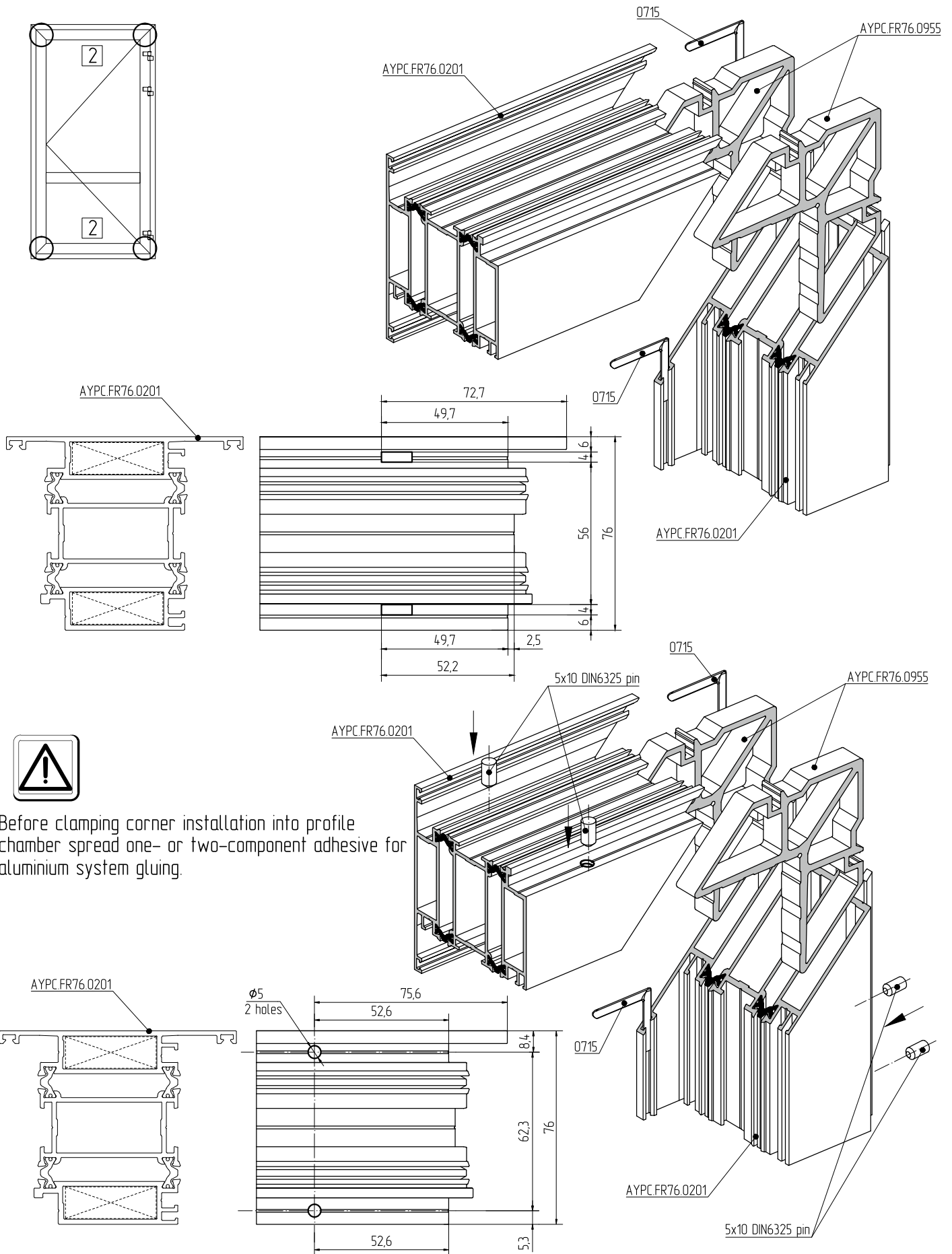
System solutions



Corner connexion of AYPC.FR76.0101 profile by clamping and pins 5x10

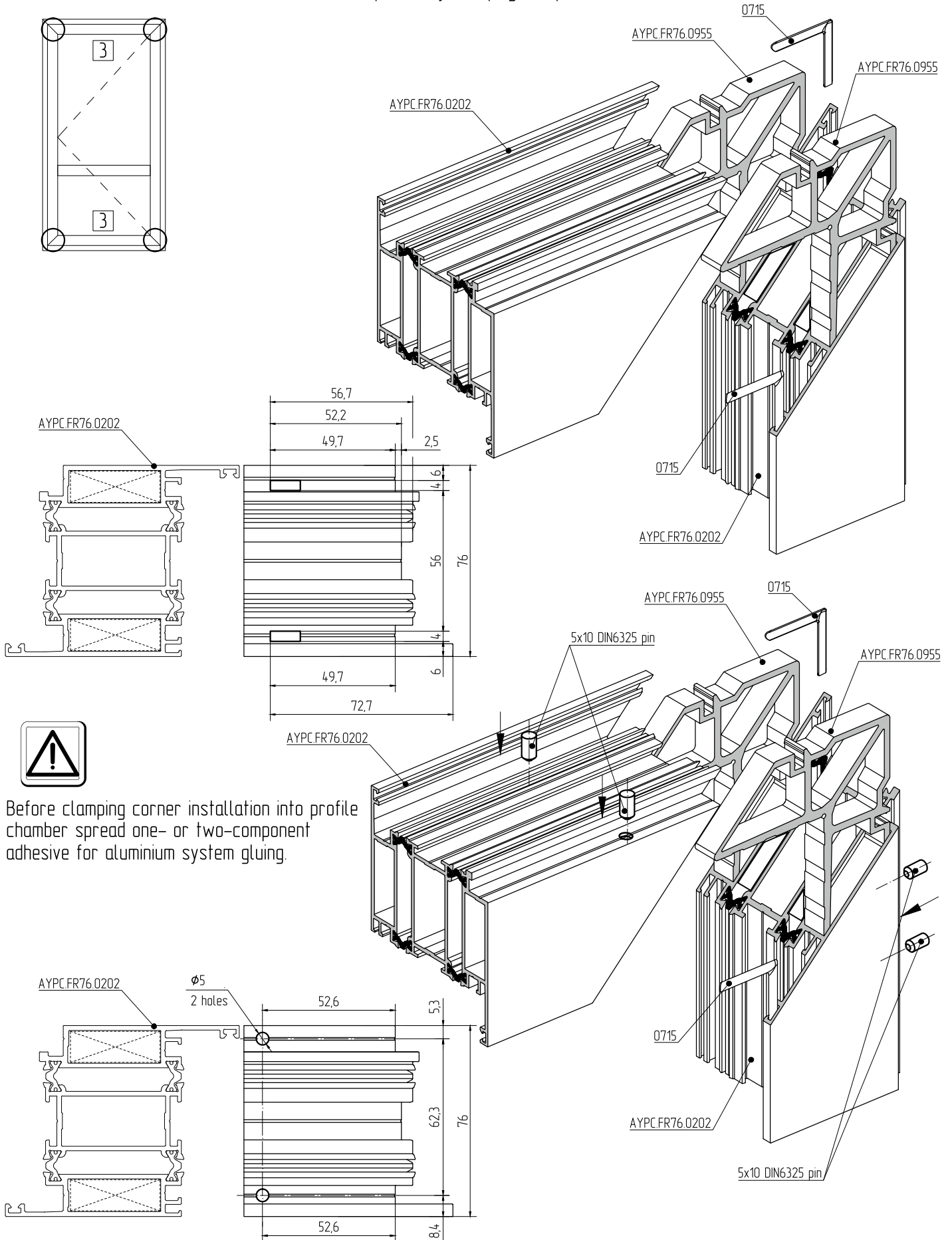


Corner connexion of AYPC.FR76.0201 profile by clamping and pins 5x10

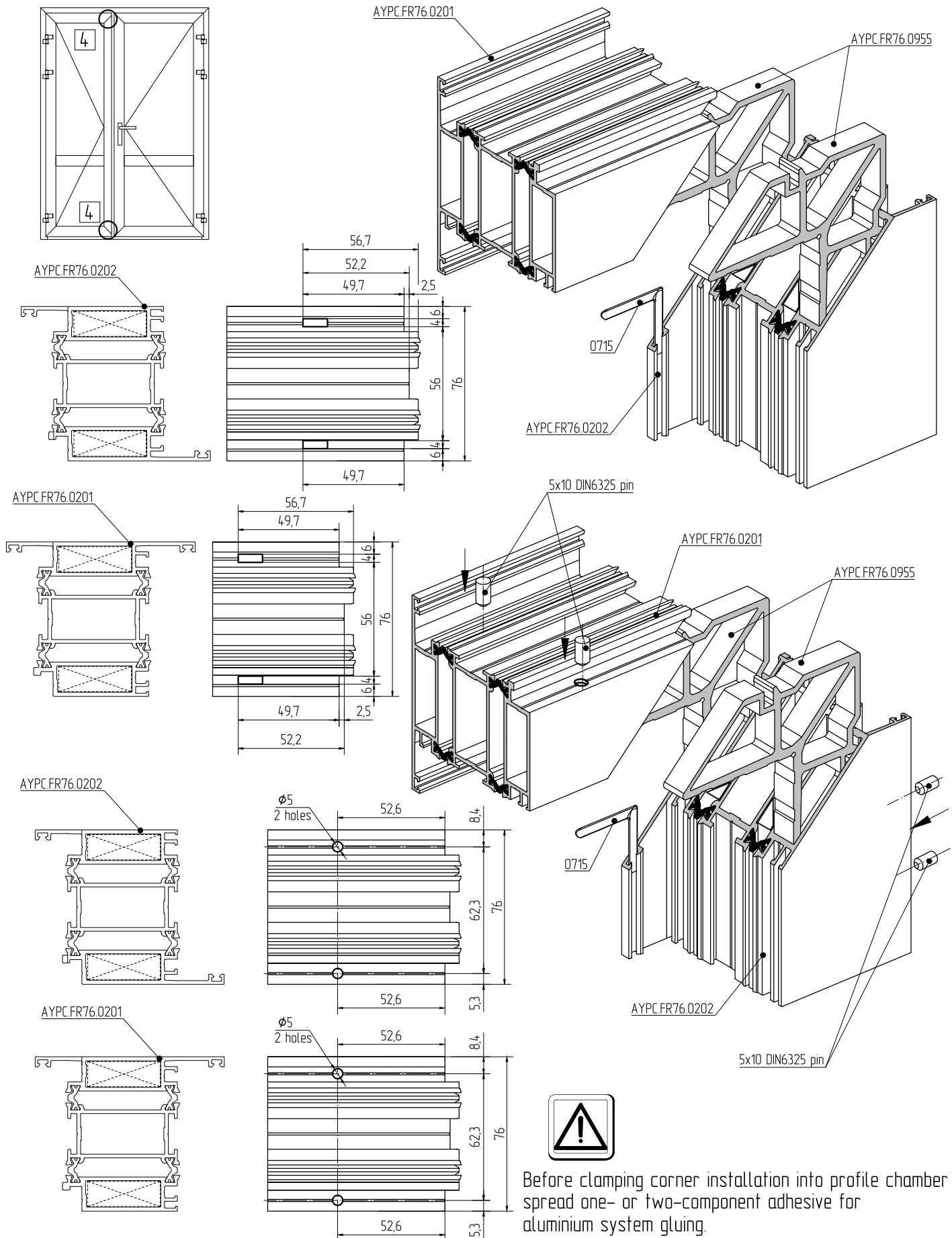


Before clamping corner installation into profile chamber spread one- or two-component adhesive for aluminium system gluing.

Corner connexion of AYPC.FR76.0202 profile by clamping and pins 5x10

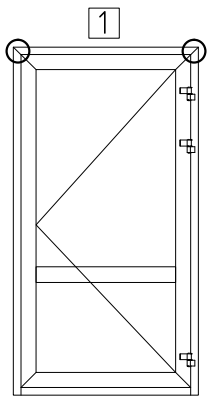


Corner connexion of AYPC.FR76.0201 and AYPC.FR76.0202 profiles by clamping and pins 5x10



Before clamping corner installation into profile chamber spread one- or two-component adhesive for aluminium system gluing.

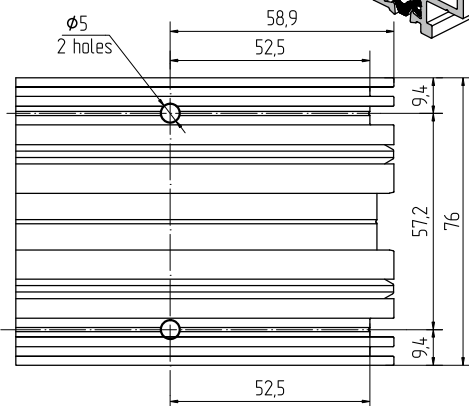
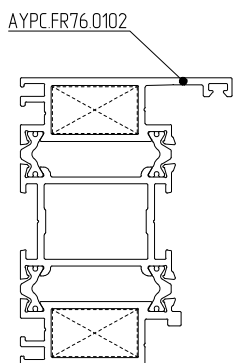
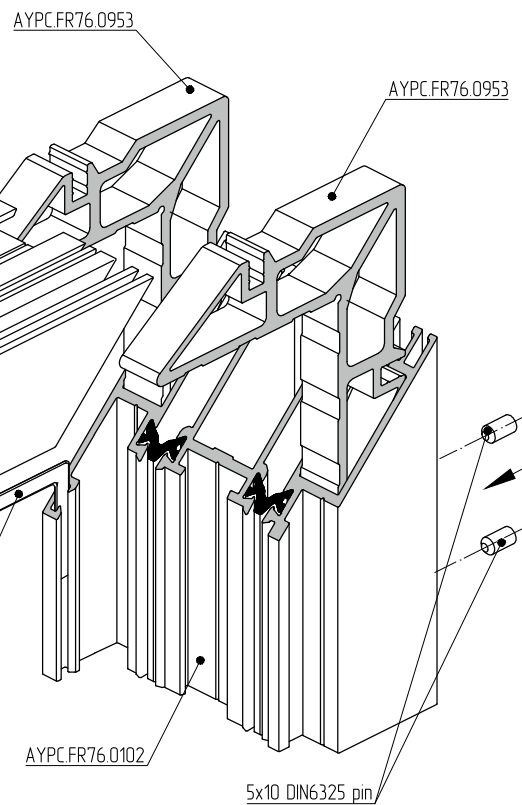
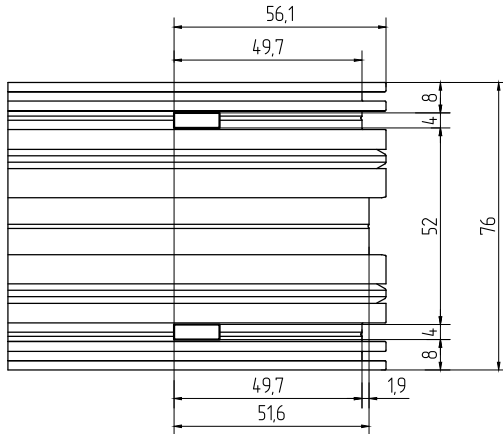
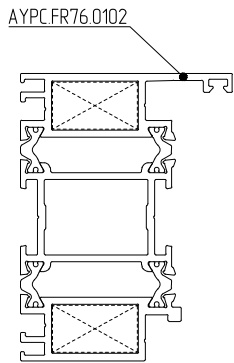
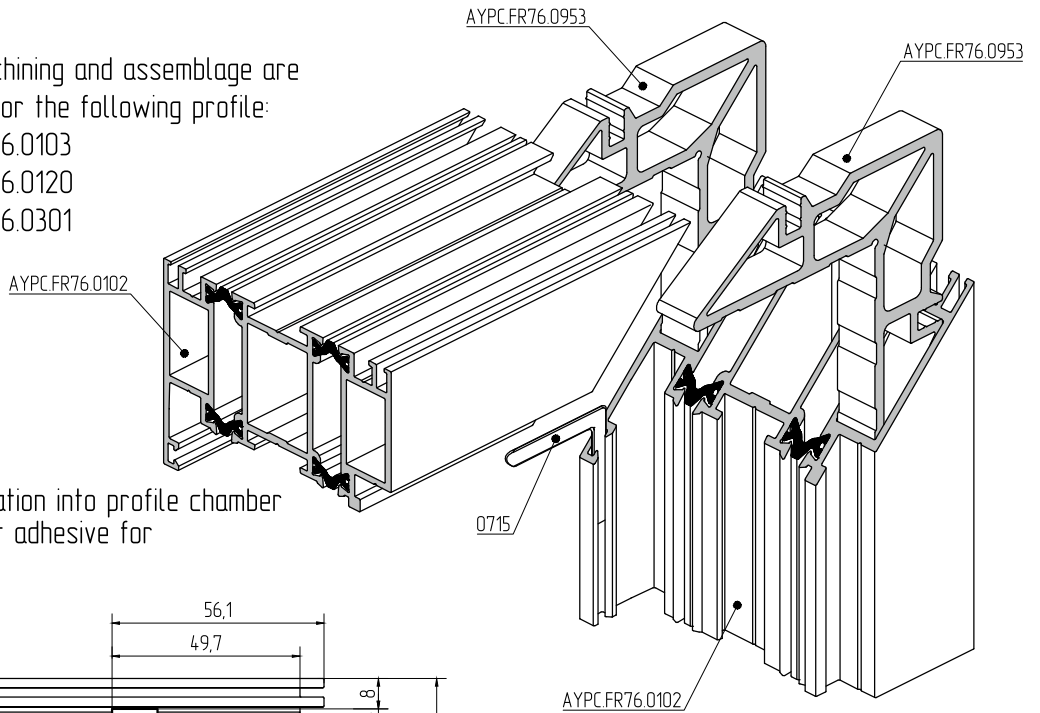
Corner connexion of AYPC.FR76.0102 profiles by clamping and pins 5x10



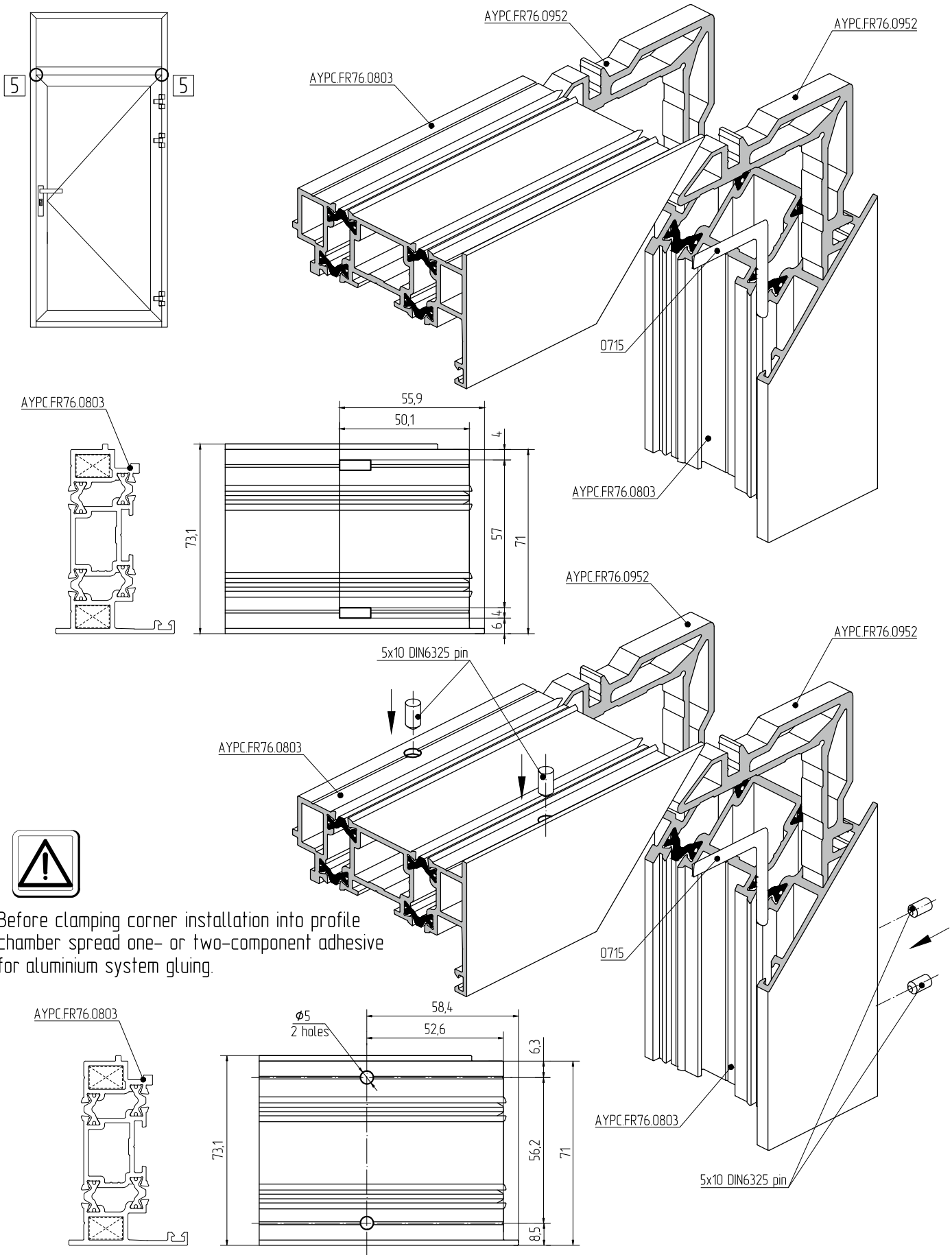
Such machining and assemblage are suitable for the following profile:
AYPC.FR76.0103
AYPC.FR76.0120
AYPC.FR76.0301



Before clamping corner installation into profile chamber spread one- or two-component adhesive for aluminium system gluing.

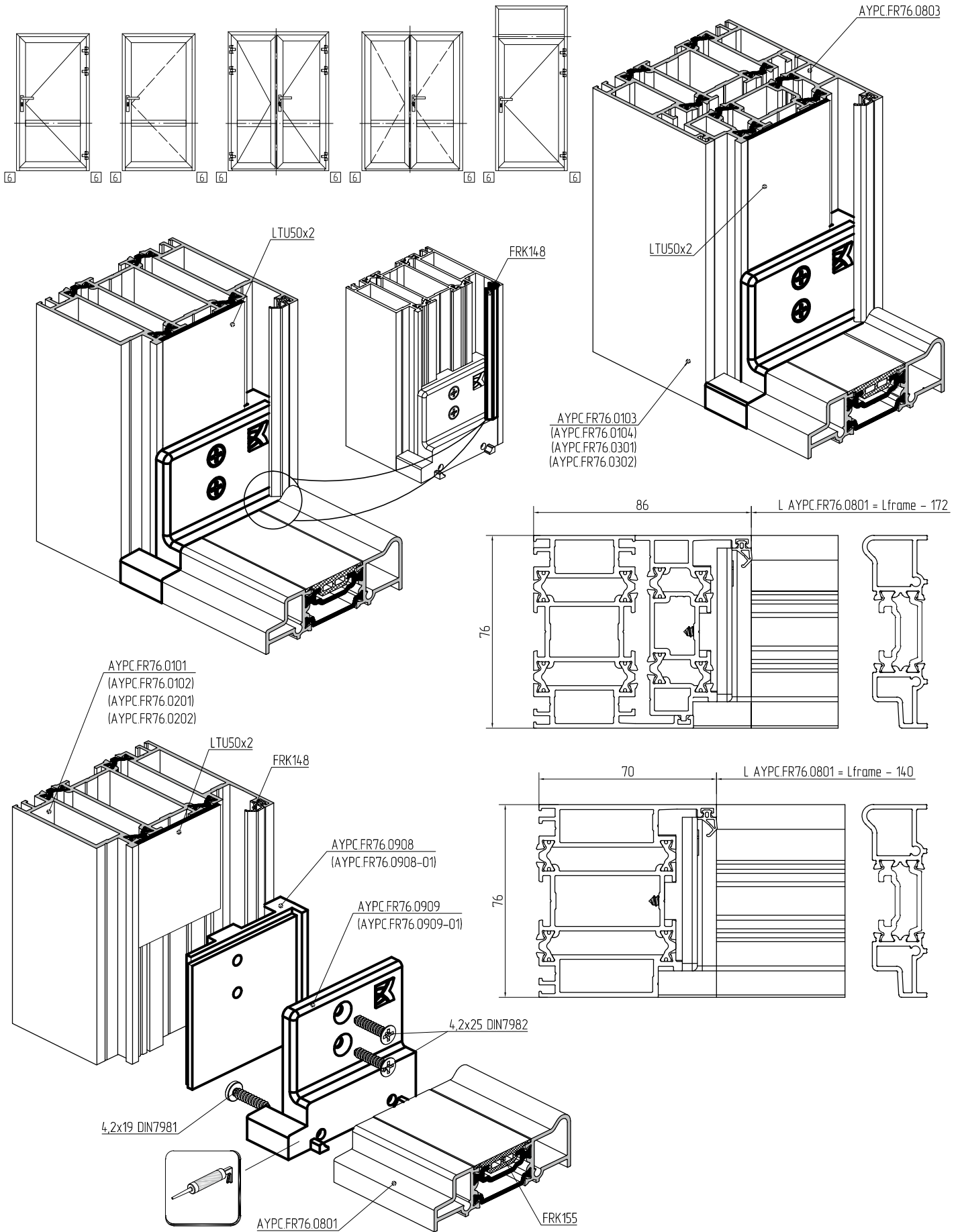


Corner connexion of AYPC.FR76.0803 profiles by clamping and pins 5x10

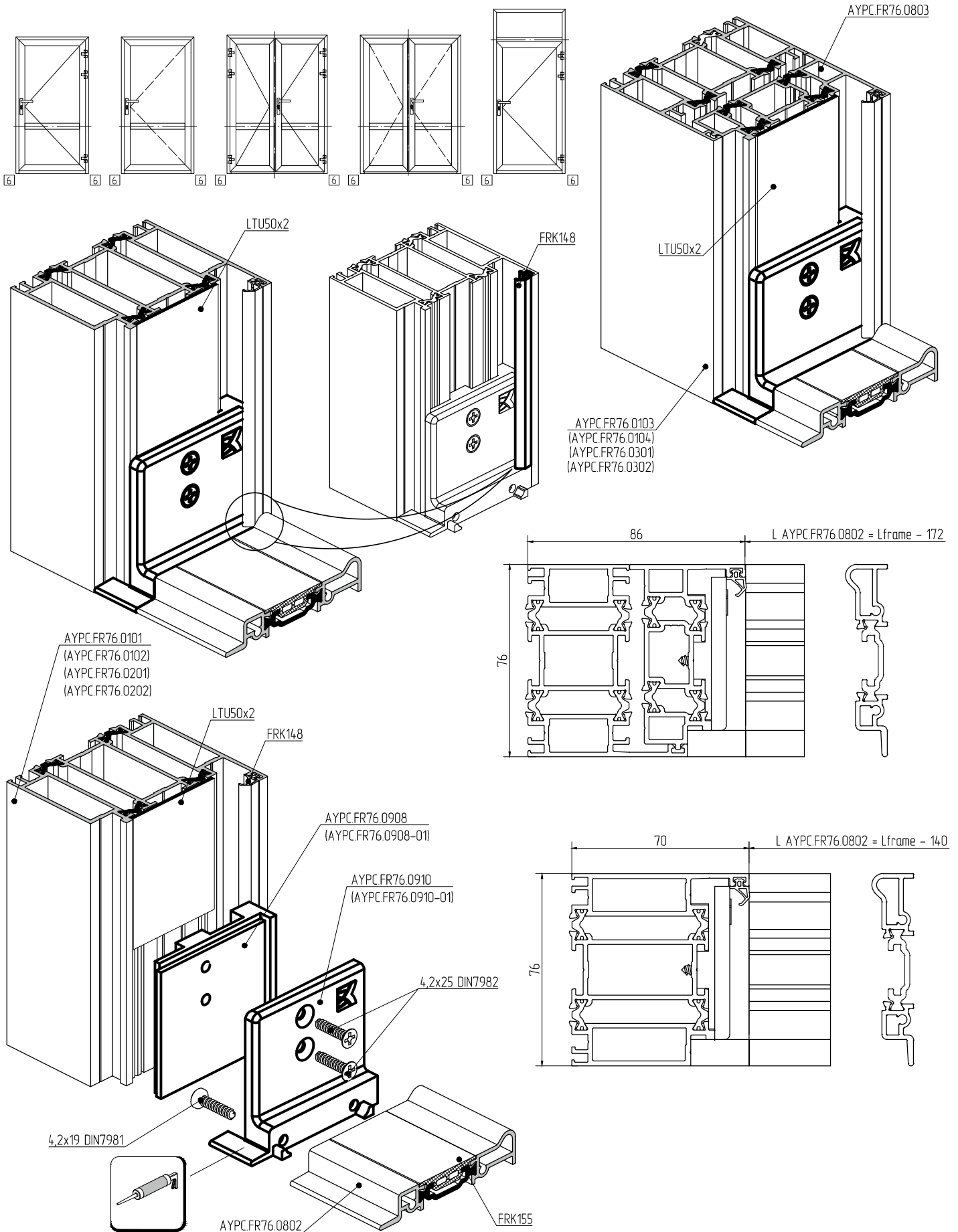


Before clamping corner installation into profile chamber spread one- or two-component adhesive for aluminium system gluing.

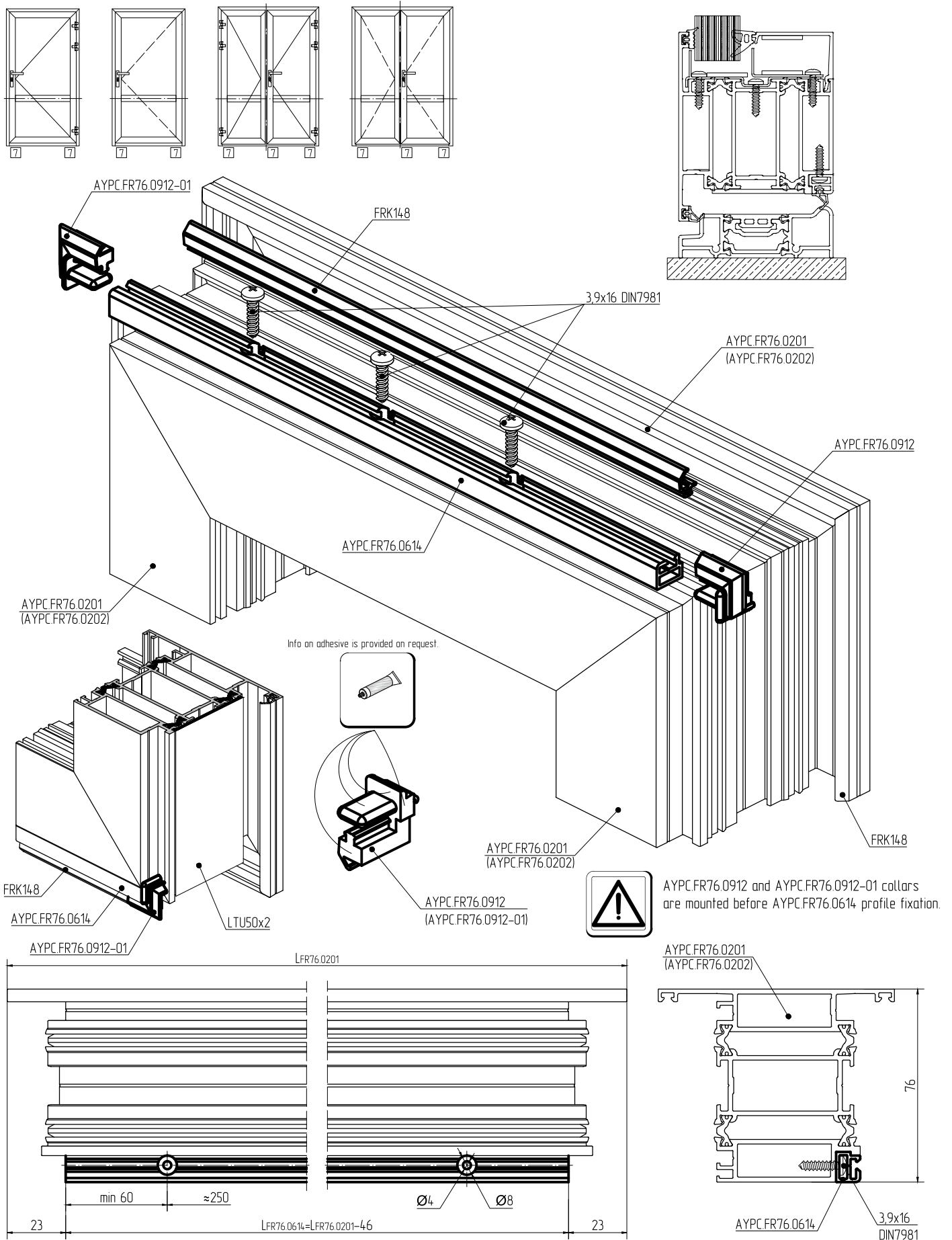
Scheme of AYPC.FR76.0801 threshold profile installation



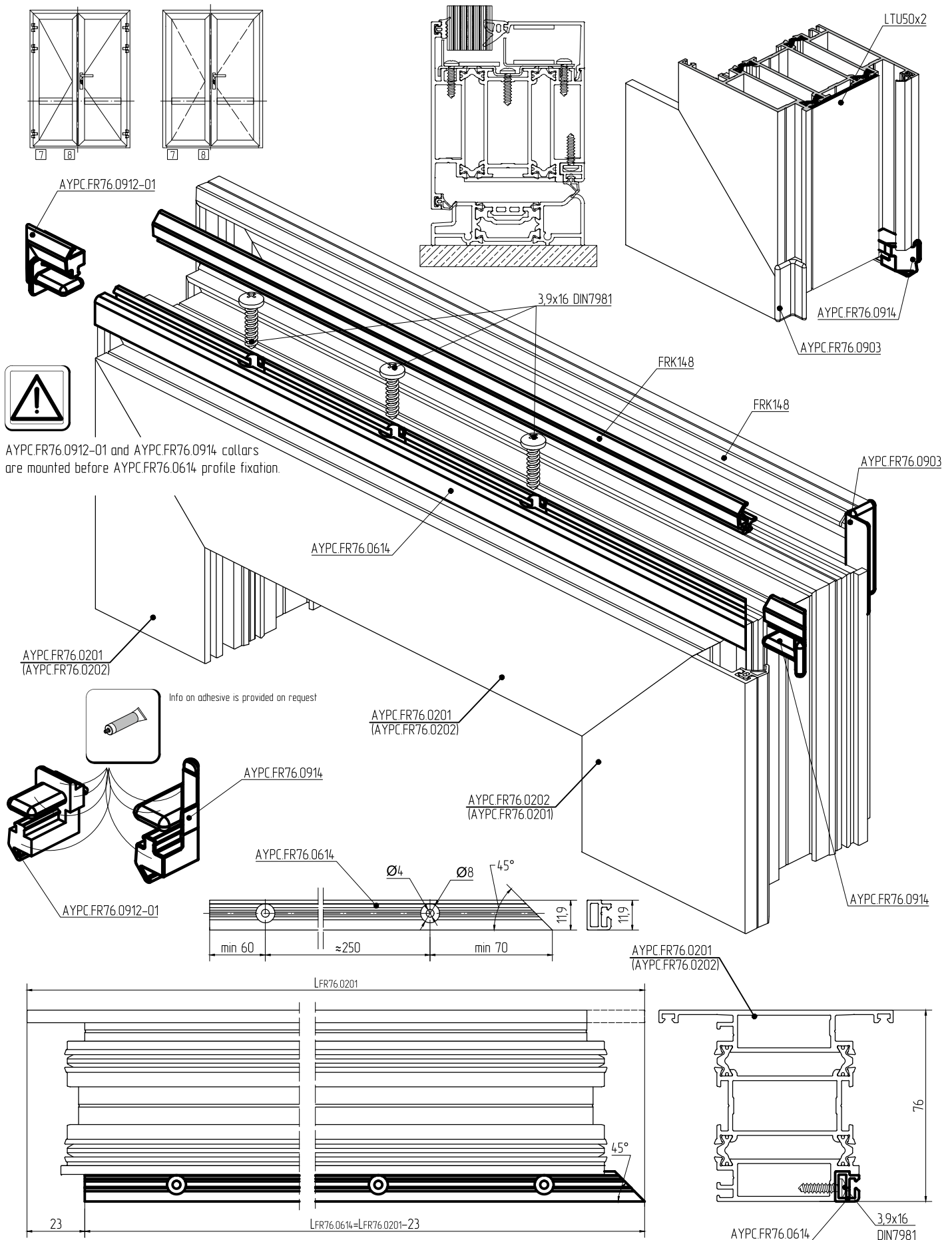
Scheme of AYPC.FR76.0802 threshold profile installation



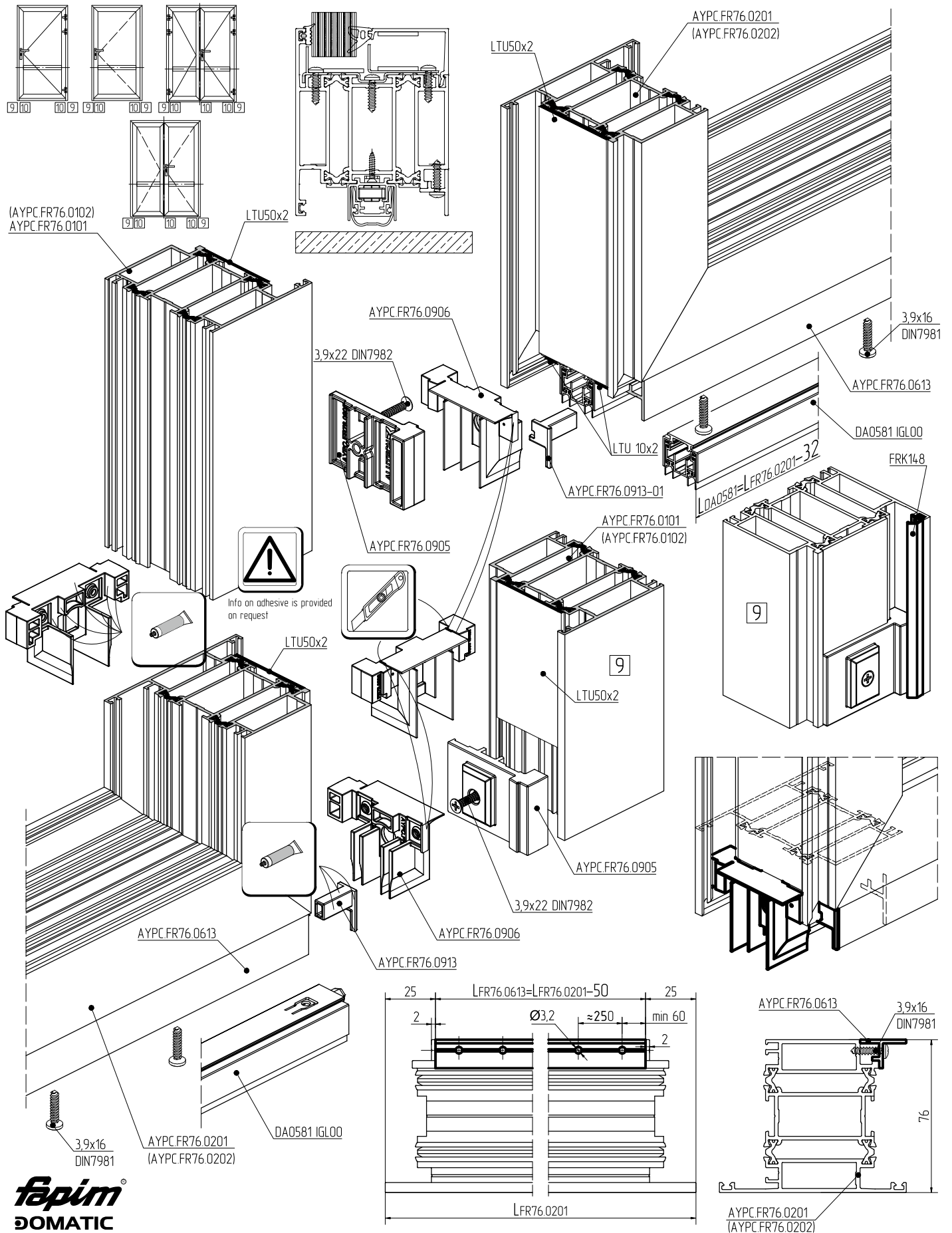
Scheme of machining and assemblage of the lower fire-resistant door system part



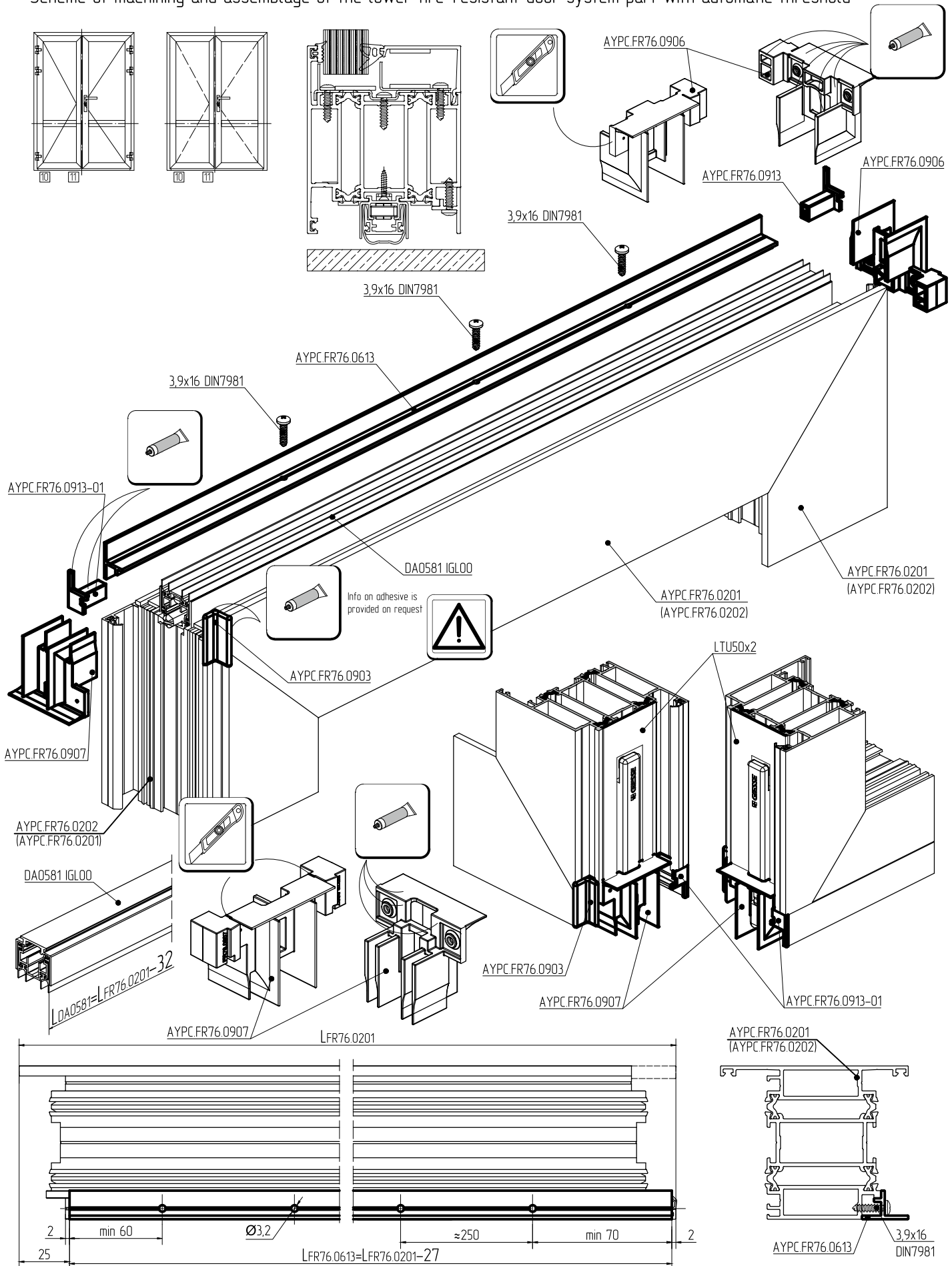
Scheme of machining and assemblage of the lower fire-resistant door system part



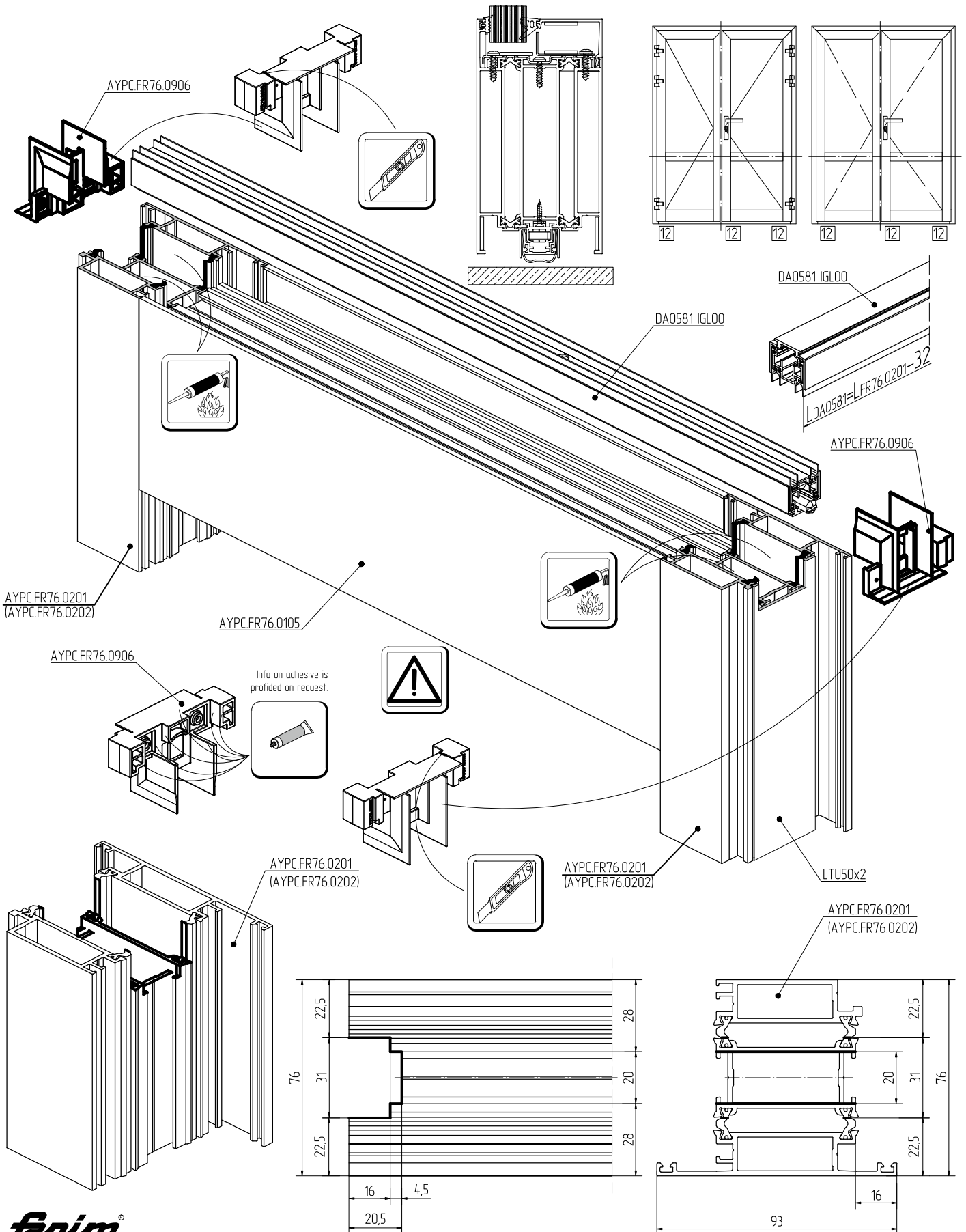
Scheme of machining and assemblage of the lower fire-resistant door system part with automatic threshold



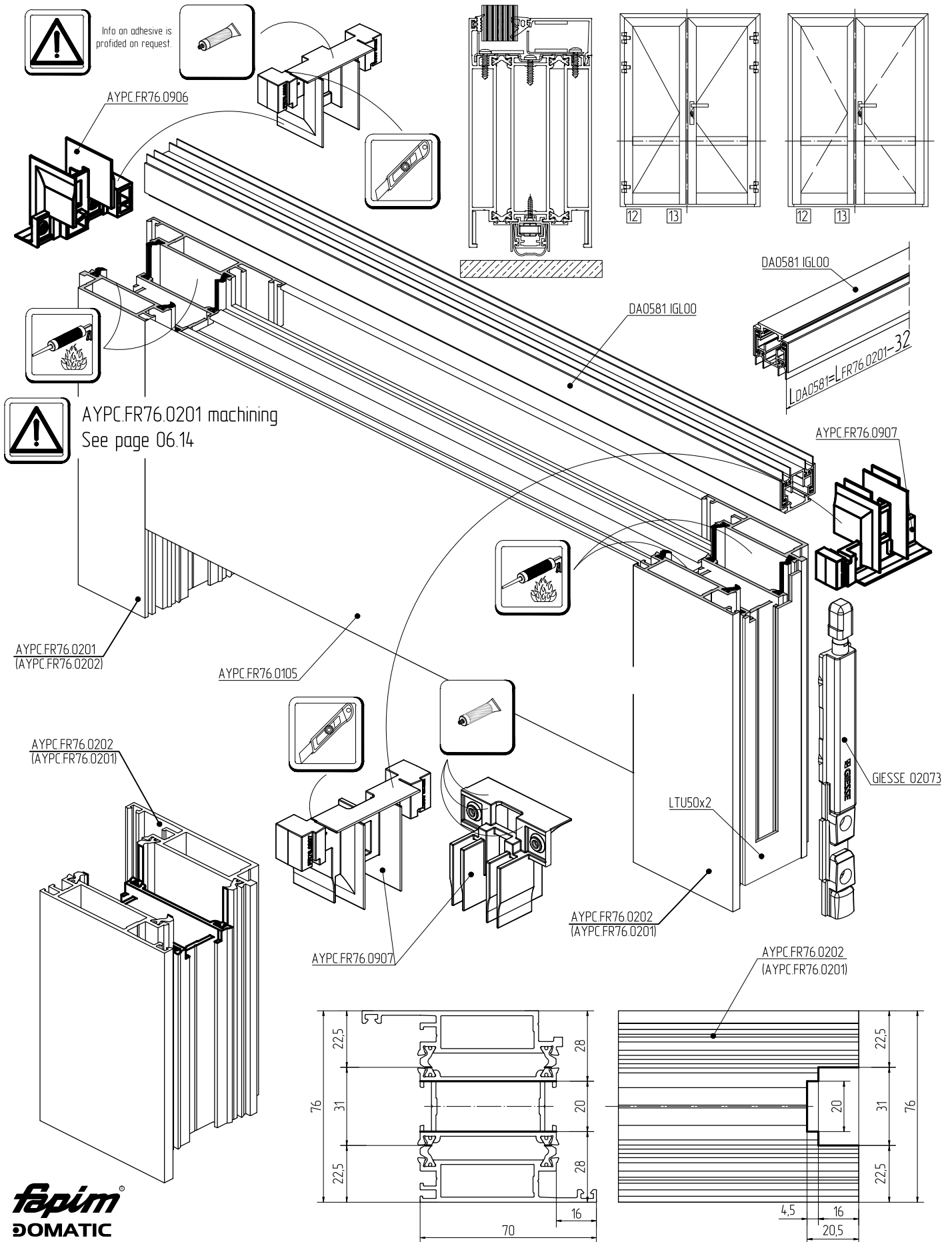
Scheme of machining and assemblage of the lower fire-resistant door system part with automatic threshold



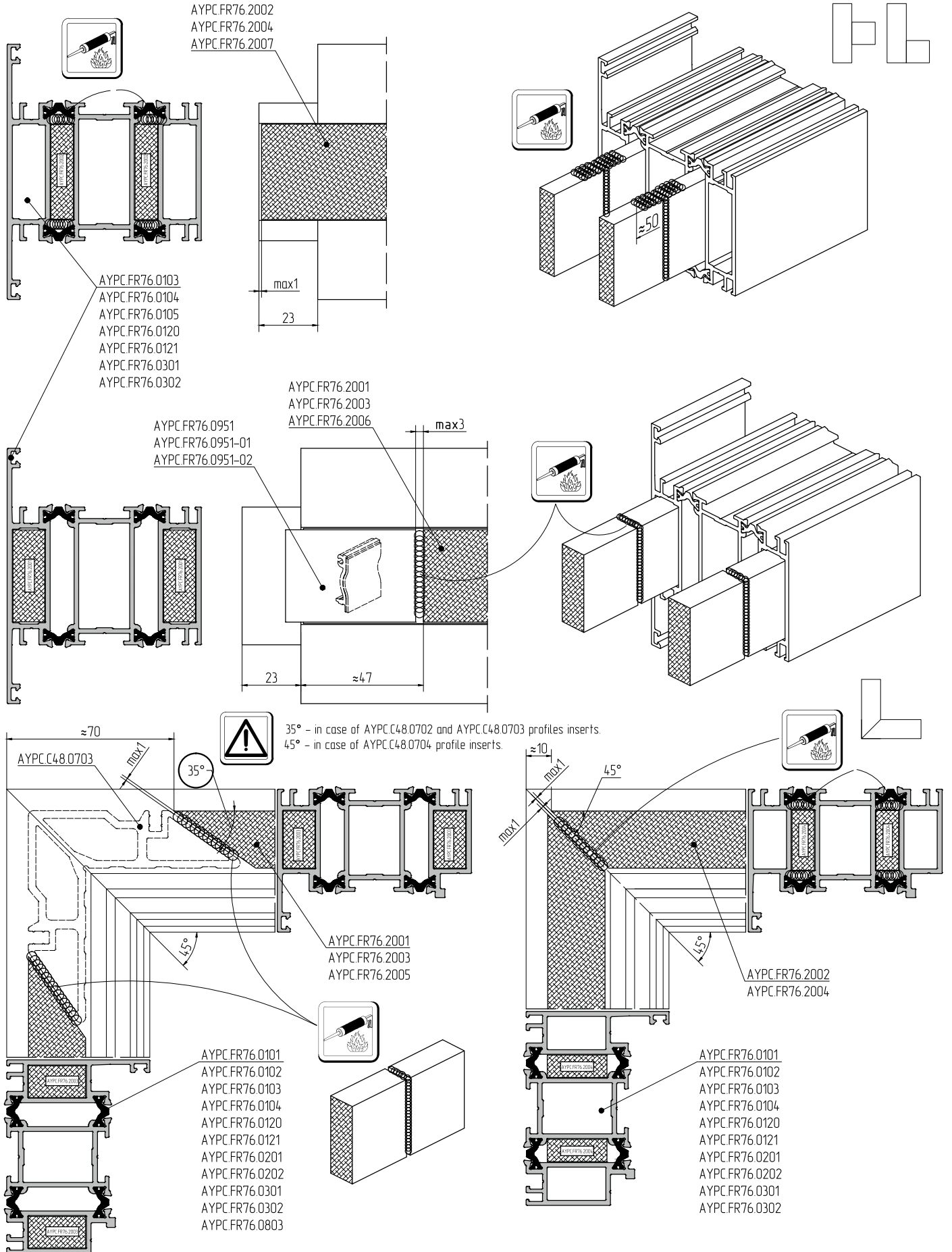
Scheme of machining and assemblage of the lower system part with automatic threshold



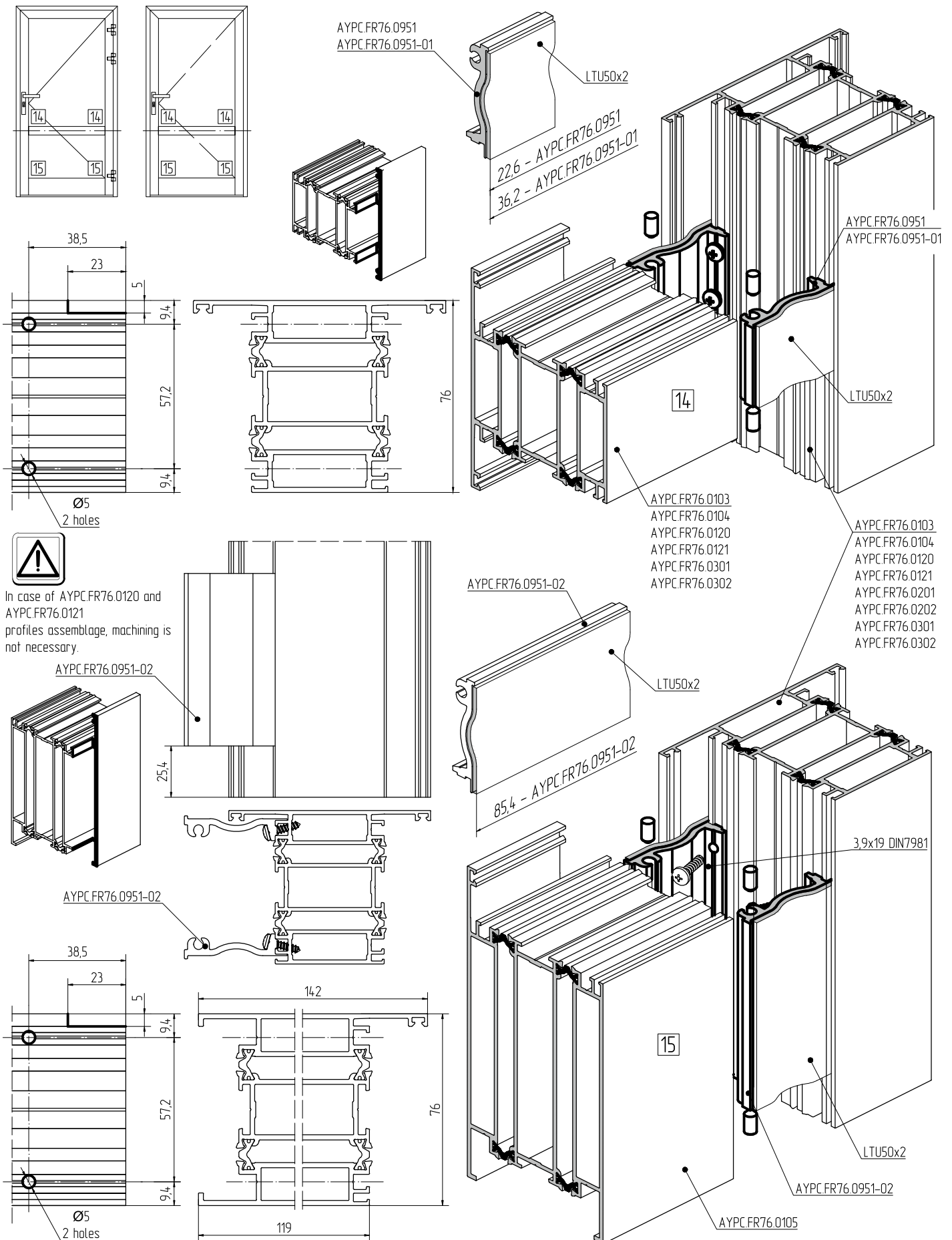
Scheme of machining and assemblage of the lower system part automatic threshold



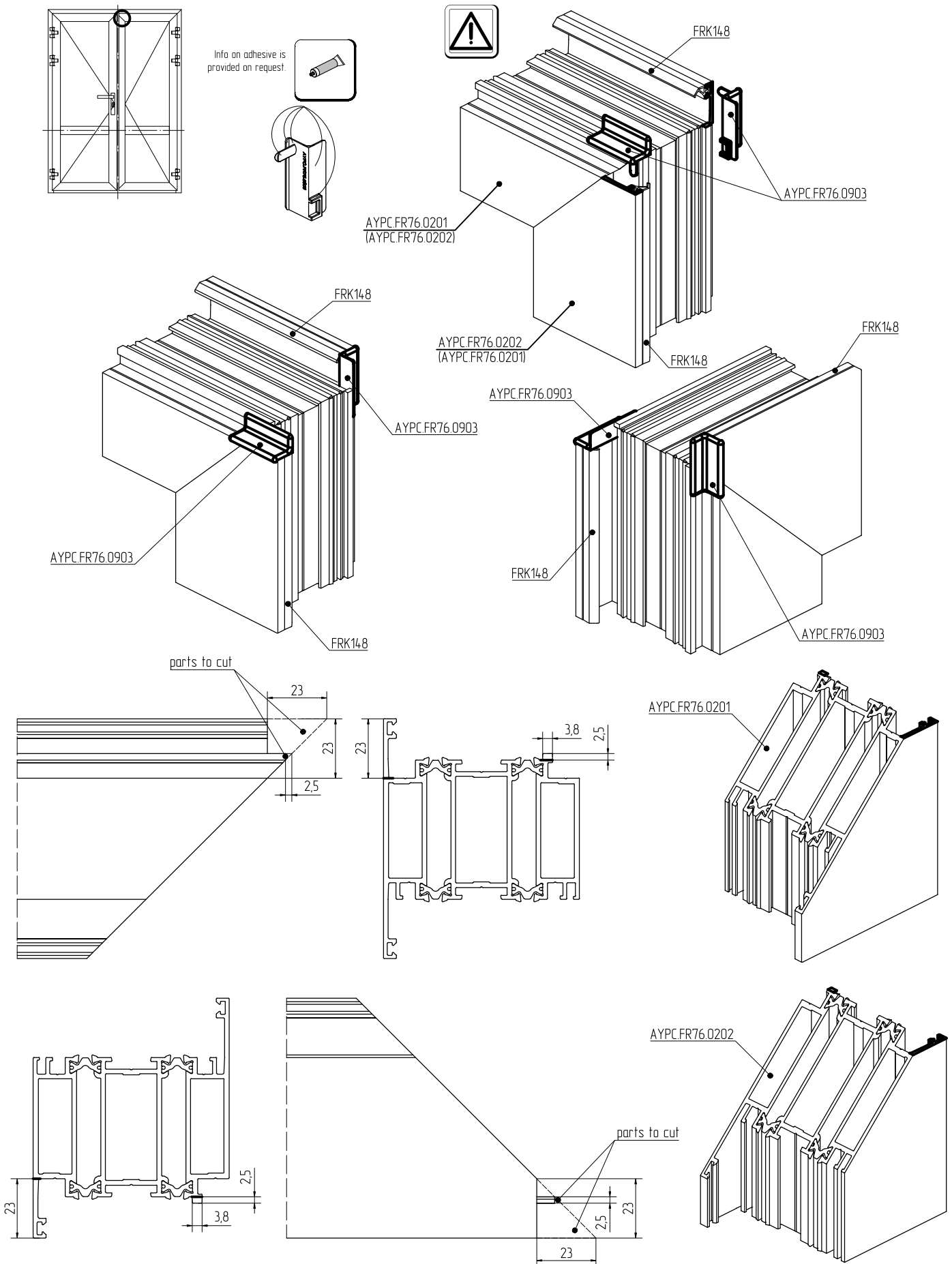
Scheme of fireproof inserts installation



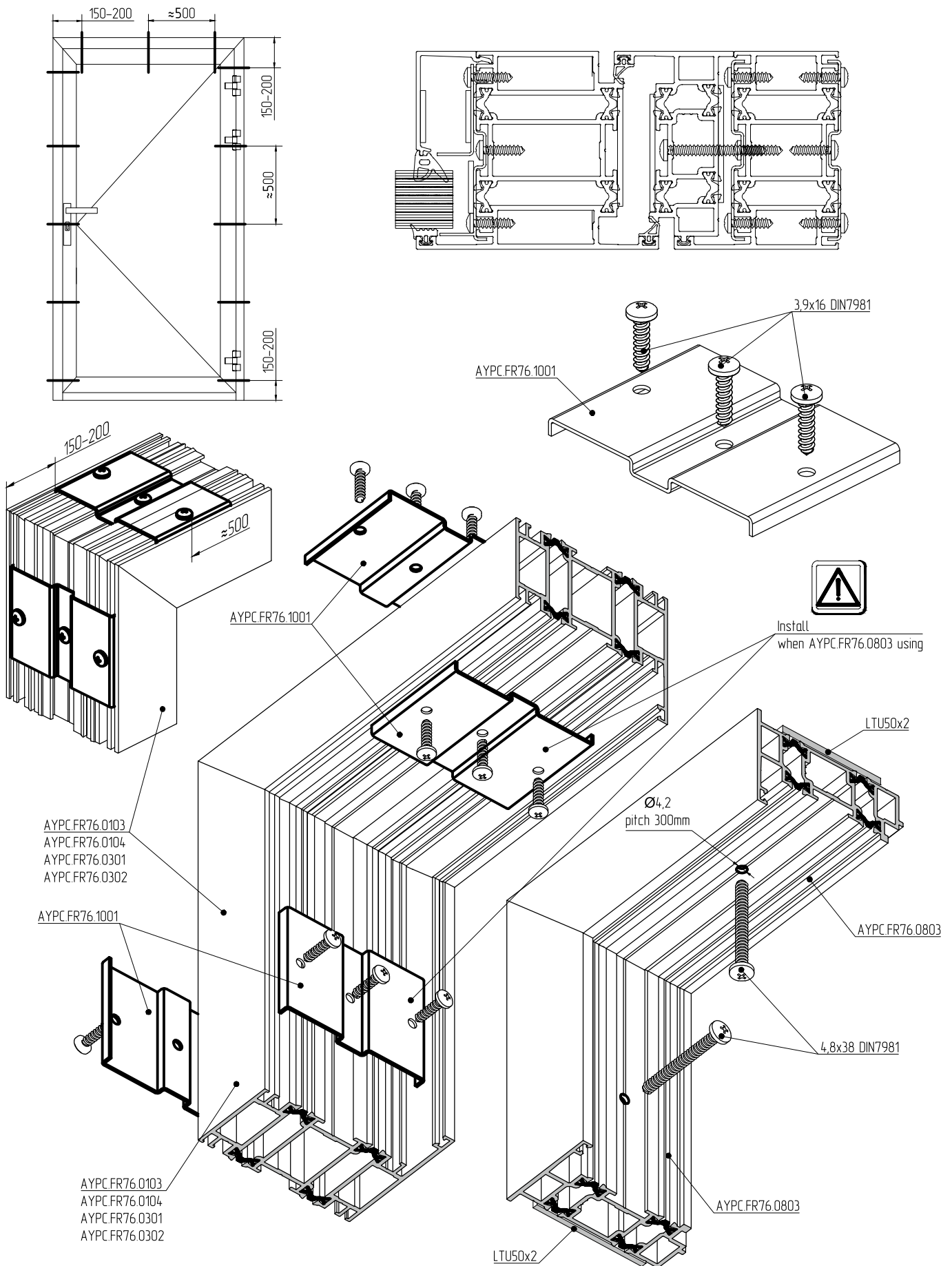
Scheme of assemblage and machining of T-junction profiles



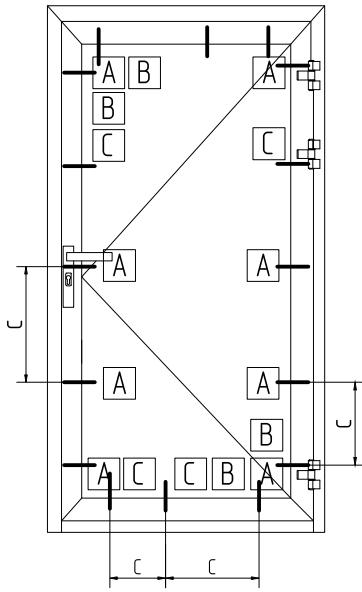
Scheme of assemblage and machining of T/Z-junction door leaf profiles



Scheme of assemblage and machining of profiles together with AYPC.FR76.0803 profile

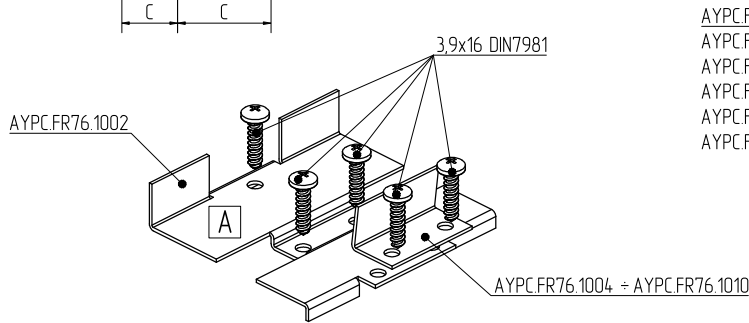
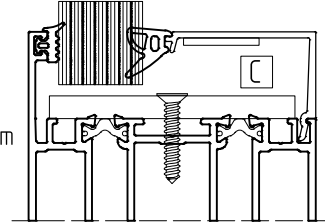
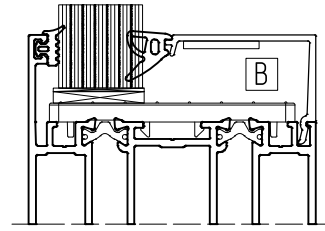
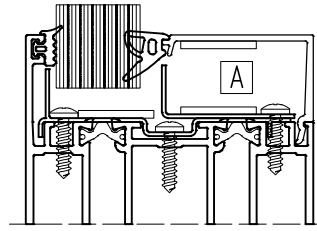


Scheme of horizontal glass beads installation

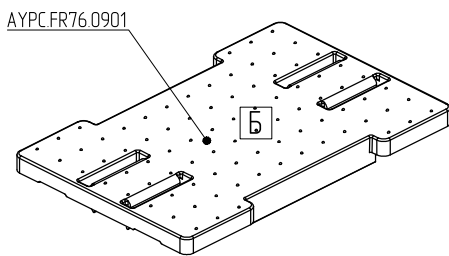


C- not more than 300mm for EIW60.
C- not more than 500mm for EIW30 and EIW45.

For EIW60, in case of door leaf dimensions of up to 660mm
AYPC.FR76.0901 is not used.
Infill unit wedging is made with AYPC.FR76.0902.



- AYPC.FR76.0103
- AYPC.FR76.0104
- AYPC.FR76.0201
- AYPC.FR76.0202
- AYPC.FR76.0301
- AYPC.FR76.0302



AYPC.FR76.0901

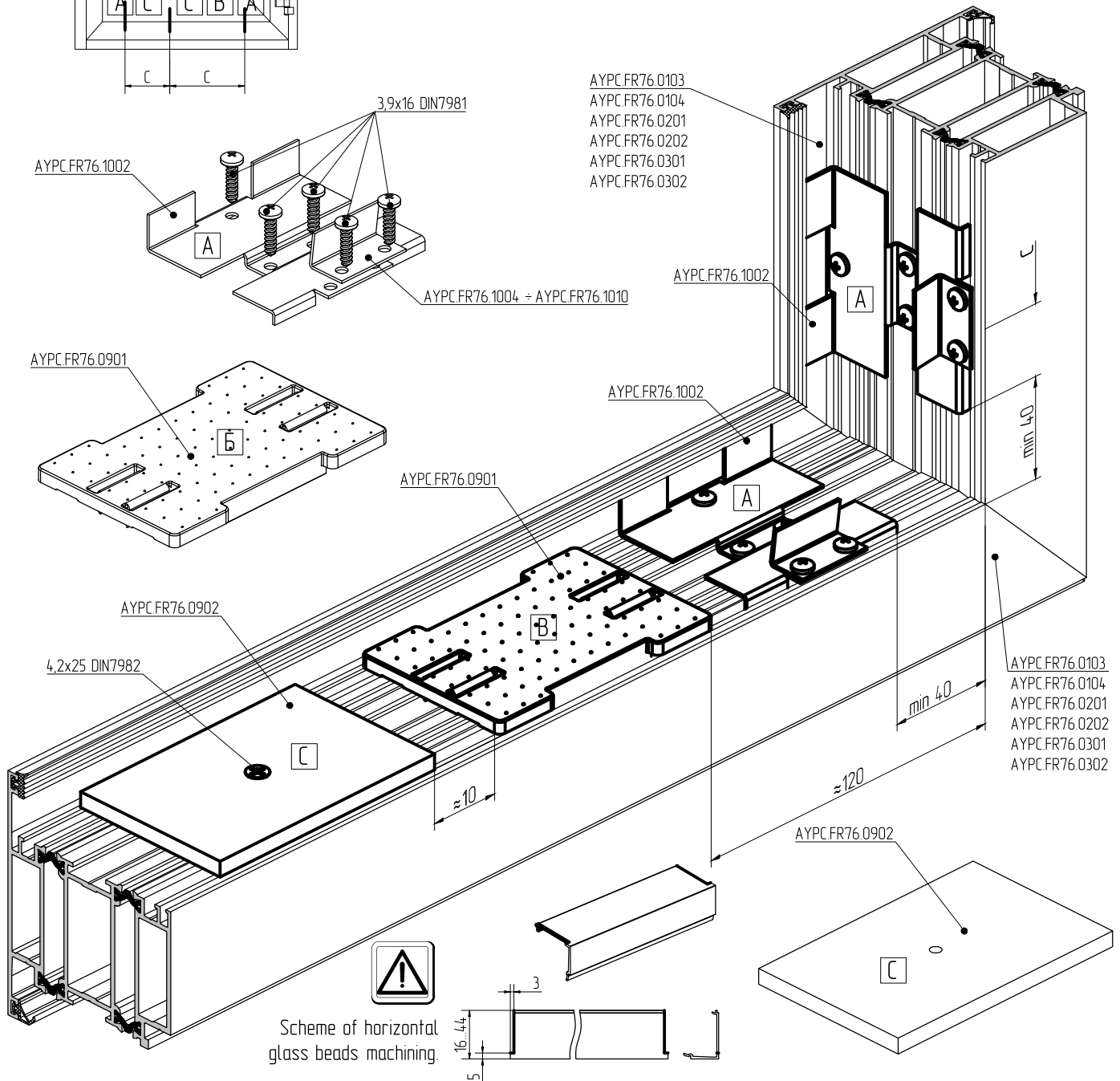
AYPC.FR76.1002

AYPC.FR76.0902

4.2x25 DIN7982

AYPC.FR76.0902

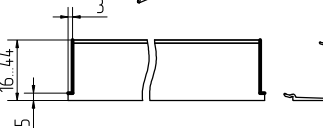
≈ 10



- AYPC.FR76.0103
- AYPC.FR76.0104
- AYPC.FR76.0201
- AYPC.FR76.0202
- AYPC.FR76.0301
- AYPC.FR76.0302

AYPC.FR76.0902

Scheme of horizontal
glass beads machining.

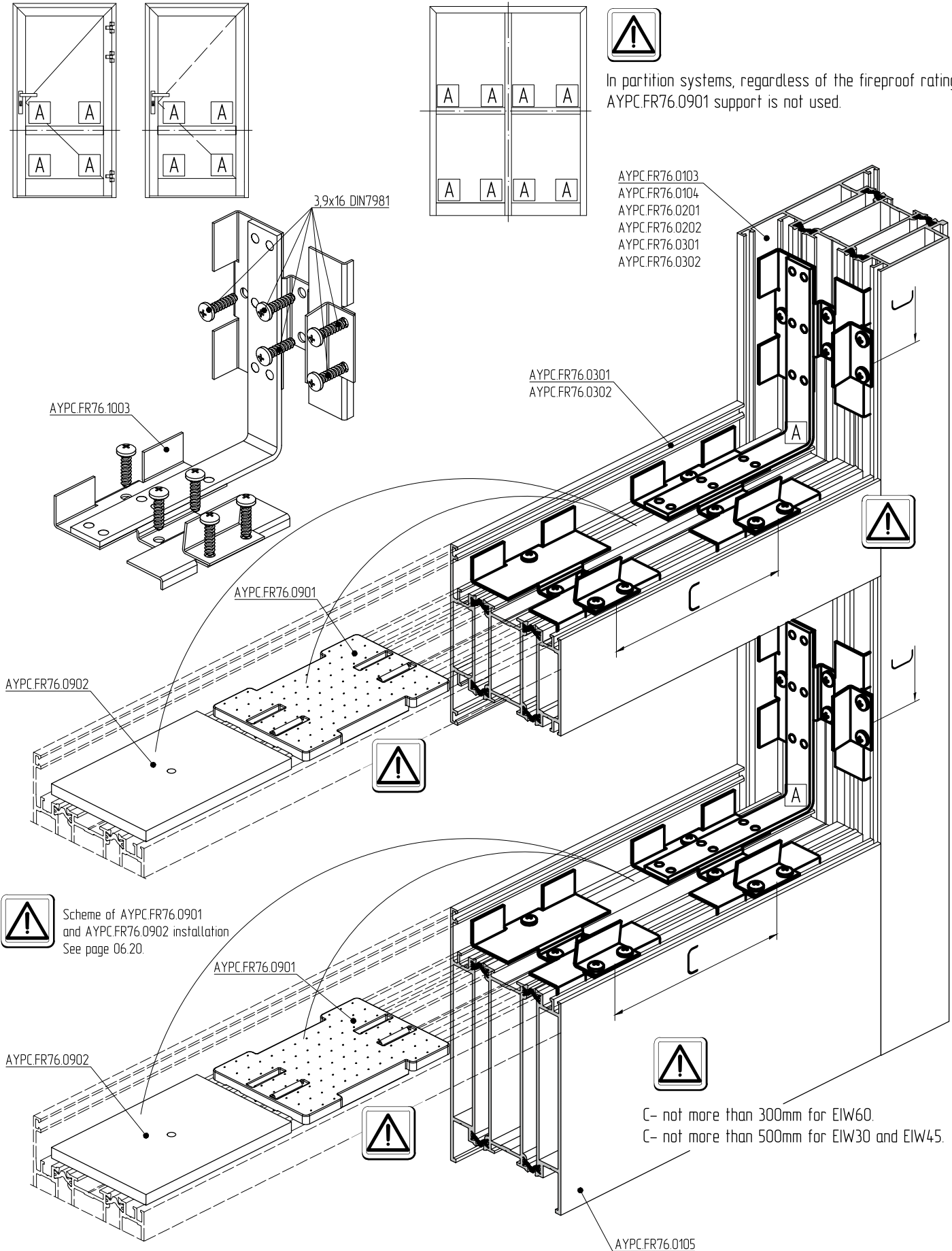


Scheme of steel holders installation



In partition systems, regardless of the fireproof rating AYPc.FR76.0901 support is not used.

- AYPC.FR76.0103
- AYPC.FR76.0104
- AYPC.FR76.0201
- AYPC.FR76.0202
- AYPC.FR76.0301
- AYPC.FR76.0302

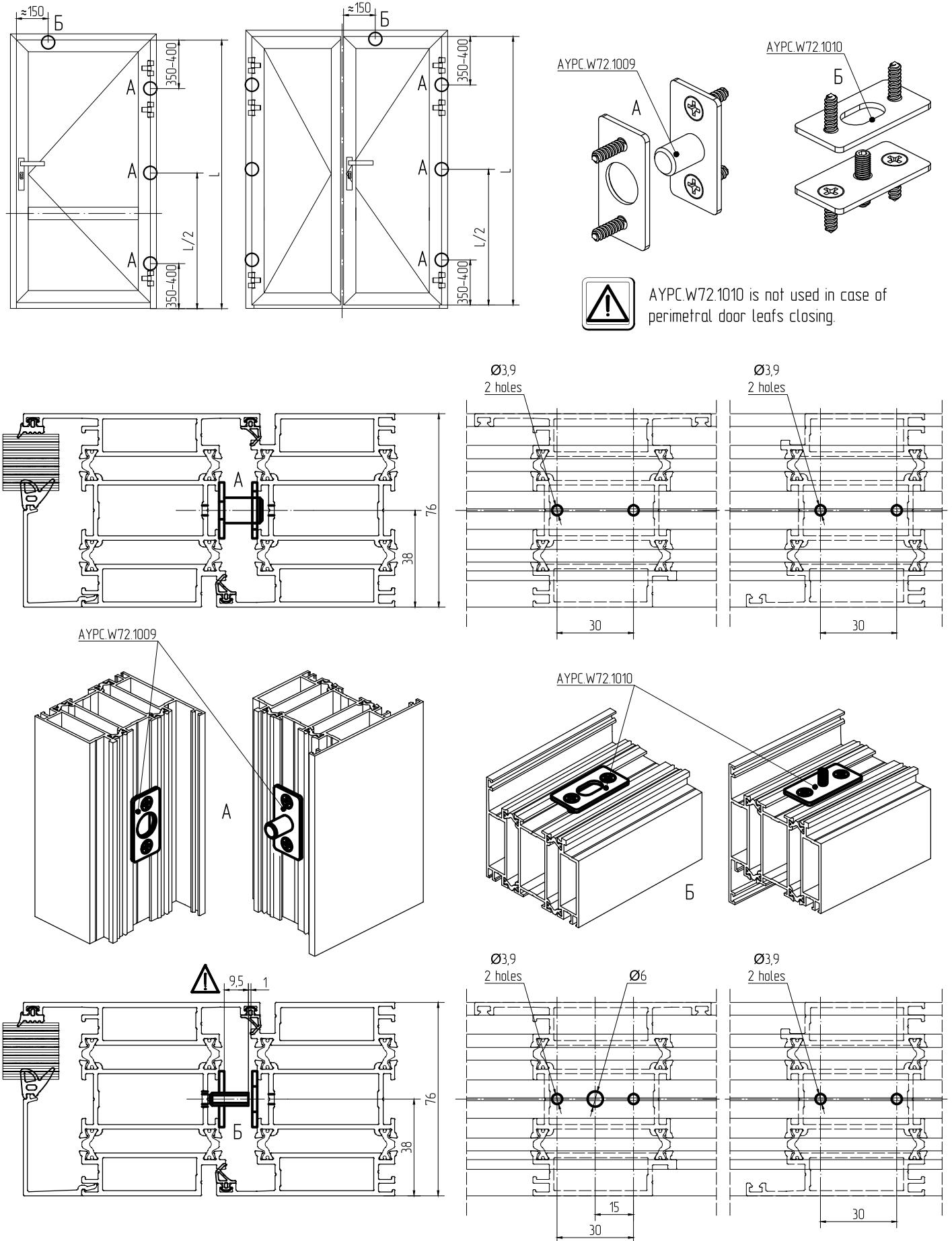


Scheme of AYPc.FR76.0901 and AYPc.FR76.0902 installation
See page 06.20.

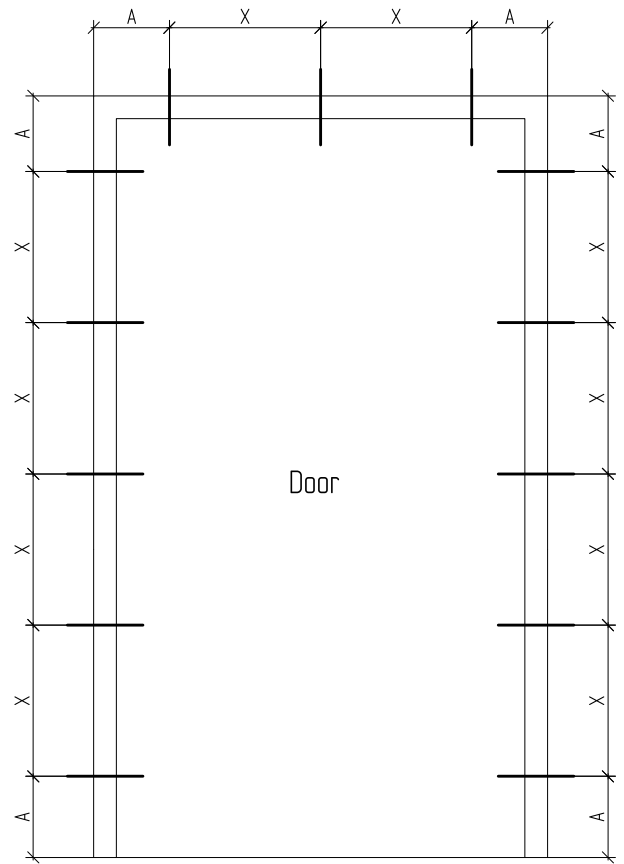
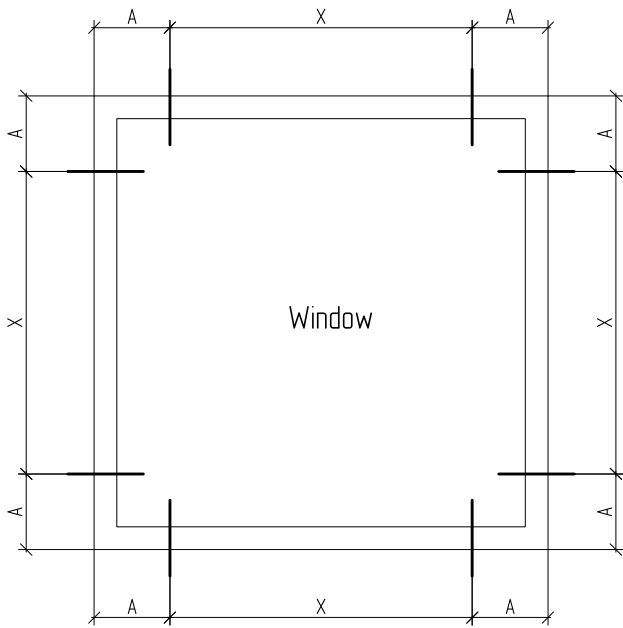


C- not more than 300mm for EIW60.
C- not more than 500mm for EIW30 and EIW45.

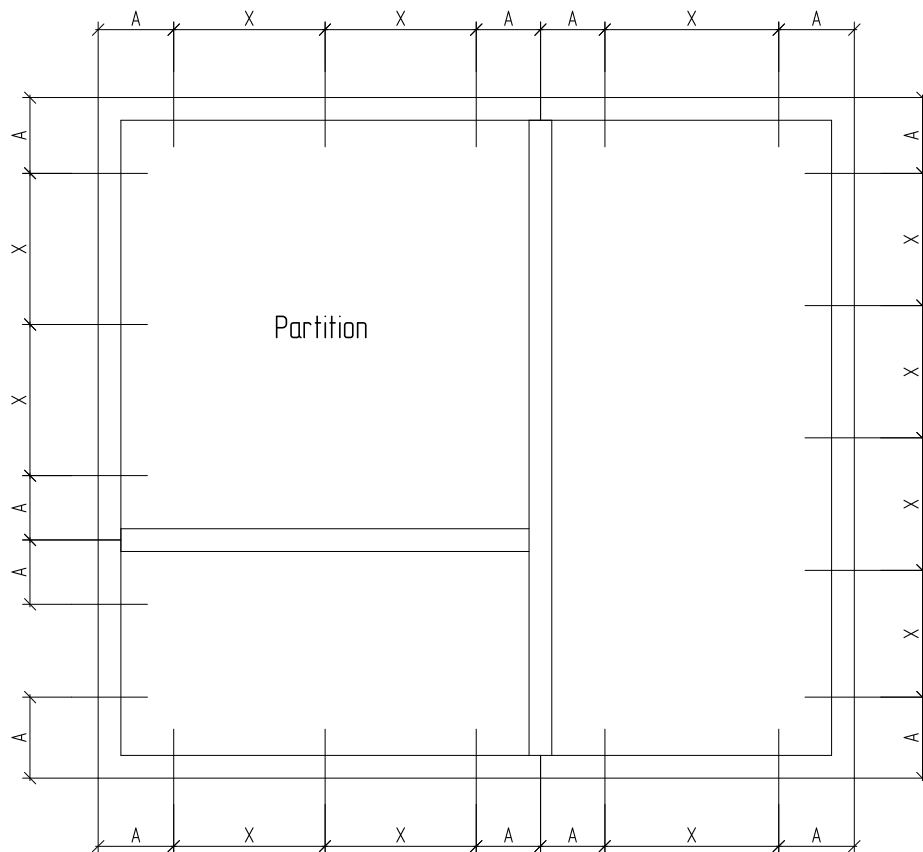
Scheme of AYPC.W72.1009 and AYPC.W72.1010 fireproof inserts kits installation



Scheme of fastening elements placement



$X \leq 700 \text{ mm}$
 $A = 200 \text{ mm}$



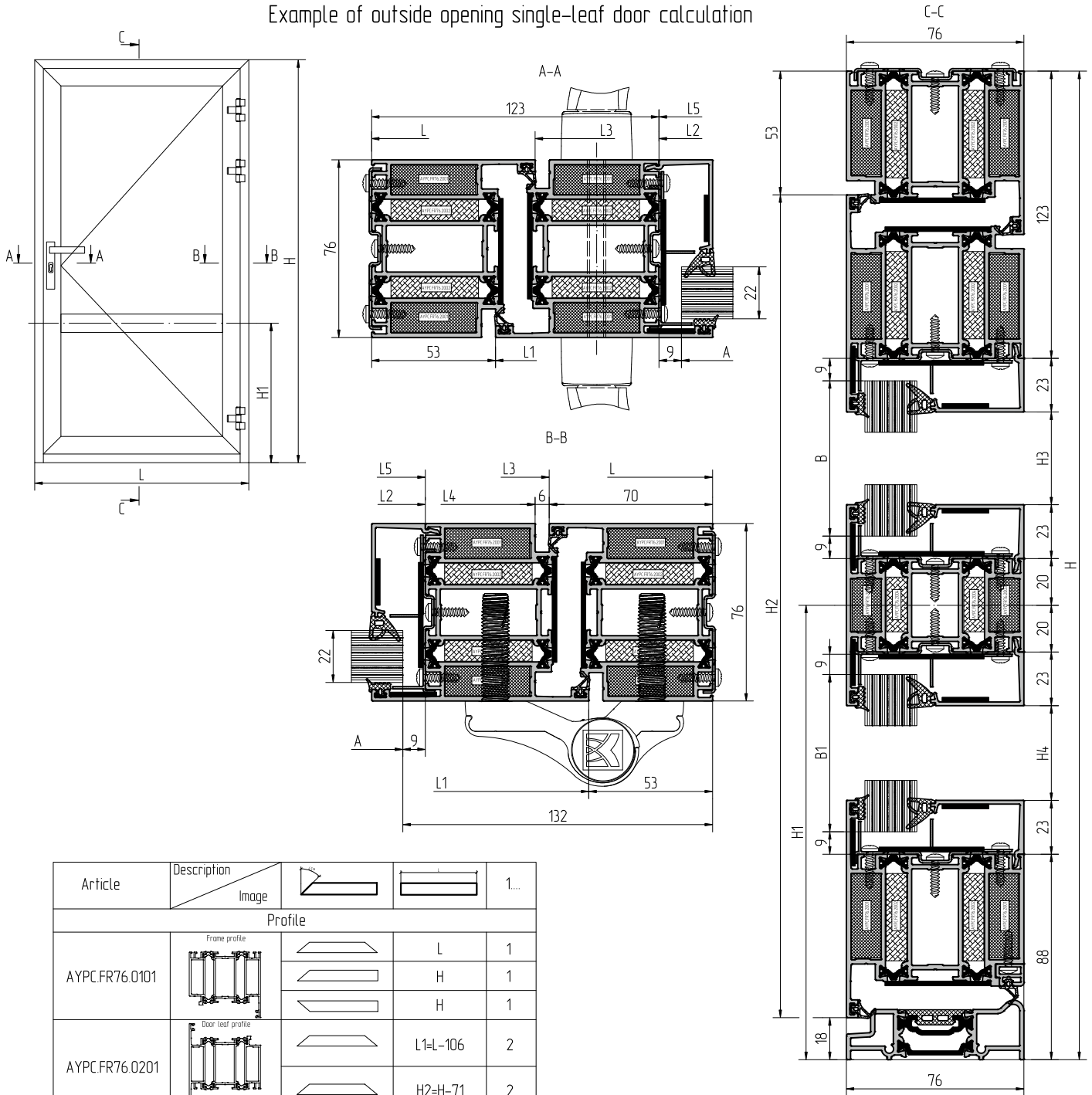


ALT FR76
FIRE RESISTANT
DOORS WITH DOUBLE
THERMAL BREAK

EXAMPLE OF STANDARD SYSTEM CALCULATION

07

Example of outside opening single-leaf door calculation



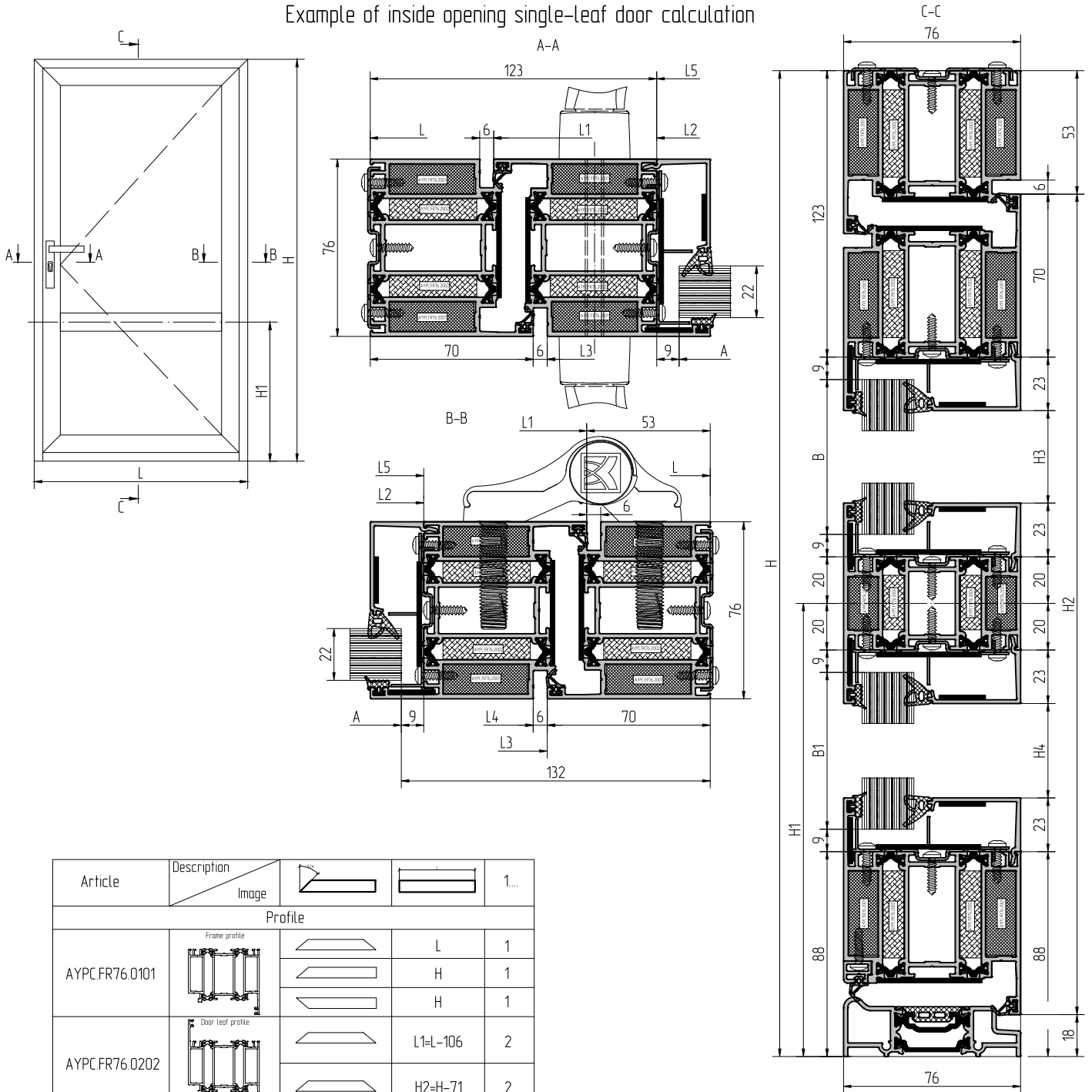
Article	Description	Image	Image	1....
Profile				
AYPC.FR76.0101	Frame profile		L	1
			H	1
			H	1
AYPC.FR76.0201	Door leaf profile		L1=L-106	2
			H2=H-71	2
AYPC.FR76.0301	Transom bar profile		L2=L-247	1
AYPC.FR76.0801	Threshold profile		L3=L-140	1
AYPC.FR76.0614	Door adjoining profile		L4=L1-46	1
AYPC.FR76.0608	Glass bead profile		* L5=L2	4
			H3=H-H1-189	2
			H4=H1-154	2

Fireproof infill unit	
A=L-264, B=H-H1-161	1
A=L-264, B1=H1-126	1



Articles of glass bead profiles and rubber gaskets should be selected depending on glass thickness (See chapter 04 - Table of glazing).
Glass bead profiles* should be machined (See chapter 06 - Machining and assemblage of profiles, page 06.20).

Example of inside opening single-leaf door calculation



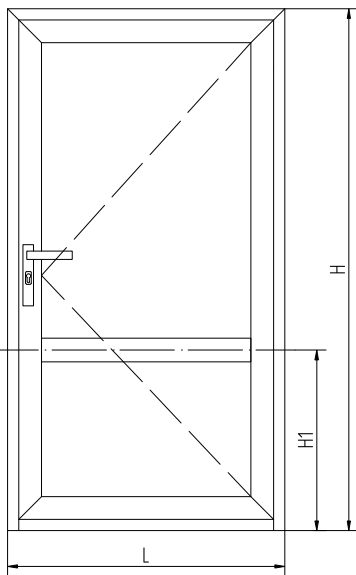
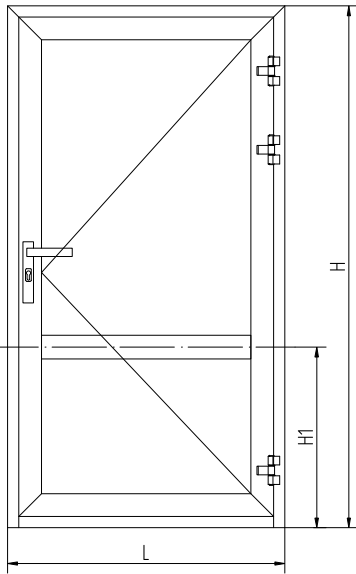
Article	Description	Image	1...
Profile			
AYPC.FR76.0101	Frame profile		L 1
			H 1
			H 1
AYPC.FR76.0202	Door leaf profile		L1=L-106 2
			H2=H-71 2
AYPC.FR76.0301	Transom bar profile		L2=L-246 1
AYPC.FR76.0801	Threshold profile		L3=L-140 1
AYPC.FR76.0614	Door adjoining profile		L4=L1-46 1
AYPC.FR76.0608	Glass bead profile		* L5=L2 4
			H3=H-H1-189 2
			H4=H1-154 2

Fireproof infill unit	
A=L-264, B=H-H1-161	1
A=L-264, B1=H1-126	1



Articles of glass bead profiles and rubber gaskets should be selected depending on glass thickness (See chapter 04 - Table of glazing).
Glass bead profiles* should be machined (See chapter 06 - Machining and assemblage of profiles, page. 06.20).

Example of outside/inside opening single-leaf door calculation

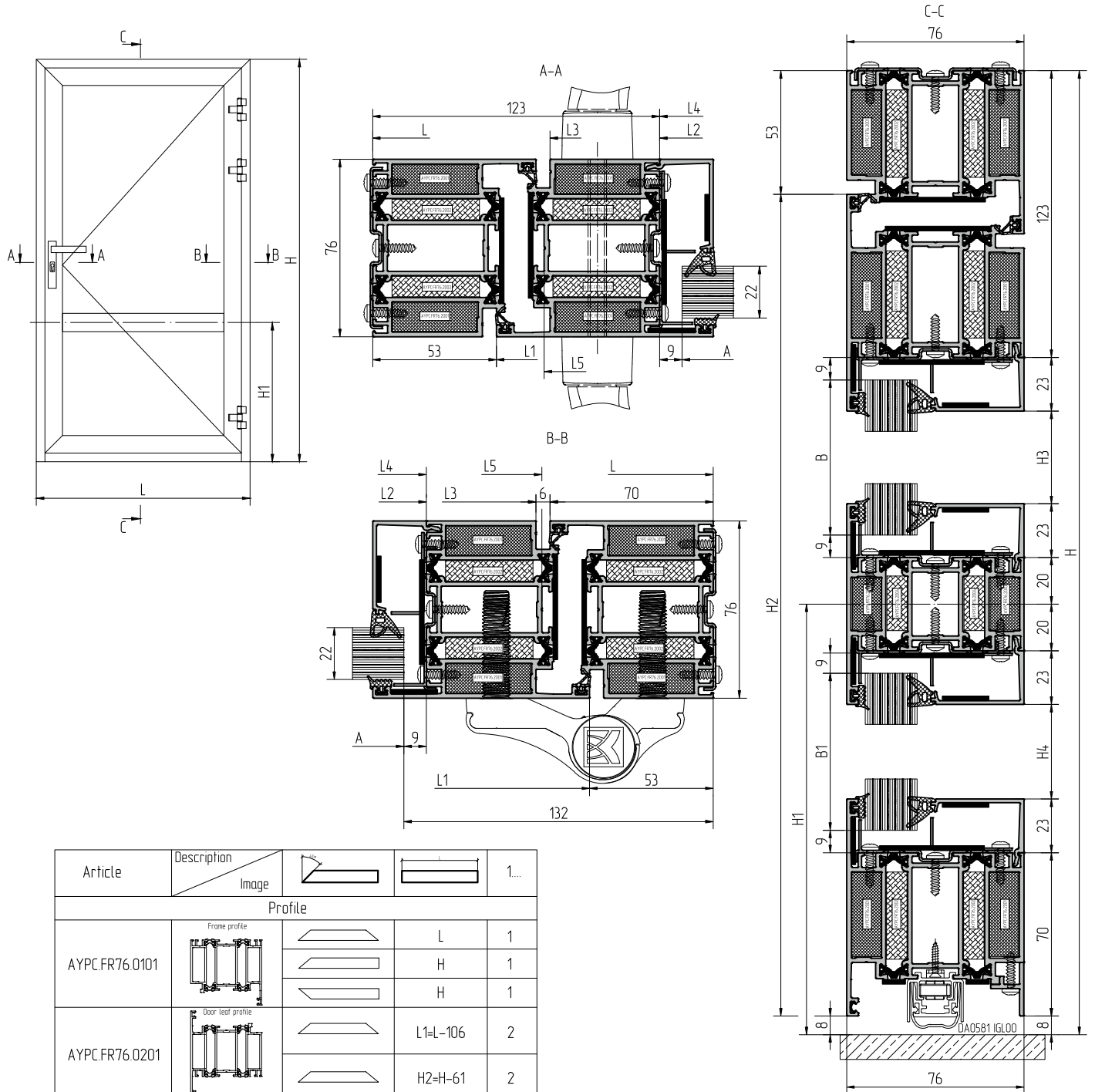


Article	Description	Image		1...
Components				
AYPC.FR76.1001	Steel holder		$FS1=(L+Hx2)/500$	
AYPC.FR76.1002	Steel holder		$FS2=(L1x2+H2x2+L2x2)/300$	
AYPC.FR76.1003	Clamping corner			2
AYPC.FR76.1010	Steel holder		$FS10=(L1x2+H2x2+L2x2)/300$	
AYPC.W72.1009	Fireproof insert kit			3
* AYPC.W72.1010	Upper fireproof insert kit			1
* LTU10x2	Thermal sealing tape		$L1x4+H2x2$	
* LTU50x2	Thermal sealing tape		$L+Hx2+H2+(A+B)x2+(A+B1)x2$	
LTU20x2	Thermal sealing tape		$(A+B)x2+(A+B1)x2+L5x4+(H3+H4)x2$	
LTU50x2	Thermal sealing tape		$L+Hx2+L1x2+H2x2+(A+B)x2+(A+B1)x2$	
AYPC.FR76.2001	Fireproof insert		$Lx2+Hx4+L1x4+H2x4$	
AYPC.FR76.2002	Fireproof insert		$Lx2+Hx4+L1x4+H2x4$	
AYPC.FR76.2003	Fireproof insert		$L2x2$	
AYPC.FR76.2004	Fireproof insert		$L2x2$	
FRK29-01	Rubber gasket		$(A+B)x2+(A+B1)x2$	
FRK67	Rubber gasket		$(A+B)x2+(A+B1)x2$	
FRK148	Rubber gasket		$L+Hx2+L1x3+H2x2+L4$	
FRK155	Rubber gasket		$L3$	
AYPC.FR76.0902	Wooden support			4
AYPC.FR76.0901	Bearing support			8
100x26x1	Leveling support			8
100x26x3	Leveling support			8
AYPC.FR76.0908	Threshold plug			1
AYPC.FR76.0908-01	Threshold plug			1
AYPC.FR76.0909	Threshold plug			1
AYPC.FR76.0909-01	Threshold plug			1
AYPC.FR76.0912	Door adjoining profile collar			1
AYPC.FR76.0912-01	Door adjoining profile collar			1
0715	Clamping corner			10
AYPC.FR76.0955	Clamping corner			12
AYPC.FR76.0951	Transom fixing element			4
3,9x16 DIN7981	Self-tapping screw		$FS1x3+FS2x5+40$	
3,9x16 DIN7981	Self-tapping screw		$L4/250$	
4,2x19 DIN7981	Self-tapping screw			4
4,2x25 DIN7982	Self-tapping screw			8



* Calculation of LTU10x2 and LTU50x2 is given for perimetral door leaf locking.
 LTU50x2 is used for all types of closing on the hinges side of door leaf.
 * AYPC.W72.1010 is not used in case of perimetral door leaf locking.

Example of calculation of outside opening single-leaf door with automatic threshold



Article	Description	Image	1...
Profile			
AYPC.FR76.0101	Frame profile		L 1
			H 1
			H 1
AYPC.FR76.0201	Door leaf profile		L1=L-106 2
			H2=H-61 2
AYPC.FR76.0301	Transom bar profile		L2=L-247 1
AYPC.FR76.0613	Door adjoining profile		L3=L1-50 1
AYPC.FR76.0608	Glass bead profile		* L4=L2 4
			H3=H-H1-189 2
			H4=H1-144 2

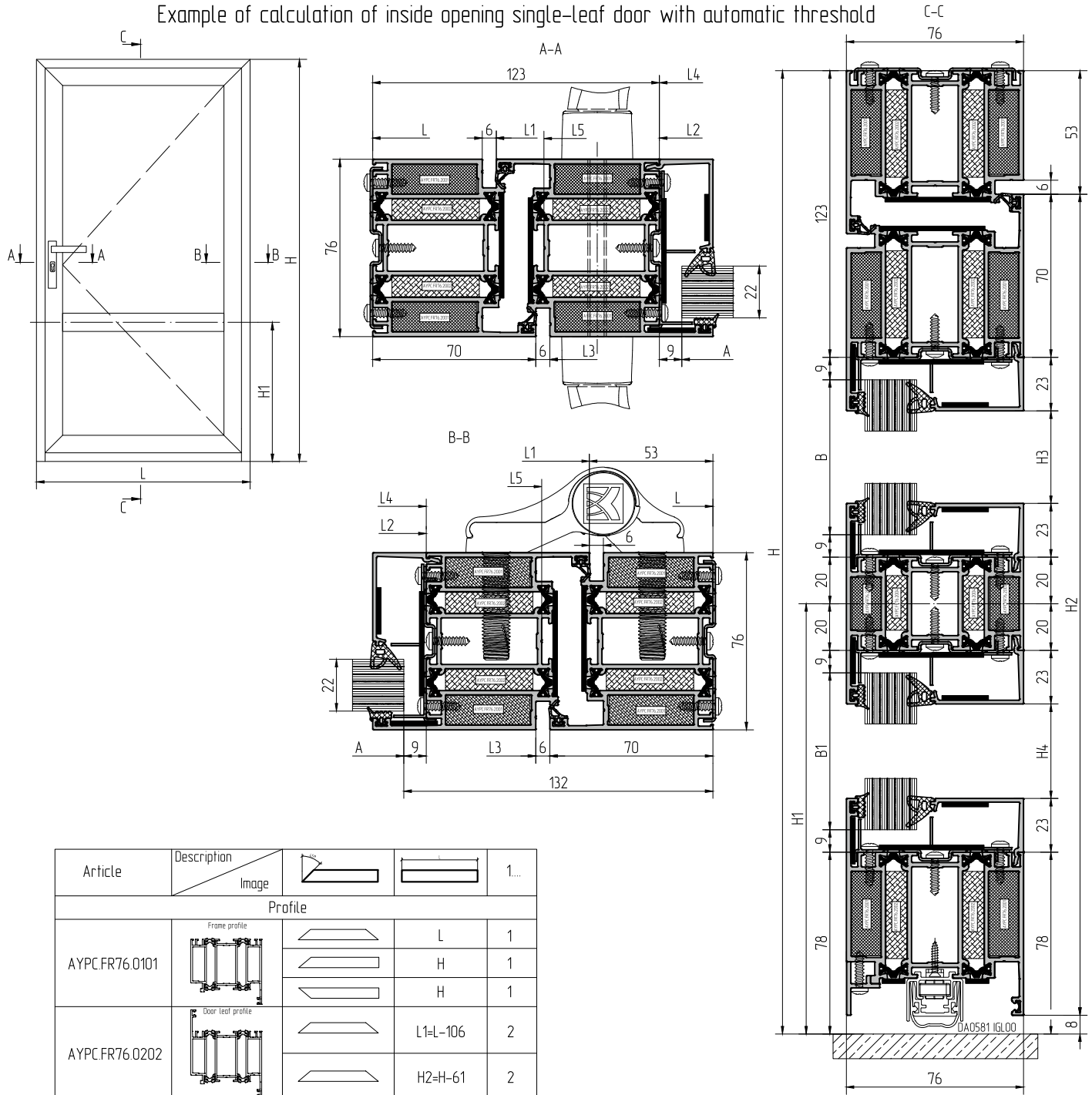
Fireproof infill unit	
A=L-264, B=H-H1-161	1
A=L-264, B1=H1-116	1

DA0581 IGL00 Threshold	
L5=L1-32	1



Articles of glass bead profiles and rubber gaskets should be selected depending on glass thickness (See chapter 04 - Table of glazing).
Glass bead profiles* should be machined (See chapter 06 - Machining and assemblage of profiles, page 06.20).

Example of calculation of inside opening single-leaf door with automatic threshold



Article	Description	Image	Profile	1...
Profile				
AYPC.FR76.0101	Frame profile		L	1
			H	1
			H	1
AYPC.FR76.0202	Door leaf profile		L1=L-106	2
			H2=H-61	2
AYPC.FR76.0301	Transom bar profile		L2=L-247	1
AYPC.FR76.0613	Door adjoining profile		L3=L1-50	1
AYPC.FR76.0608	Glass bead profile		* L4=L2	4
			H3=H-H1-189	2
			H4=H1-144	2

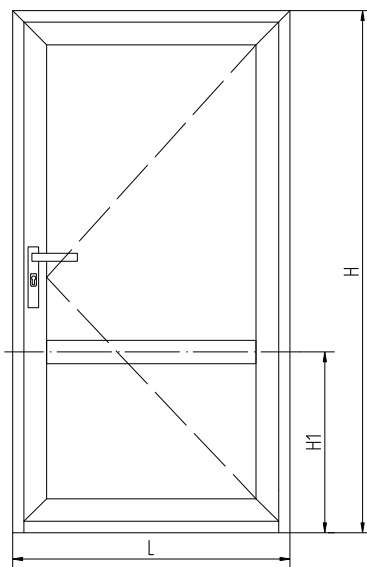
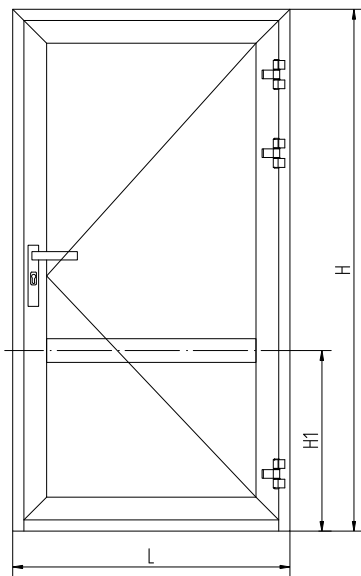
Fireproof infill unit		
A=L-264, B=H-H1-161		1
A=L-264, B1=H1-116		1

DA0581 IGL00 Threshold		
L5=L1-32		1



Articles of glass bead profiles and rubber gaskets should be selected depending on glass thickness (See chapter 04 - Table of glazing).
Glass bead profiles* should be machined (See chapter 06 - Machining and assemblage of profiles, page 06.20).

Example of calculation of outside/inside opening single-leaf door with automatic threshold

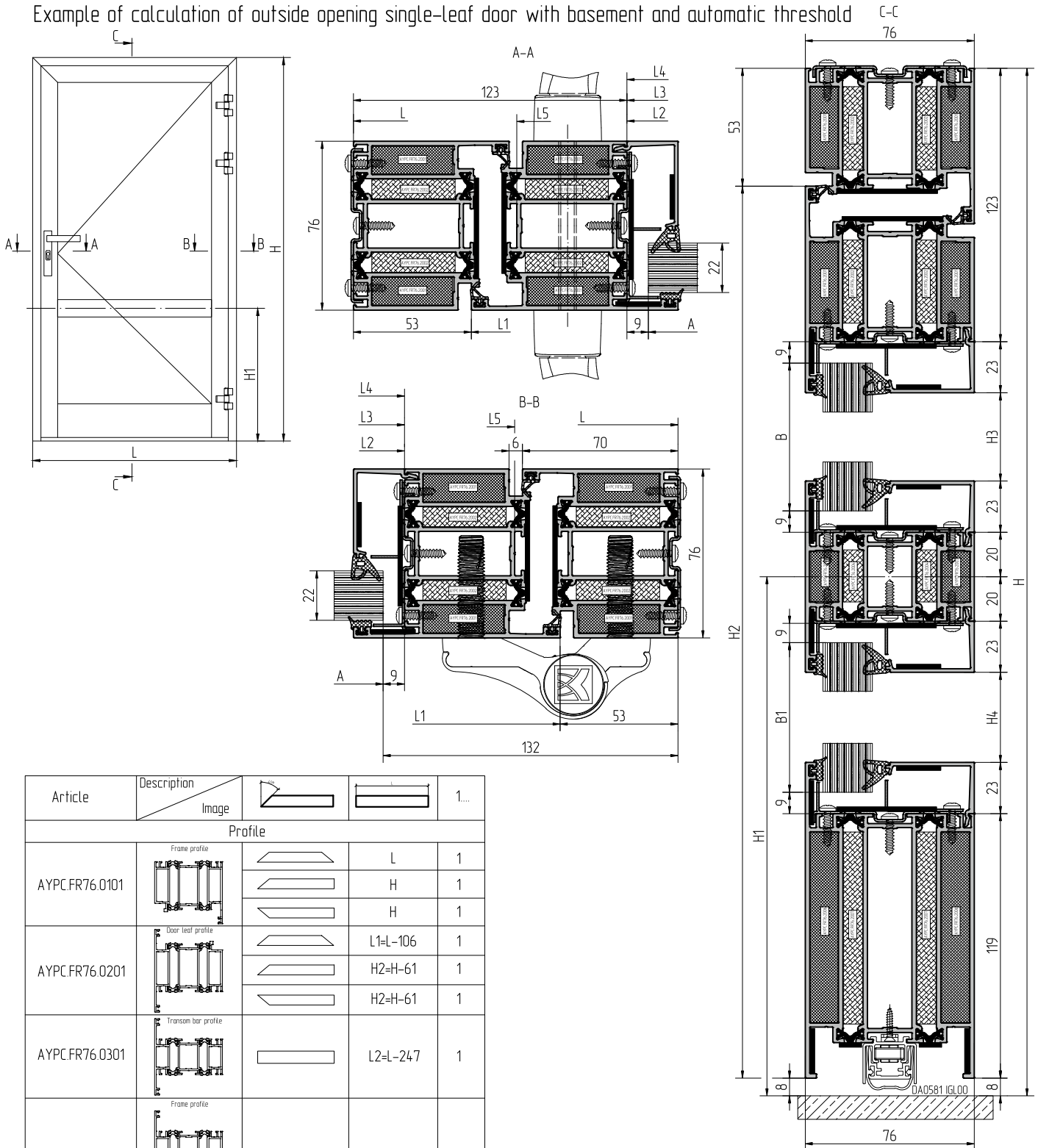


Article	Description	Image		1...
Components				
AYPC.FR76.1001	Steel holder		$FS1=(L+Hx2)/500$	
AYPC.FR76.1002	Steel holder		$FS2=(L1x2+H2x2+L2x2)/300$	
AYPC.FR76.1003	Clamping corner			2
AYPC.FR76.1010	Steel holder		$FS10=(L1x2+H2x2+L2x2)/300$	
AYPC.W72.1009	Fireproof insert kit			3
* AYPC.W72.1010	Upper fireproof insert kit			1
* LTU10x2	Thermal sealing tape		$L1x4+H2x2$	
* LTU50x2	Thermal sealing tape		$L+Hx2+H2+(A+B)x2+(A+B1)x2$	
LTU10x2	Thermal sealing tape		$L1x2$	
LTU20x2	Thermal sealing tape		$(A+B)x2+(A+B1)x2+L4x4+(H3+H4)x2$	
LTU50x2	Thermal sealing tape		$L+Hx2+L1+H2x2+(A+B)x2+(A+B1)x2$	
AYPC.FR76.2001	Fireproof insert		$Lx2+Hx4+L1x4+H2x4$	
AYPC.FR76.2002	Fireproof insert		$Lx2+Hx4+L1x4+H2x4$	
AYPC.FR76.2003	Fireproof insert		$L2x2$	
AYPC.FR76.2004	Fireproof insert		$L2x2$	
FRK29-01	Rubber gasket		$(A+B)x2+(A+B1)x2$	
FRK67	Rubber gasket		$(A+B)x2+(A+B1)x2$	
FRK148	Rubber gasket		$L+Hx2+L1+H2x2$	
AYPC.FR76.0902	Wooden support			4
AYPC.FR76.0901	Bearing support			8
100x26x1	Leveling support			8
100x26x3	Leveling support			8
AYPC.FR76.0905	Threshold plug			1
AYPC.FR76.0906	Door adjoining profile collar			2
AYPC.FR76.0913	Door adjoining profile plug			1
AYPC.FR76.0913-01	Door adjoining profile plug			1
0715	Clamping corner			10
AYPC.FR76.0955	Clamping corner			12
AYPC.FR76.0951	Transom fixing element			4
3,9x16 DIN7981	Self-tapping screw		$FS1x3+FS2x5+40$	
3,9x16 DIN7981	Self-tapping screw		$L3/250$	
4,2x25 DIN7982	Self-tapping screw			4
3,9x22 DIN7982	Self-tapping screw			2



* Calculation of LTU10x2 and LTU50x2 is given for perimeteral door leaf locking.
 LTU50x2 is used for all types of closing on the hinges side of door leaf.
 * AYPC.W72.1010 is not used in case of perimeteral door leaf locking.

Example of calculation of outside opening single-leaf door with basement and automatic threshold



Article	Description	Image	1...
Profile			
AYPC.FR76.0101	Frame profile		L 1
			H 1
			H 1
AYPC.FR76.0201	Door leaf profile		L1=L-106 1
			H2=H-61 1
			H2=H-61 1
AYPC.FR76.0301	Transom bar profile		L2=L-247 1
AYPC.FR76.0105	Frame profile		L3=L2 1
AYPC.FR76.0608	Glass bead profile		* L4=L2 4
			H3=H-H1-189 2
			H4=H1-193 2

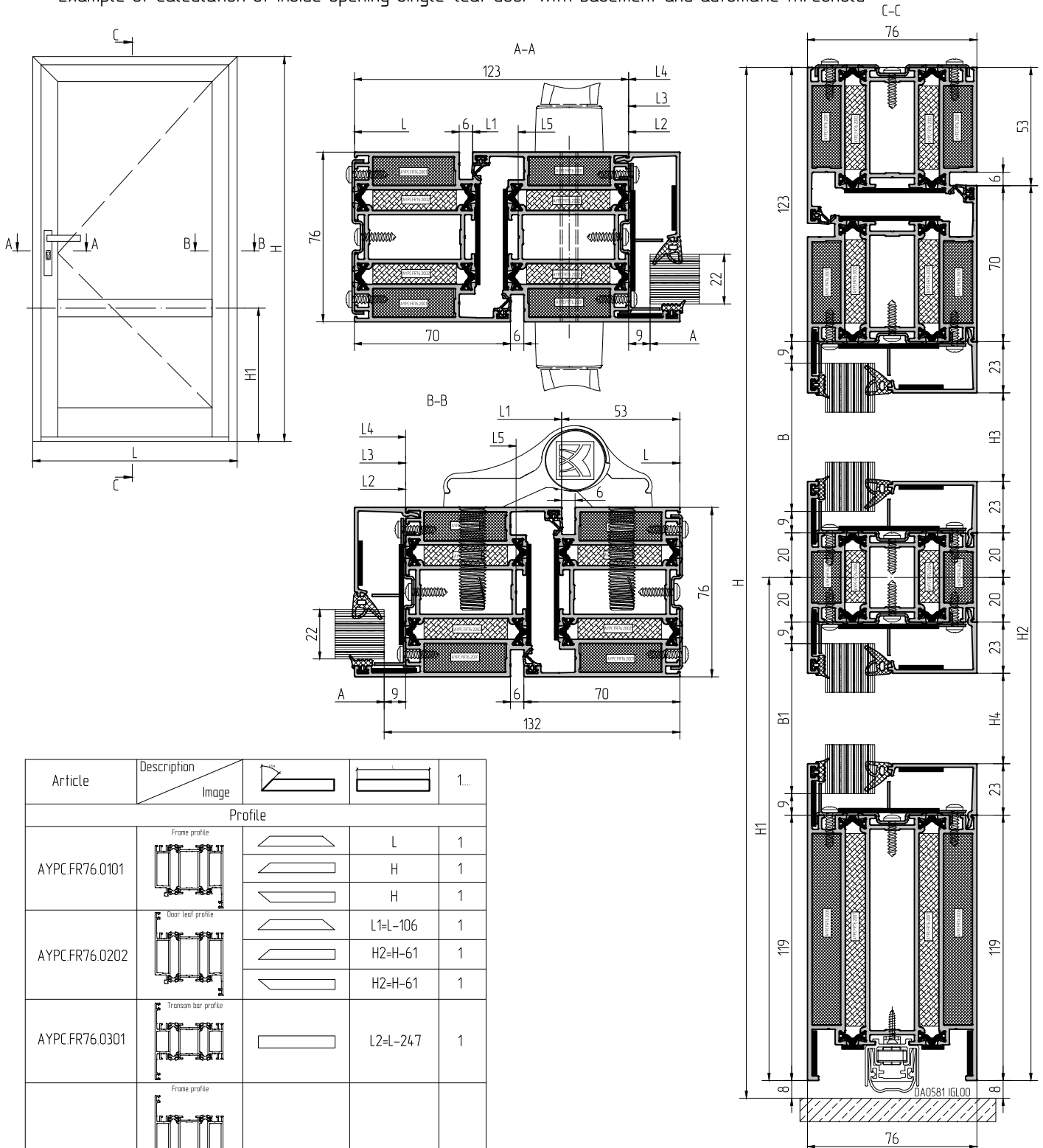
Fireproof infill unit	
A=L-264, B=H-H1-161	1
A=L-264, B1=H1-165	1

Threshold DA0581 IGL00	
L5=L1-32	1



Articles of glass bead profiles and rubber gaskets should be selected depending on glass thickness (See chapter 04 - Table of glazing).
Glass bead profiles* should be machined (See chapter 06 - Machining and assemblage of profiles, page 06.20).

Example of calculation of inside opening single-leaf door with basement and automatic threshold



Article	Description	Image		1..	
Profile					
AYPC.FR76.0101	Frame profile			L	1
				H	1
				H	1
AYPC.FR76.0202	Door leaf profile			L1=L-106	1
				H2=H-61	1
				H2=H-61	1
AYPC.FR76.0301	Transom bar profile			L2=L-247	1
AYPC.FR76.0105	Frame profile			L3=L2	1
AYPC.FR76.0608	Glass bead profile			* L4=L2	4
				H3=H-H1-189	2
				H4=H1-193	2

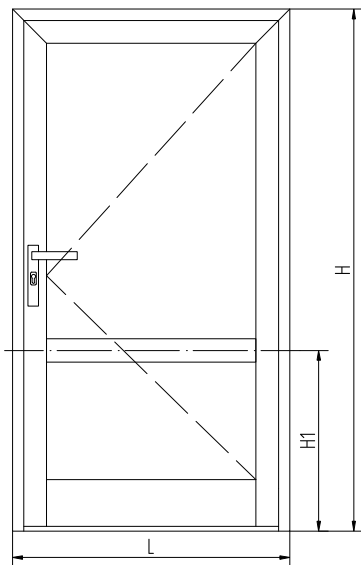
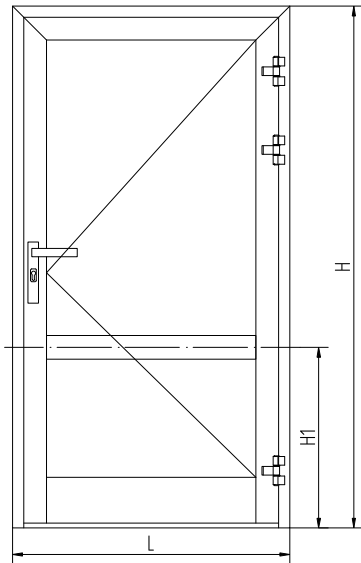
Fireproof infill unit	
A=L-264, B=H-H1-161	1
A=L-264, B1=H1-165	1

Threshold DA0581 IGL00	
L5=L1-32	1



Articles of glass bead profiles and rubber gaskets should be selected depending on glass thickness (See chapter 04 - Table of glazing).
Glass bead profiles* should be machined (See chapter 06 - Machining and assemblage of profiles, page 06.20).

Example of calculation of outside/inside opening single-leaf door with basement and automatic threshold

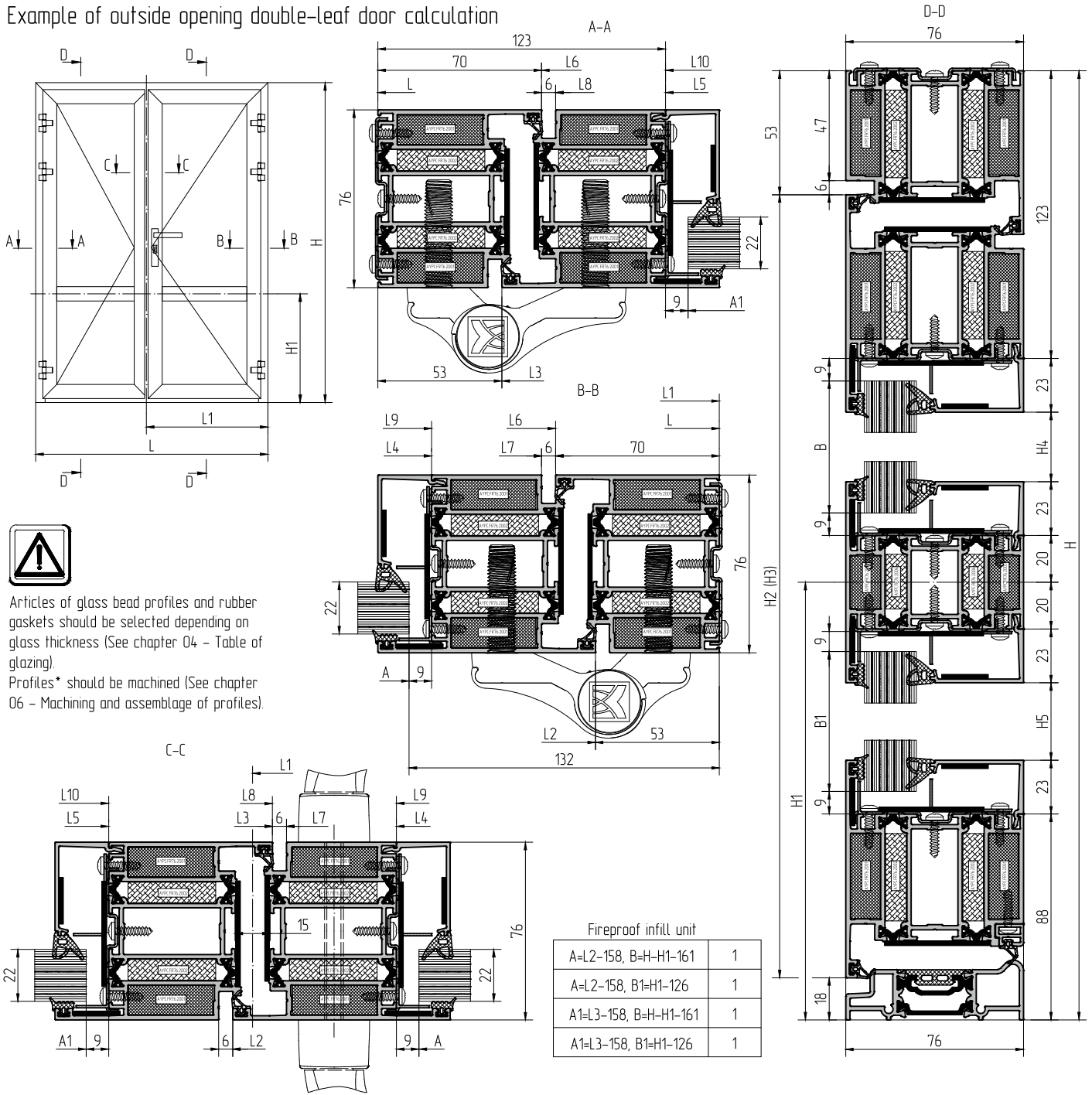


Article	Description	Image	1...
Components			
AYPC.FR76.1001	Steel holder		$FS1=(L+Hx2)/500$
AYPC.FR76.1002	Steel holder		$FS2=(L1+H2x2+L2x2+L3)/300$
AYPC.FR76.1003	Clamping corner		4
AYPC.FR76.1010	Steel holder		$FS10=(L1+H2x2+L2x2+L3)/300$
AYPC.W72.1009	Fireproof insert kit		3
* AYPC.W72.1010	Upper fireproof insert kit		1
* LTU10x2	Thermal sealing tape		$L1x2+H2x2+L3x2$
* LTU50x2	Thermal sealing tape		$L+Hx2+H2+(A+B)x2+(A+B1)x2$
LTU10x2	Thermal sealing tape		$L3x2$
LTU20x2	Thermal sealing tape		$(A+B)x2+(A+B1)x2+L4x4+(H3+H4)x2+L3x2$
LTU50x2	Thermal sealing tape		$L+Hx2+L1+H2x2+(A+B)x2+(A+B1)x2$
AYPC.FR76.2001	Fireproof insert		$Lx2+Hx4+L1x2+H2x4$
AYPC.FR76.2002	Fireproof insert		$Lx2+Hx4+L1x2+H2x4$
AYPC.FR76.2003	Fireproof insert		$L2x2$
AYPC.FR76.2004	Fireproof insert		$L2x2$
AYPC.FR76.2006	Fireproof insert		$L3x2$
AYPC.FR76.2007	Fireproof insert		$L3x2$
FRK29-01	Rubber gasket		$(A+B)x2+(A+B1)x2$
FRK67	Rubber gasket		$(A+B)x2+(A+B1)x2$
FRK148	Rubber gasket		$L+Hx2+L1+H2x2$
AYPC.FR76.0902	Wooden support		4
AYPC.FR76.0901	Bearing support		8
100x26x1	Leveling support		8
100x26x3	Leveling support		8
AYPC.FR76.0905	Threshold plug		1
AYPC.FR76.0906	Door adjoining profile collar		2
0715	Clamping corner		6
AYPC.FR76.0955	Clamping corner		8
AYPC.FR76.0951	Transom fixing element		4
AYPC.FR76.0951-02	Transom fixing element		4
3,9x16 DIN7981	Self-tapping screw		$FS1x3+FS2x5+40$
4,2x25 DIN7982	Self-tapping screw		4
3,9x22 DIN7982	Self-tapping screw		1



* Calculation of LTU10x2 and LTU50x2 is given for perimetral door leaf locking.
LTU50x2 is used for all types of closing on the hinges side of door leaf.
* AYPC.W72.1010 is not used in case of perimetral door leaf locking.

Example of outside opening double-leaf door calculation



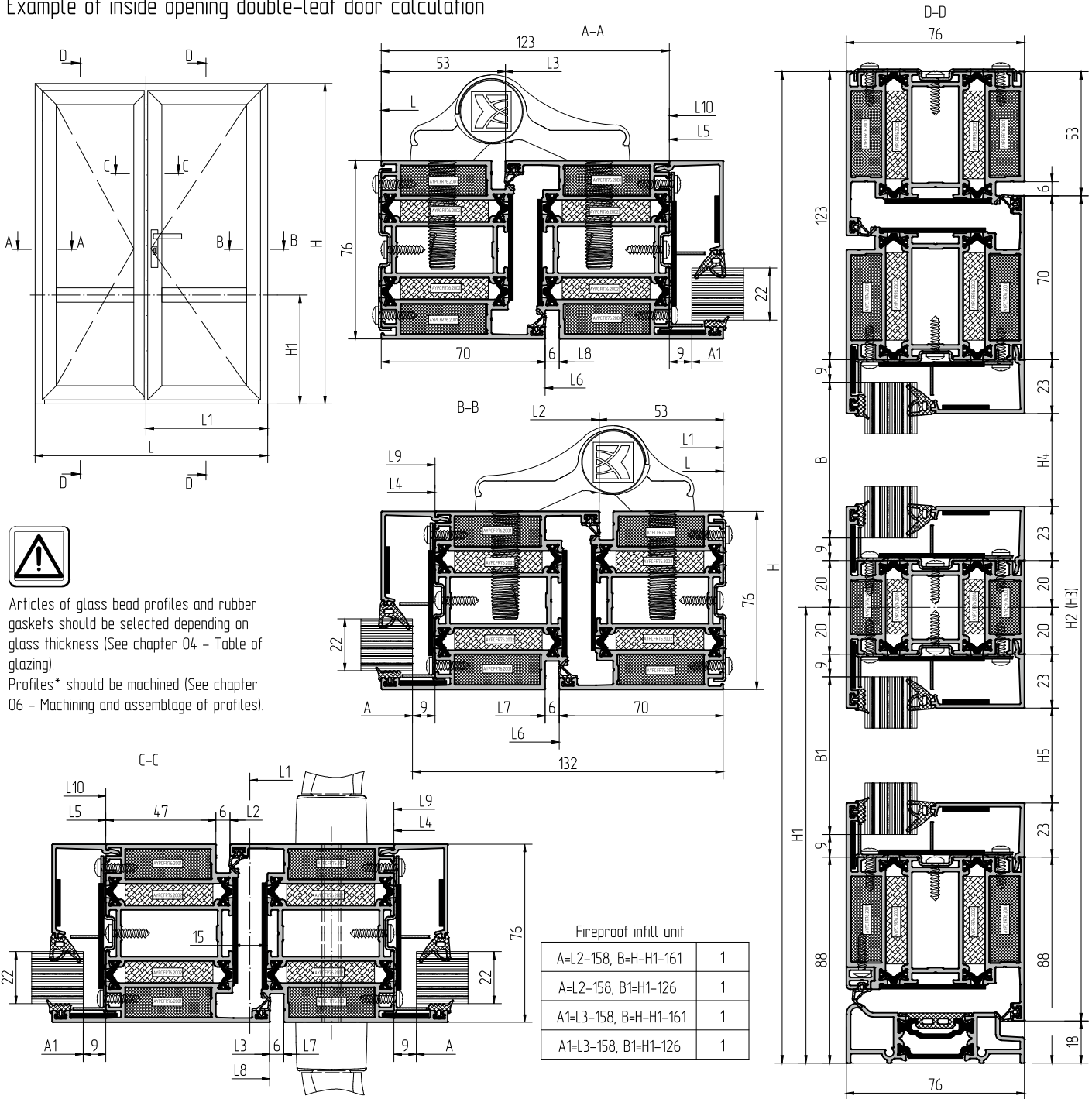
Fireproof infill unit

A=L2-158, B=H-H1-161	1
A=L2-158, B1=H1-126	1
A1=L3-158, B=H-H1-161	1
A1=L3-158, B1=H1-126	1

Article	Description	Image	1...
Profile			
AYPC.FR76.0101	Frame profile		L 1
			H 1
			H 1
AYPC.FR76.0201	Door leaf profile		L2=L1-44,5 2
			* L3=L1-44,5 2
			H2=H-71 3
AYPC.FR76.0202	Door leaf profile		* H3=H-71 1

AYPC.FR76.0301			L4=L2-141 1
			L5=L3-141 1
AYPC.FR76.0801			L6=L-140 1
AYPC.FR76.0614			L7=L2-46 1
			L8=L3-23 1
AYPC.FR76.0608			* L9=L4 4
			* L10=L5 4
			H4=H-H1-189 4
			H5=H1-154 4

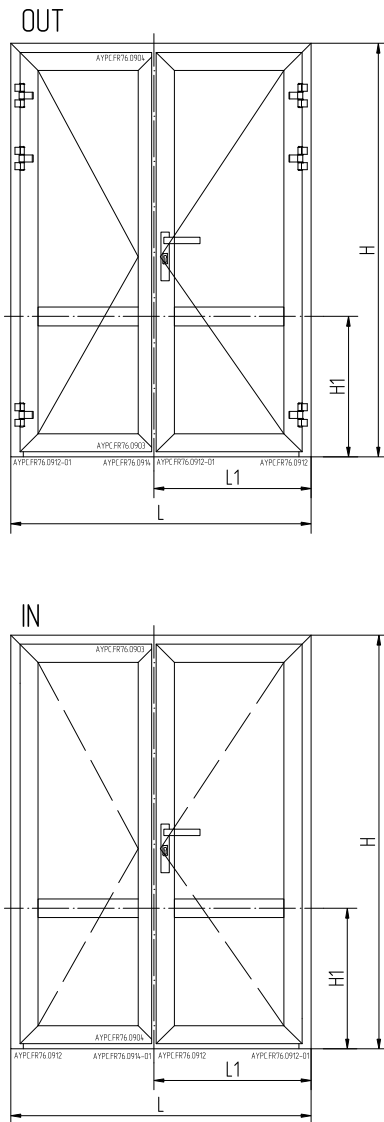
Example of inside opening double-leaf door calculation



Article	Description	Image	1...
Profile			
AYPC.FR76.0101	Frame profile		L
			H
			H
AYPC.FR76.0202	Door leaf profile		L2=L1-44,5
			* L3=L1-44,5
			H2=H-71
AYPC.FR76.0201	Door leaf profile		* H3=H-71

AYPC.FR76.0301	Transom bar profile		L4=L2-141	1
			L5=L3-141	1
AYPC.FR76.0801	Threshold profile		L6=L-140	1
AYPC.FR76.0614	Door adjoining profile		L7=L2-46	1
			L8=L3-23	1
AYPC.FR76.0608	Glass bead profile		* L9=L4	4
			* L10=L5	4
			H4=H-H1-189	4
			H5=H1-154	4

Example of outside/inside opening double-leaf door calculation

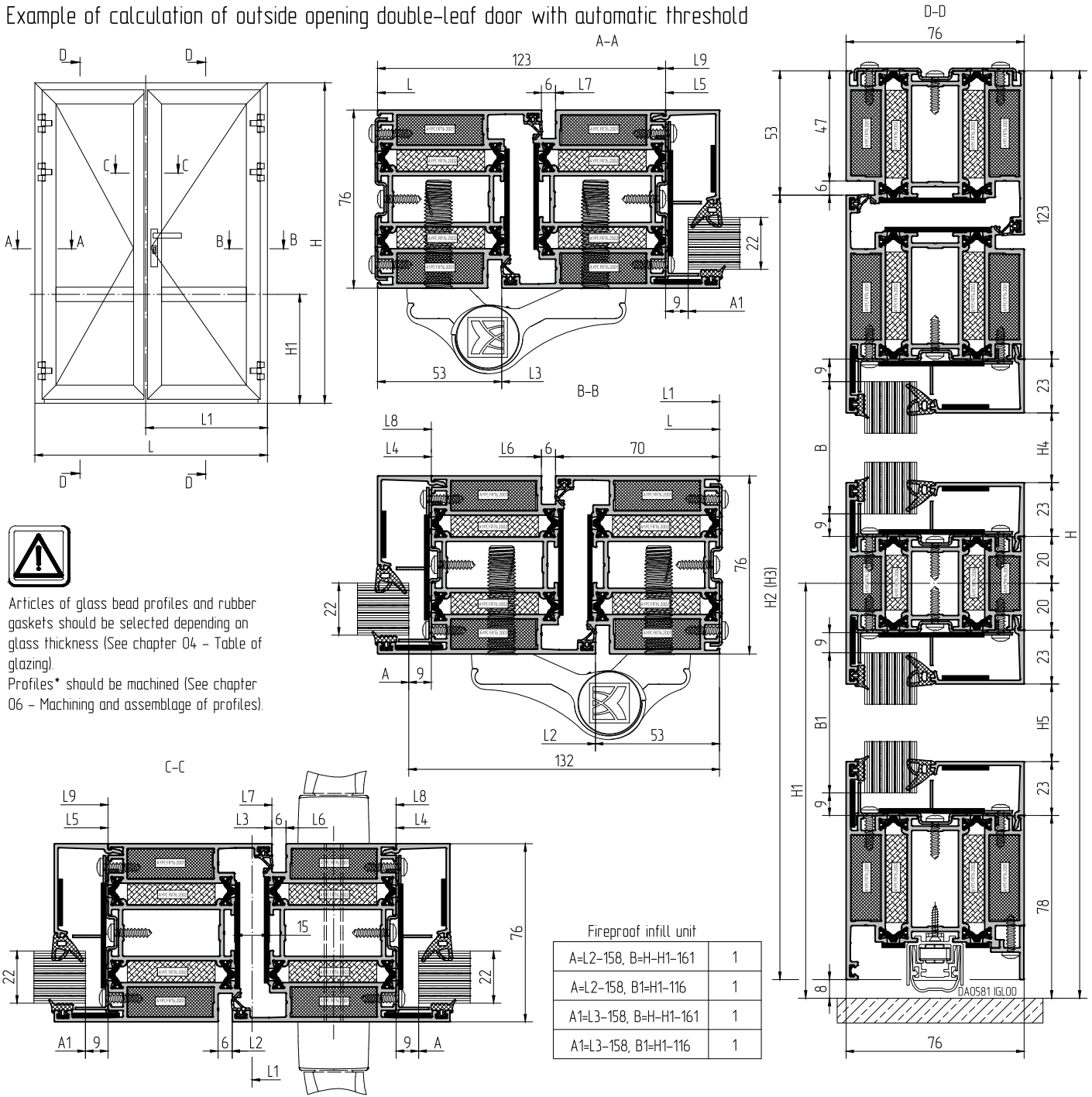


Article	Description	Image		1...
Components				
AYPC.FR76.1001	Steel holder		$FS1=(L+Hx2)/500$	
AYPC.FR76.1002	Steel holder		$FS2=(L2x2+L3x2+L4x2+L5x2+H2x4)/300$	
AYPC.FR76.1003	Clamping corner			4
AYPC.FR76.1010	Steel holder		$FS10=FS2$	
AYPC.W72.1009	Fireproof insert kit			6
* AYPC.W72.1010	Upper fireproof insert kit			1
* LTU10x2	Thermal sealing tape		$L2x4+H2x2$	
* LTU50x2	Thermal sealing tape		$L+Hx2+L3x2+H2x2+H3+(A+A1)x4+(B+B1)x4$	
LTU20x2	Thermal sealing tape		$(A+A1)x4+(B+B1)x4+(L9-L10)x4+(H4+H5)x4$	
LTU50x2	Thermal sealing tape		$L+Hx2+L2x2+L3x2+H2x3+H3+(A+A1)x4+(B+B1)x4$	
AYPC.FR76.2001	Fireproof insert		$Lx2+Hx4+L2x4+H2x8+L3x4$	
AYPC.FR76.2002	Fireproof insert		$Lx2+Hx4+L2x4+H2x8+L3x4$	
AYPC.FR76.2003	Fireproof insert		$L4x2+L5x2$	
AYPC.FR76.2004	Fireproof insert		$L4x2+L5x2$	
FRK29-01	Rubber gasket		$(A+B+A1+B1)x4$	
FRK67	Rubber gasket		$(A+B+A1+B1)x4$	
FRK148	Rubber gasket		$L+Hx2+L2x3+L3x3+H2x4+L7+L8$	
FRK155	Rubber gasket		$L6$	
AYPC.FR76.0902	Wooden support			8
AYPC.FR76.0901	Bearing support			16
100x26x1	Leveling support			16
100x26x3	Leveling support			16
AYPC.FR76.0903	End ledge plug			ДН-1; ДС-2
AYPC.FR76.0904	End ledge plug			ДН-2; ДС-1
AYPC.FR76.0908	Threshold plug			1
AYPC.FR76.0908-01	Threshold plug			1
AYPC.FR76.0909	Threshold plug			1
AYPC.FR76.0909-01	Threshold plug			1
AYPC.FR76.0912	Door adjoining profile collar			ДН-1; ДС-2
AYPC.FR76.0912-01	Door adjoining profile collar			ДН-2; ДС-1
AYPC.FR76.0914	Door adjoining profile collar			ДН-1
AYPC.FR76.0914-01	Door adjoining profile collar			ДС-1
0715	Clamping corner			16
AYPC.FR76.0955	Clamping corner			20
AYPC.FR76.0951	Transom fixing element			8
3,9x16 DIN7981	Self-tapping screw		$FS1x3+FS2x5+80$	
3,9x16 DIN7981	Self-tapping screw		$(L7-L8)/250$	
4,2x19 DIN7981	Self-tapping screw			4
4,2x25 DIN7982	Self-tapping screw			12



* Calculation of LTU10x2 and LTU50x2 is given for perimetral door leaf locking.
 LTU50x2 is used for all types of closing on the hinges side of door leaf.
 * AYPC.W72.1010 is not used in case of perimetral door leaf locking.

Example of calculation of outside opening double-leaf door with automatic threshold



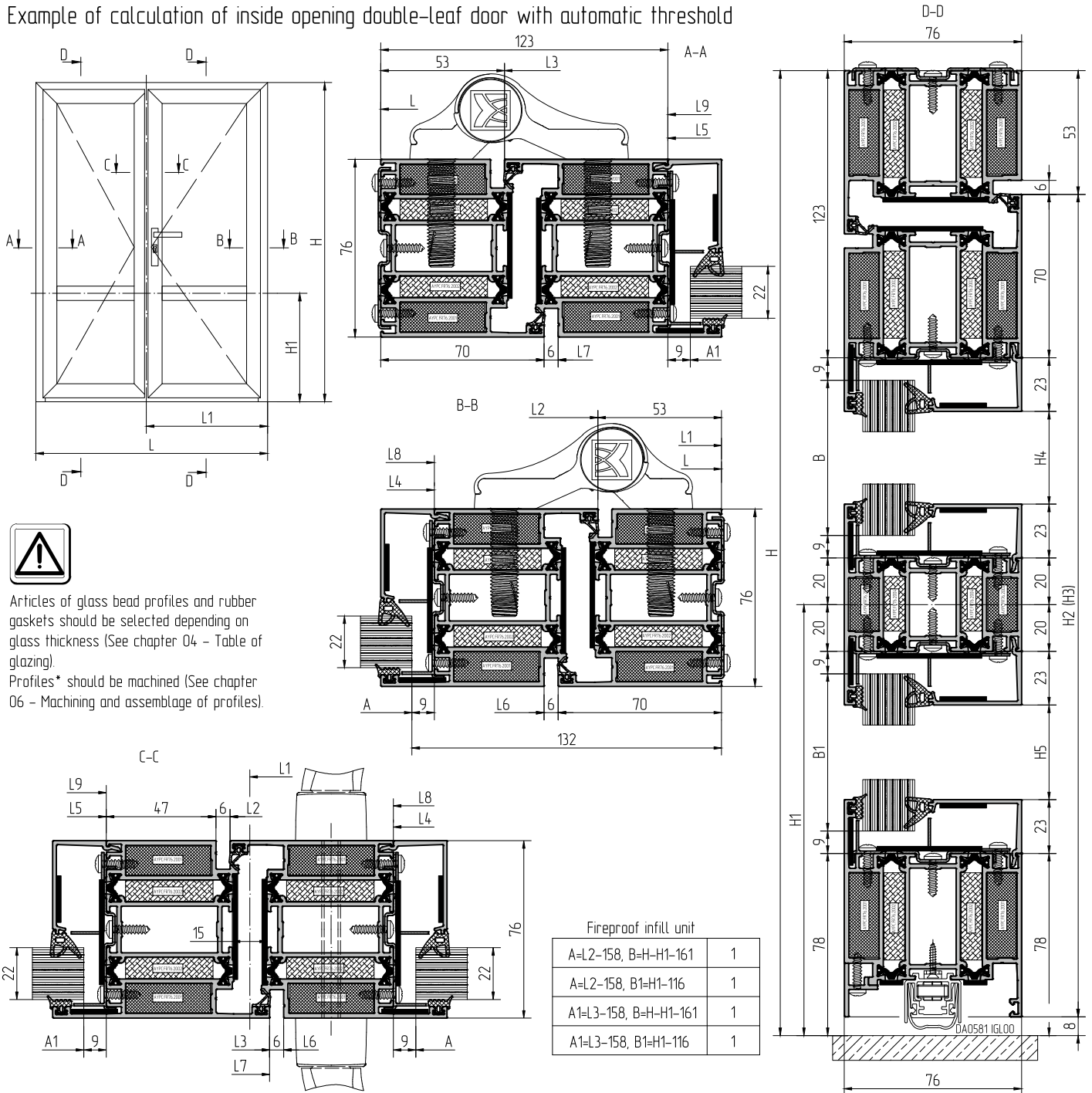
Article	Description	Image	1...
Profile			
AYPC.FR76.0101	Frame profile		L 1
			H 1
			H 1
AYPC.FR76.0201	Door leaf profile		L2=L1-44,5 2
			* L3=L1-44,5 2
			H2=H-61 3
AYPC.FR76.0202	Door leaf profile		* H3=H-61 1

AYPC.FR76.0301			L4=L2-141	1
			L5=L3-141	1
AYPC.FR76.0613			L6=L2-50	1
			L7=L3-27	1
AYPC.FR76.0608			* L8=L4	4
			* L9=L5	4
			H4=H-H1-189	4
			H5=H1-144	4

L(DA0581 IGL00) = L2 - 32	1
L(DA0581 IGL00) = L3 - 32	1



Example of calculation of inside opening double-leaf door with automatic threshold



Articles of glass bead profiles and rubber gaskets should be selected depending on glass thickness (See chapter 04 - Table of glazing). Profiles* should be machined (See chapter 06 - Machining and assemblage of profiles).

Fireproof infill unit

A=L2-158, B=H-H1-161	1
A=L2-158, B1=H1-116	1
A1=L3-158, B=H-H1-161	1
A1=L3-158, B1=H1-116	1

Article	Description	Image	1....
Profile			
AYPC.FR76.0101	Frame profile		L 1
			H 1
			H 1
AYPC.FR76.0202	Door leaf profile		L2=L1-44,5 2
			* L3=L1-44,5 2
			H2=H-61 3
AYPC.FR76.0201	Door leaf profile		* H3=H-61 1

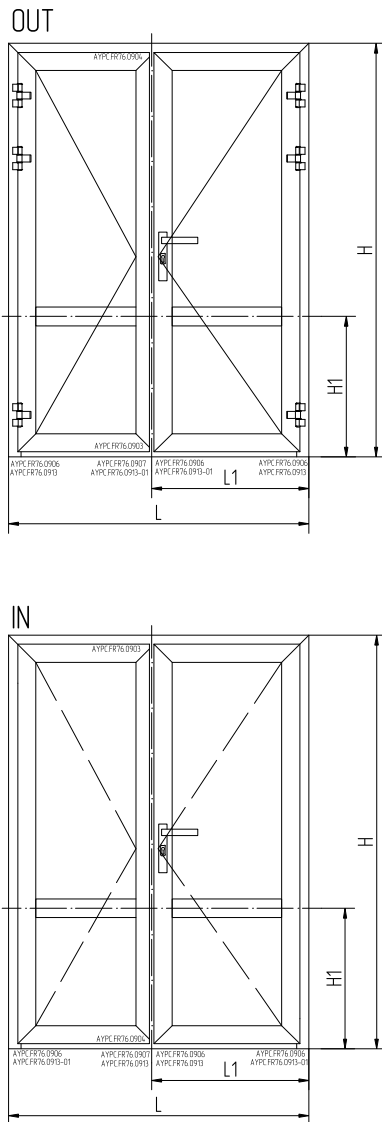
AYPC.FR76.0301			L4=L2-141 1
			L5=L3-141 1
AYPC.FR76.0613			L6=L2-50 1
			L7=L3-27 1
AYPC.FR76.0608			* L8=L4 4
			* L9=L5 4
			H4=H-H1-189 4
			H5=H1-144 4

DA0581 IGL00 Threshold

L(DA0581 IGL00) = L2 - 32	1
L(DA0581 IGL00) = L3 - 32	1



Example of calculation of outside/inside opening double-leaf door with automatic threshold

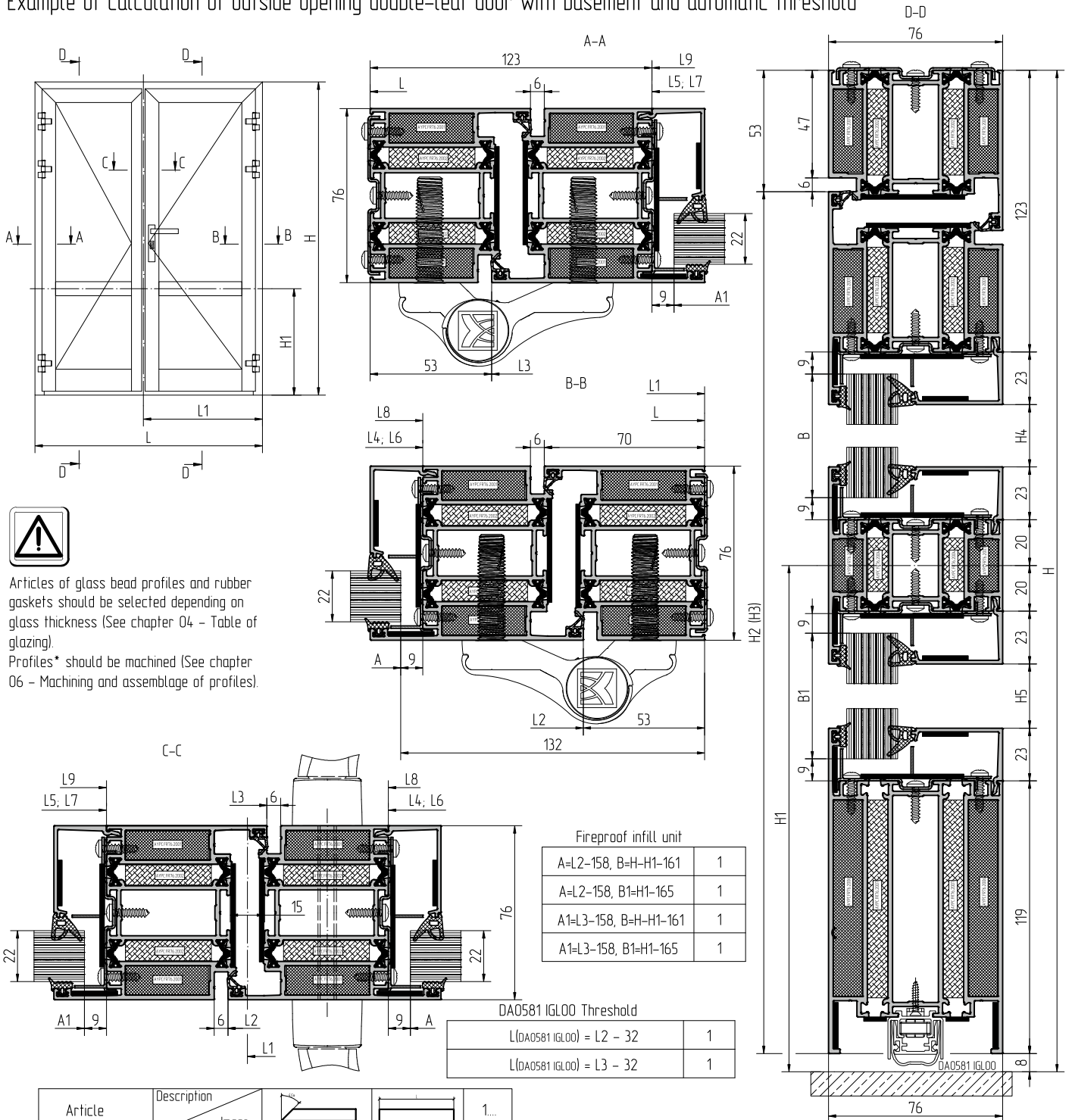


Article	Description	Image		1...
Components				
AYPC.FR76.1001	Steel holder		$FS1=(L+Hx2)/500$	
AYPC.FR76.1002	Steel holder		$FS2=(L2x2+L3x2+L4x2+L5x2+H2x4)/300$	
AYPC.FR76.1003	Clamping corner			4
AYPC.FR76.1010	Steel holder		$FS10=FS2$	
AYPC.W72.1009	Fireproof insert kit			6
* AYPC.W72.1010	Upper fireproof insert kit			1
* LTU10x2	Thermal sealing tape		$L2x4+L3x2+H2x2$	
* LTU50x2	Thermal sealing tape		$L+Hx2+L3+H2x2+H3+(A+A1)x4+(B+B1)x4$	
LTU10x2	Thermal sealing tape		$L2x2+L3x2$	
LTU20x2	Thermal sealing tape		$(A+A1)x4+(B+B1)x4+(L8+L9)x4+(H4+H5)x4$	
LTU50x2	Thermal sealing tape		$L+Hx2+L2+L3+H2x3+H3+(A+A1)x4+(B+B1)x4$	
AYPC.FR76.2001	Fireproof insert		$Lx2+Hx4+L2x4+H2x8+L3x4$	
AYPC.FR76.2002	Fireproof insert		$Lx2+Hx4+L2x4+H2x8+L3x4$	
AYPC.FR76.2003	Fireproof insert		$L4x2+L5x2$	
AYPC.FR76.2004	Fireproof insert		$L4x2+L5x2$	
FRK29-01	Rubber gasket		$(A+B+A1+B1)x4$	
FRK67	Rubber gasket		$(A+B+A1+B1)x4$	
FRK148	Rubber gasket		$L+Hx2+L2+L3+H2x4$	
AYPC.FR76.0902	Wooden support			8
AYPC.FR76.0901	Bearing support			16
100x26x1	Leveling support			16
100x26x3	Leveling support			16
AYPC.FR76.0903	End ledge plug			$\Delta H-1; \Delta C-2$
AYPC.FR76.0904	End ledge plug			$\Delta H-2; \Delta C-1$
AYPC.FR76.0905	Threshold plug			2
AYPC.FR76.0906	Threshold collar			3
AYPC.FR76.0907	Threshold collar			1
AYPC.FR76.0913	Door adjoining profile plug			2
AYPC.FR76.0913-01	Door adjoining profile plug			2
0715	Clamping corner			16
AYPC.FR76.0955	Clamping corner			20
AYPC.FR76.0951	Transom fixing element			8
3,9x16 DIN7981	Self-tapping screw		$FS1x3+FS2x5+80$	
3,9x16 DIN7981	Self-tapping screw		$(L6+L7)/250$	
4,2x25 DIN7982	Self-tapping screw			8
3,9x22 DIN7982	Self-tapping screw			2



* Calculation of LTU10x2 and LTU50x2 is given for perimetral door leaf locking.
 LTU50x2 is used for all types of closing on the hinges side of door leaf.
 * AYPC.W72.1010 is not used in case of perimetral door leaf locking.

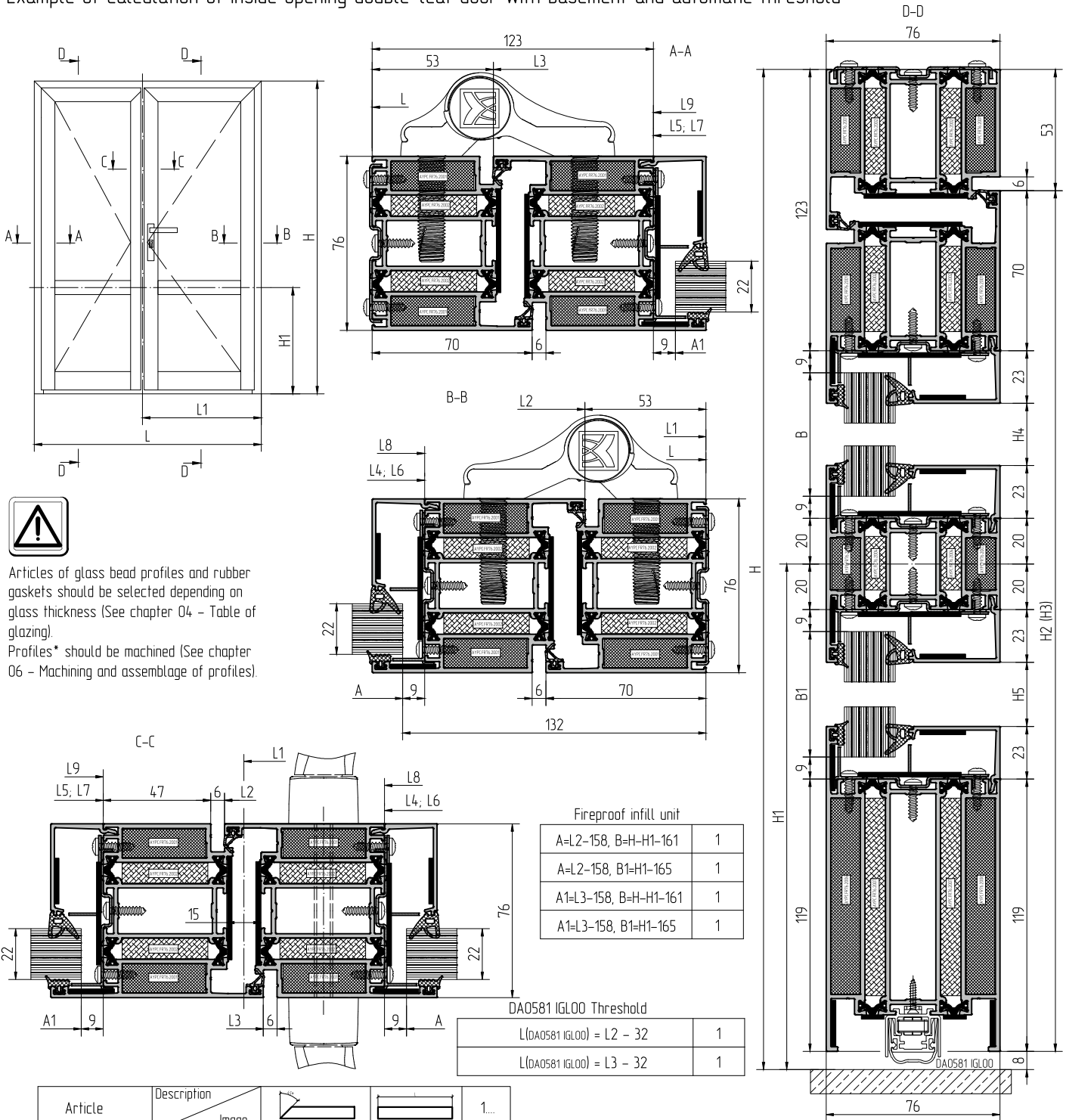
Example of calculation of outside opening double-leaf door with basement and automatic threshold



Article	Description	Image	1...
Profile			
AYPC.FR76.0101	Frame profile		L 1
			H 1
			H 1
AYPC.FR76.0201	Door leaf profile		L2=L1-44,5 1
			* L3=L-L1-44,5 1
			H2=H-61 2
			H2=H-61 1
AYPC.FR76.0202	Door leaf profile		* H3=H-61 1

AYPC.FR76.0105	Frame profile		L4=L2-141 1
			L5=L3-141 1
AYPC.FR76.0301	Transom bar profile		L6=L4 1
			L7=L5 1
AYPC.FR76.0608	Glass bead profile		* L8=L4 4
			* L9=L5 4
			H4=H-H1-189 4
			H5=H1-193 4

Example of calculation of inside opening double-leaf door with basement and automatic threshold

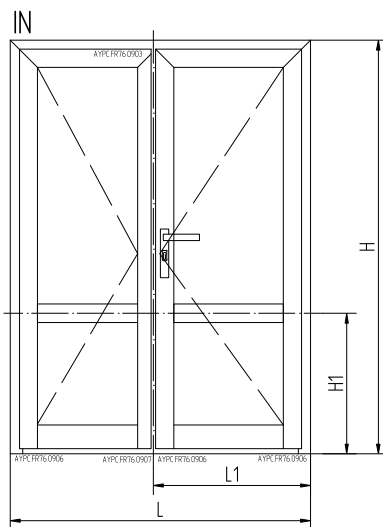
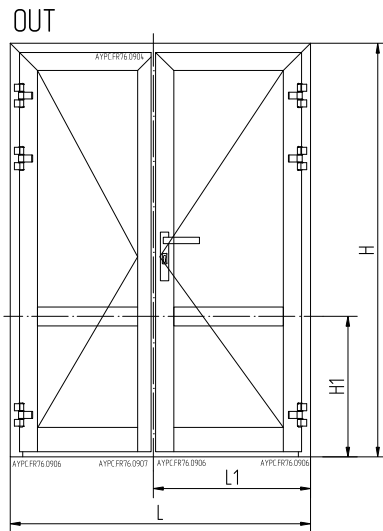


Article	Description	Image	1...
Profile			
AYPC.FR76.0101	Frame profile		L 1
			H 1
			H 1
AYPC.FR76.0202	Door leaf profile		L2=L1-44,5 1
			* L3=L1-44,5 1
			H2=H-61 2
			H2=H-61 1
AYPC.FR76.0201	Door leaf profile		* H3=H-61 1

AYPC.FR76.0105	Frame profile		L4=L2-141 1
			L5=L3-141 1
AYPC.FR76.0301	Transom bar profile		L6=L4 1
			L7=L5 1
AYPC.FR76.0608	Glass bead profile		* L8=L4 4
			* L9=L5 4
			H4=H-H1-189 4
			H5=H1-193 4

fapim DOMATIC

Example of calculation of outside/inside opening double-leaf door with basement and automatic threshold

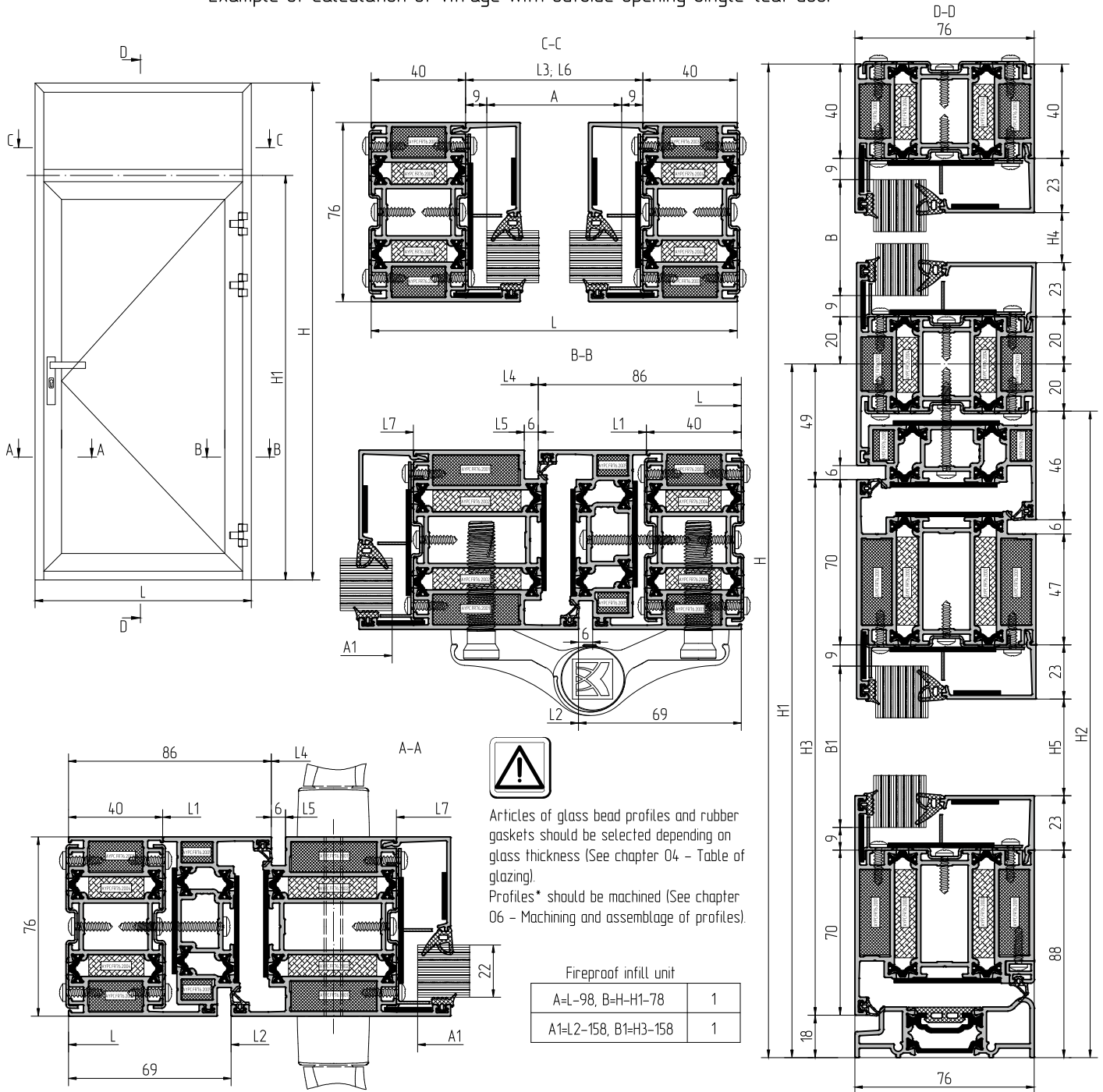


Article	Description	Image		1...
Components				
AYPC.FR76.1001	Steel holder		$FS1=(L+Hx2)/500$	
AYPC.FR76.1002	Steel holder		$FS2=(L2+L3+L4+L5+L6x2+L7x2+H2x4)/300$	
AYPC.FR76.1003	Clamping corner			8
AYPC.FR76.1010	Steel holder		$FS10=FS2$	
AYPC.W72.1009	Fireproof insert kit			6
* AYPC.W72.1010	Upper fireproof insert kit			1
* LTU10x2	Thermal sealing tape		$L2x2+L4x2+L5x2+H2x2$	
* LTU50x2	Thermal sealing tape		$L+Hx2+L3+H2x2+H3+(A+A1)x4+(B+B1)x4$	
LTU10x2	Thermal sealing tape		$L4x2+L5x2$	
LTU20x2	Thermal sealing tape		$(A+A1)x4+(B+B1)x4+(L8+L9)x4+(H4+H5)x4+L4x2+L5x2$	
LTU50x2	Thermal sealing tape		$L+Hx2+L2+L3+H2x3+H3+(A+A1)x4+(B+B1)x4$	
AYPC.FR76.2001	Fireproof insert		$Lx2+Hx4+L2x2+H2x8+L3x2$	
AYPC.FR76.2002	Fireproof insert		$Lx2+Hx4+L2x2+H2x8+L3x2$	
AYPC.FR76.2003	Fireproof insert		$L6x2+L7x2$	
AYPC.FR76.2004	Fireproof insert		$L6x2+L7x2$	
AYPC.FR76.2006	Fireproof insert		$L4x2+L5x2$	
AYPC.FR76.2007	Fireproof insert		$L4x2+L5x2$	
FRK29-01	Rubber gasket		$(A+B+A1+B1)x4$	
FRK67	Rubber gasket		$(A+B+A1+B1)x4$	
FRK148	Rubber gasket		$L+Hx2+L2+L3+H2x4$	
AYPC.FR76.0902	Wooden support			8
AYPC.FR76.0901	Bearing support			16
100x26x1	Leveling support			16
100x26x3	Leveling support			16
AYPC.FR76.0903	End ledge plug			ΔC 2
AYPC.FR76.0904	End ledge plug			ΔH 2
AYPC.FR76.0905	Threshold plug			2
AYPC.FR76.0906	Threshold collar			3
AYPC.FR76.0907	Threshold collar			1
0715	Clamping corner			8
AYPC.FR76.0955	Clamping corner			12
AYPC.FR76.0951	Transom fixing element			8
AYPC.FR76.0951-02	Transom fixing element			8
3,9x16 DIN7981	Self-tapping screw		$FS1x3+FS2x5+80$	
4,2x25 DIN7982	Self-tapping screw			8
3,9x22 DIN7982	Self-tapping screw			2



* Calculation of LTU10x2 and LTU50x2 is given for perimeter door leaf locking.
LTU50x2 is used for all types of closing on the hinges side of door leaf.
* AYPC.W72.1010 is not used in case of perimeter door leaf locking.

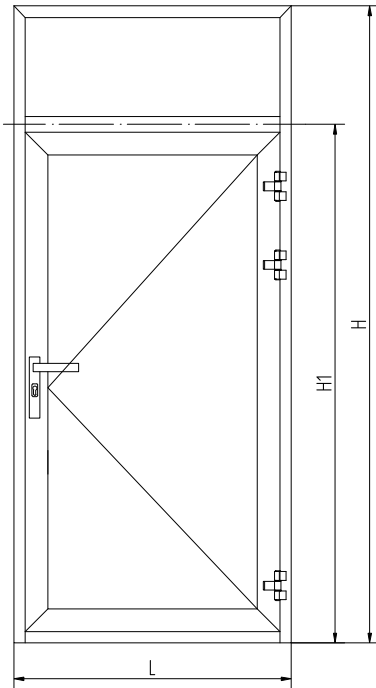
Example of calculation of vitrage with outside opening single-leaf door



Article	Description	Image	1...
Profile			
AYPC.FR76.0103	Frame profile		L 1 H 1 H 1
	Adaptor profile		L1=L-80 1
			H2=H1-20 1 H2=H1-20 1
AYPC.FR76.0201	Door leaf profile		L2=L-138 2 H3=H1-67 2

AYPC.FR76.0301	Transom bar profile		L3=L-81 1
AYPC.FR76.0801	Threshold profile		L4=L-172 1
AYPC.FR76.0614	Door adjoining profile		L5=L-184 1
AYPC.FR76.0608	Glass bead profile		* L6=L3 2
			* L7=L2-140 2
			H4=H-H1-106 2
			H5=H3-186 2

Example of calculation of vitrage with outside opening single-leaf door



Article	Description	Image		1...
Components				
AYPC.FR76.1001	Steel holder		$FS1=(L+Hx2+L1x2+H2x2)/500$	
AYPC.FR76.1002	Steel holder		$FS2=(L2x2+H3x2+L+L3+Bx2)/300$	
AYPC.FR76.1003	Clamping corner			2
AYPC.FR76.1010	Steel holder		$FS10=FS2$	
AYPC.W72.1009	Fireproof insert kit			3
* AYPC.W72.1010	Upper fireproof insert kit			1
* LTU10x2	Thermal sealing tape		$L2x2+H3$	
* LTU50x2	Thermal sealing tape		$L1x2+H2x4+H3+(A+A1)x2+(B+B1)x2$	
LTU20x2	Thermal sealing tape		$(A+A1)x2+(B+B1)x2+(L6+L7)x2+(H4+H5)x2$	
LTU50x2	Thermal sealing tape		$L1x2+H2x4+L2x2+H3x2+(A+A1)x2+(B+B1)x2$	
AYPC.FR76.2001	Fireproof insert		$L2x4+H3x4$	
AYPC.FR76.2002	Fireproof insert		$L2x4+H3x4$	
AYPC.FR76.2003	Fireproof insert		$Lx2+Hx4+L3x2$	
AYPC.FR76.2004	Fireproof insert		$Lx2+Hx4+L3x2$	
AYPC.FR76.2005	Fireproof insert		$L1x2+H2x4$	
FRK29-01	Rubber gasket		$(A+B)x2+(A1+B1)x2$	
FRK67	Rubber gasket		$(A+B)x2+(A1+B1)x2$	
FRK148	Rubber gasket		$L1+H2x2+L2x3+H3x2$	
FRK155	Rubber gasket		$L4$	
AYPC.FR76.0902	Wooden support			8
AYPC.FR76.0901	Bearing support			8
100x26x1	Leveling support			8
100x26x3	Leveling support			8
AYPC.FR76.0908	Threshold plug			1
AYPC.FR76.0908-01	Threshold plug			1
AYPC.FR76.0909	Threshold plug			1
AYPC.FR76.0909-01	Threshold plug			1
AYPC.FR76.0912	Door adjoining profile collar			1
AYPC.FR76.0912-01	Door adjoining profile collar			1
0715	Clamping corner			12
AYPC.FR76.0952	Clamping corner			4
AYPC.FR76.0953	Clamping corner			4
AYPC.FR76.0955	Clamping corner			8
AYPC.FR76.0951	Transom fixing element			4
3,9x16 DIN7981	Self-tapping screw		$FS1x3+FS2x5+40$	
3,9x16 DIN7981	Self-tapping screw		$L5/250$	
4,8x38 DIN7981	Self-tapping screw		$(L1+Hx2)/300$	
4,2x19 DIN7981	Self-tapping screw			4
4,2x25 DIN7982	Self-tapping screw			12



* Calculation of LTU10x2 and LTU50x2 is given for perimetral door leaf locking
 LTU50x2 is used for all types of closing on the hinges side of door leaf.
 * AYPC.W72.1010 is not used in case of perimetral door leaf locking



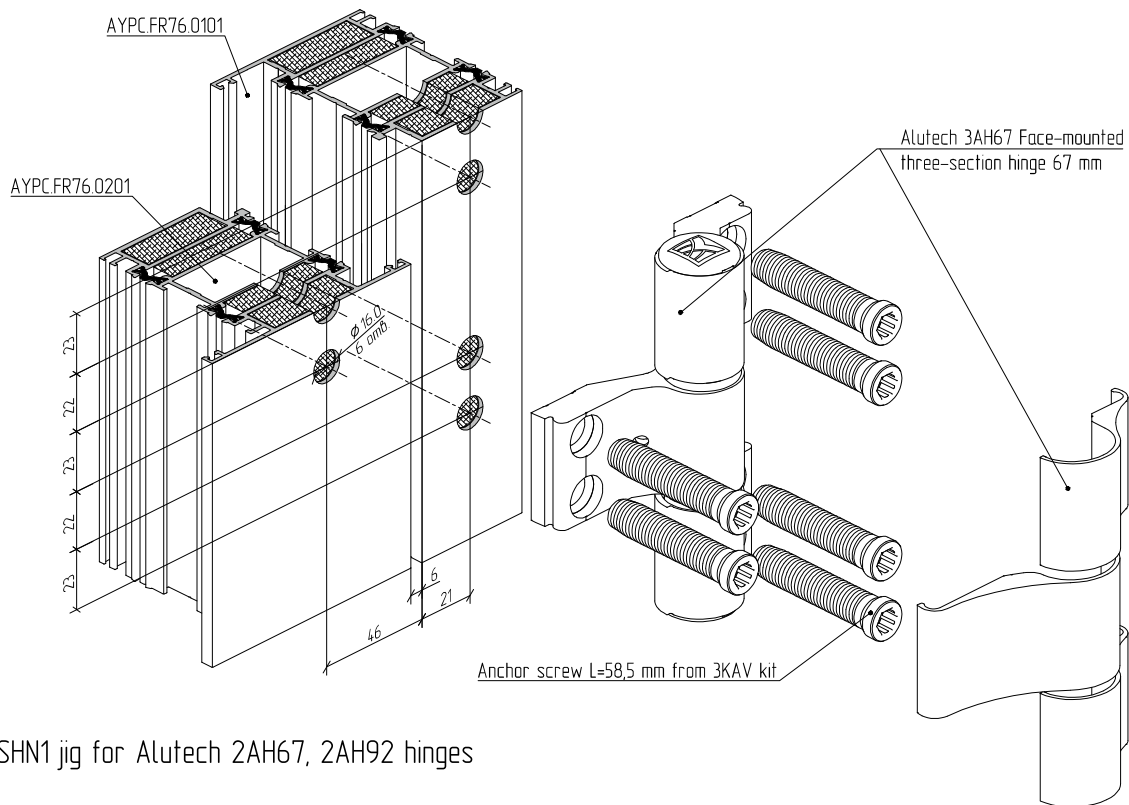
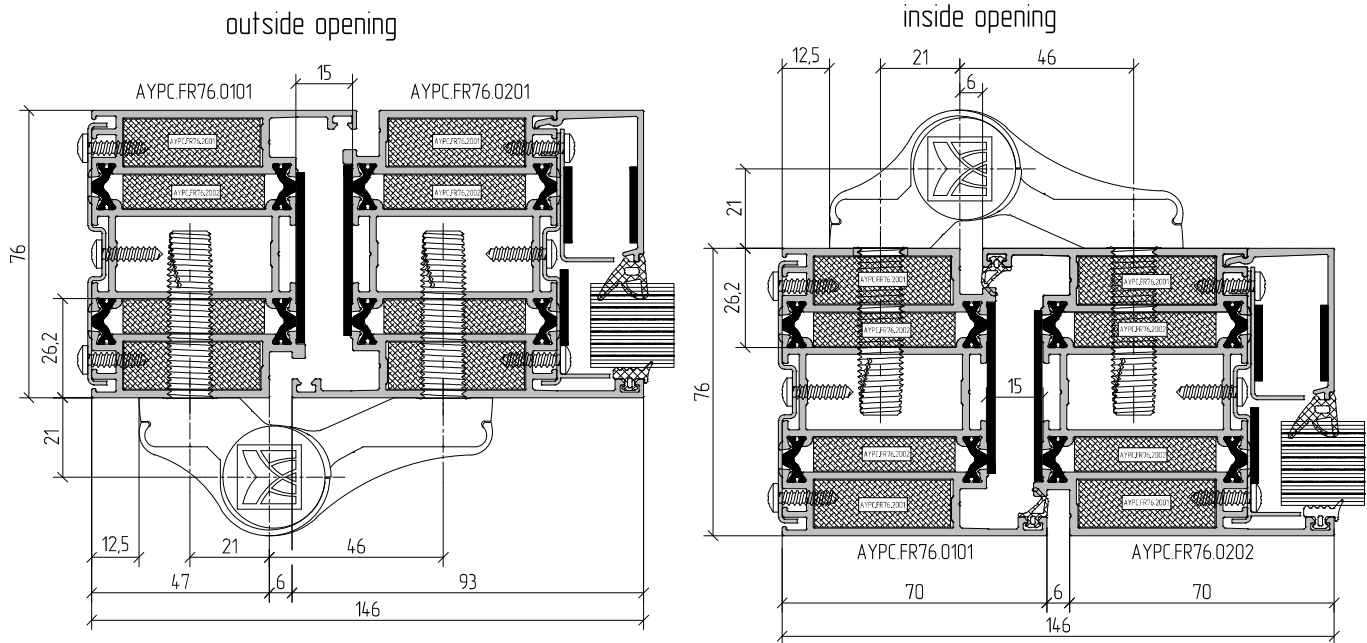
ALT FR76

FIRE RESISTANT
DOORS WITH DOUBLE
THERMAL BREAK

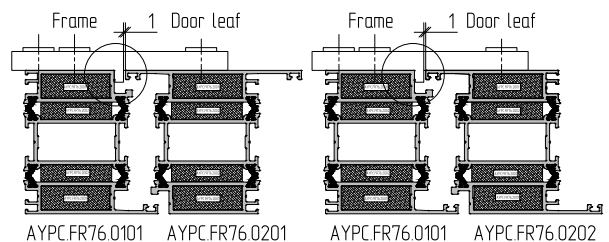
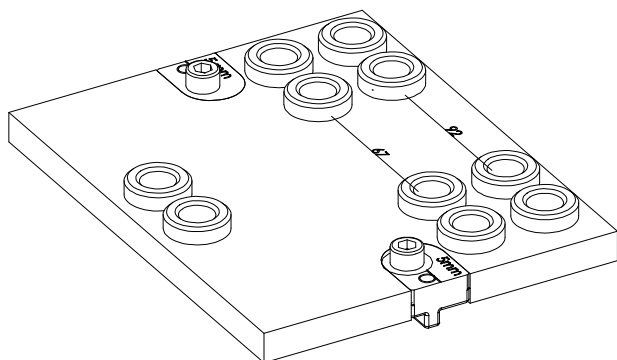
HARDWARE

08

Examples of face mounted hinges installation on door leaf and frame profiles of fire-resistant door system



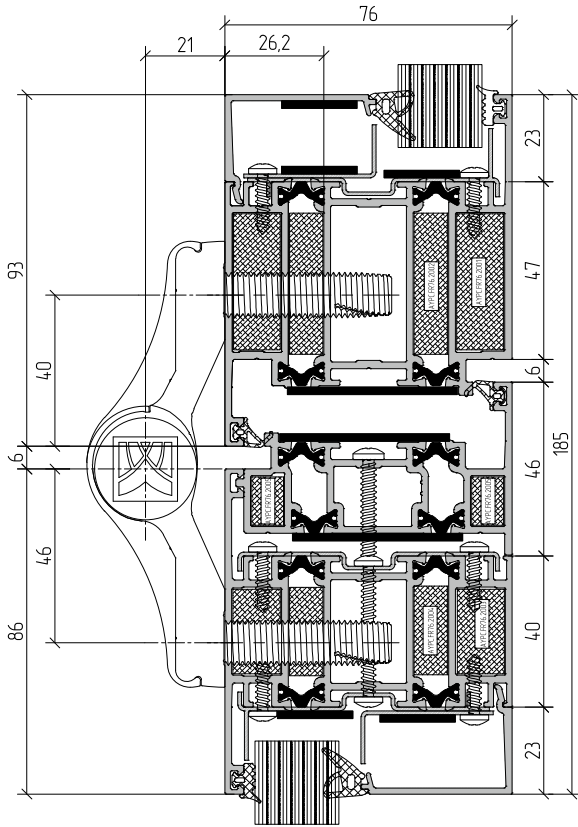
SHN1 jig for Alutech 2AH67, 2AH92 hinges



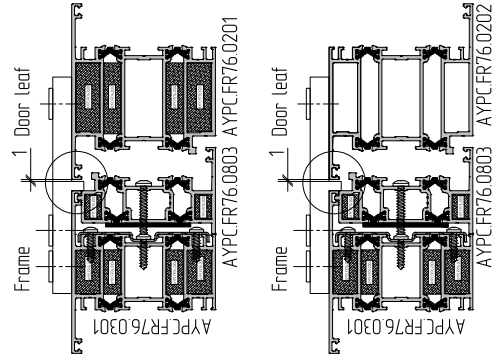
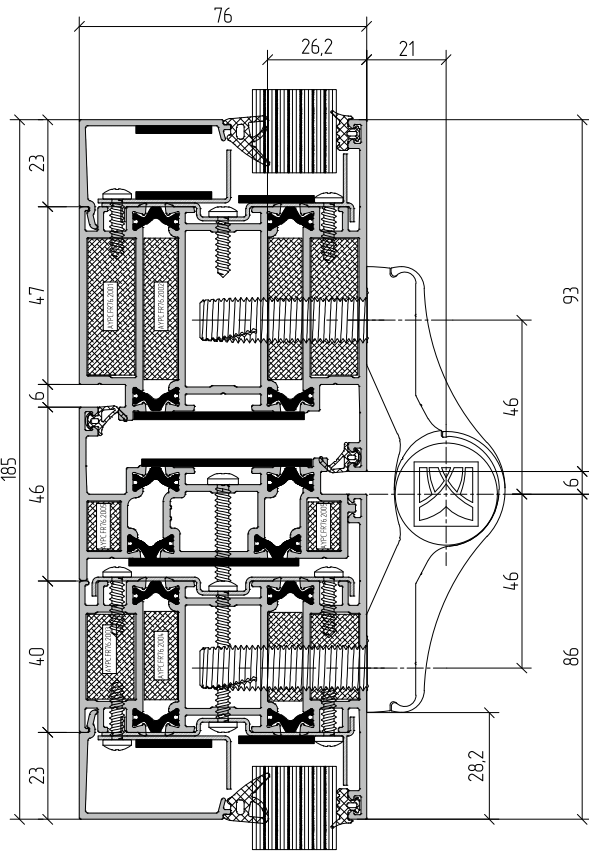
Note! Make jig positioning along the frame.

ALUTECH

Example of face mounted hinges installation on door leaf and frame profiles of fire-resistant door system inside opening



outside opening

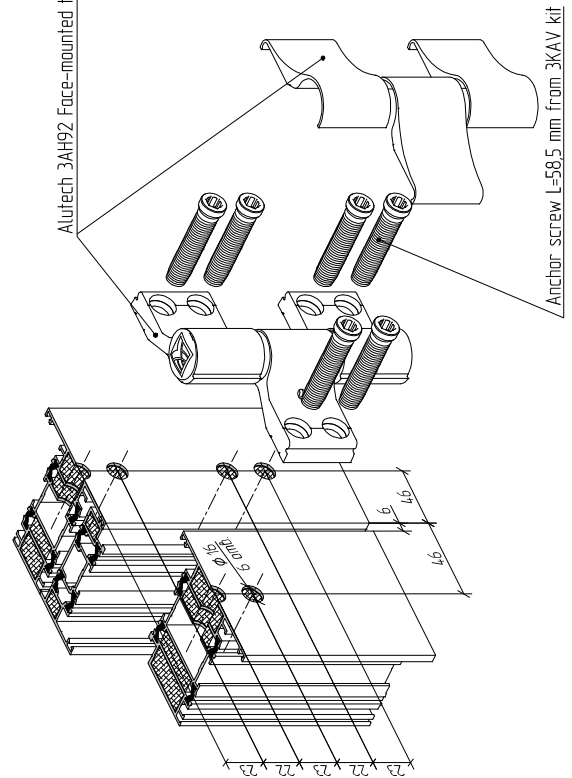


⚠ Note! Make jig positioning along the frame.

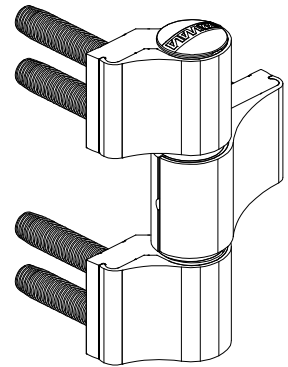
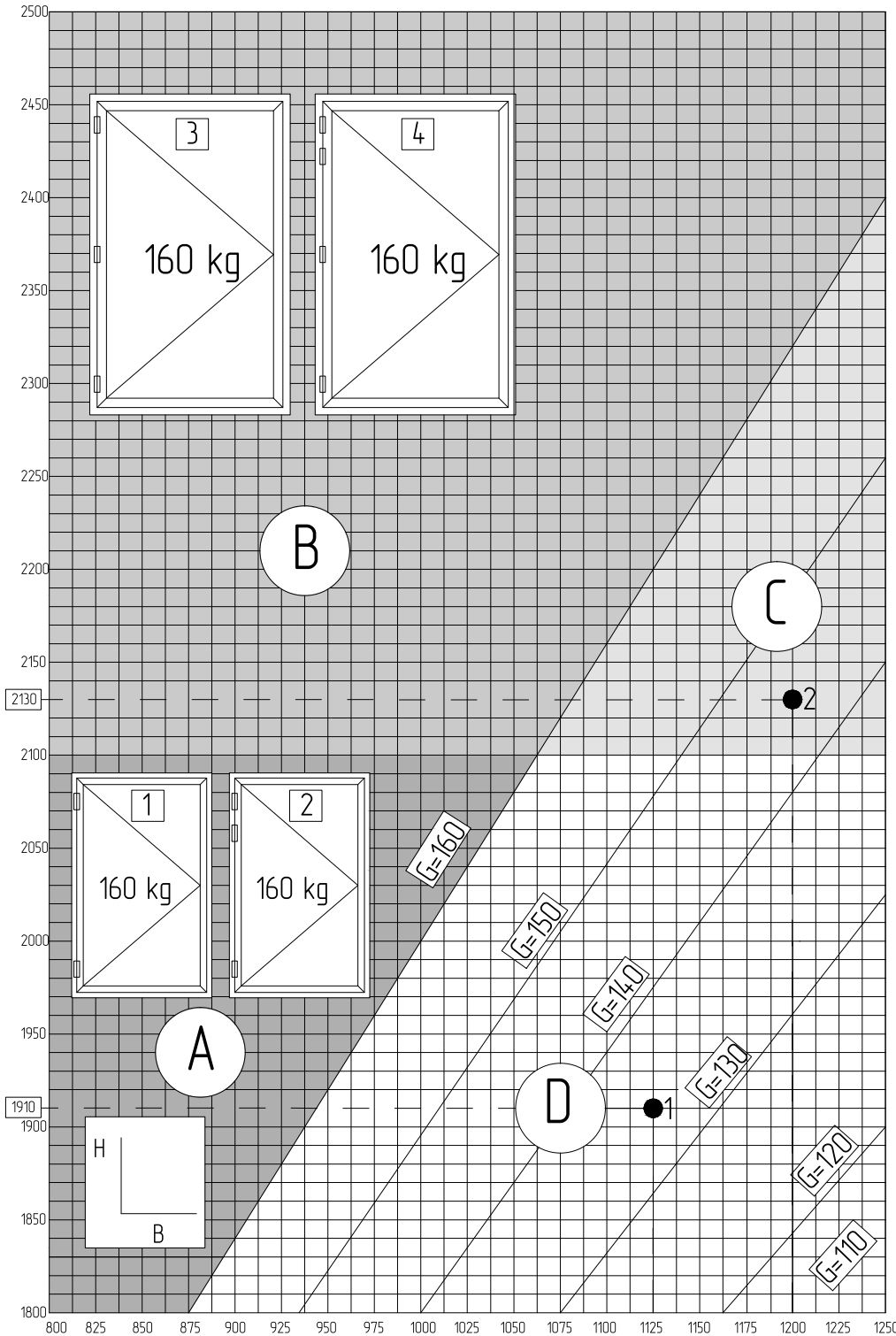


Alutech 3AH92 Face-mounted three-section hinge 92 mm

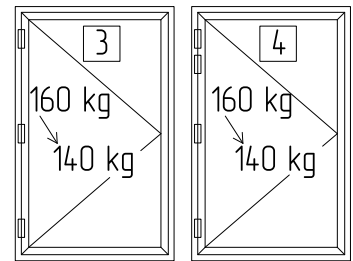
SHN1 jig for Alutech 2AH67, 2AH92 hinges



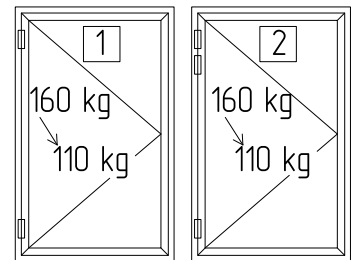
Scheme of hinges installation depending on door leaf weight and dimensions.



Alutech hinges for C zone



For D zone



A and B zone Door leaf max. weight – 160 kg.

D zone Door leaf max. weight – 160 ... 110 kg, depending on dimensions

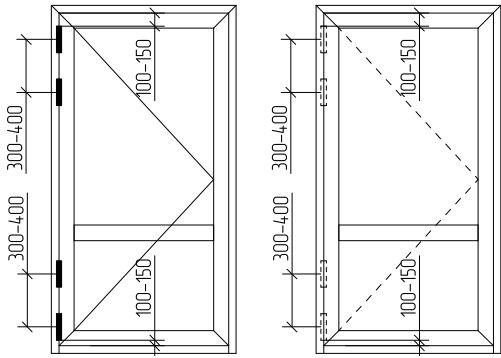
C zone Door leaf max. weight – 160 ... 140 kg, depending on dimensions

1,2,3,4 – Hinges installation options. 2 and 4 options are acceptable in case of intensive doors using (e.g. public buildings) or using of door closers and automatic drives

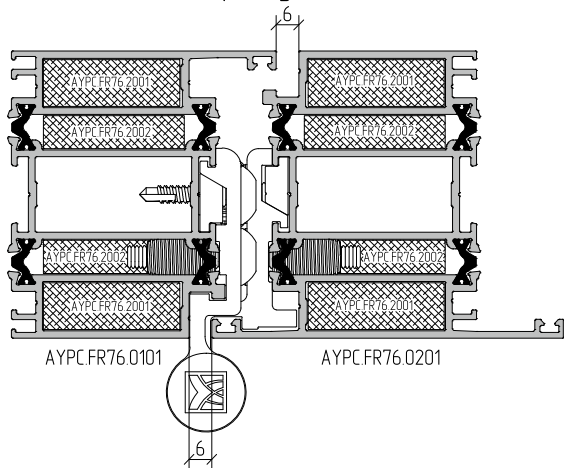
Option 1 H = 1910 mm B = 1125 mm Door leaf weight – 135 kg (interpolation between lines G=140 and G=130)

Option 2 H = 2130 mm B = 1200 mm Door leaf weight – 145 kg (interpolation between lines G=150 and G=140)

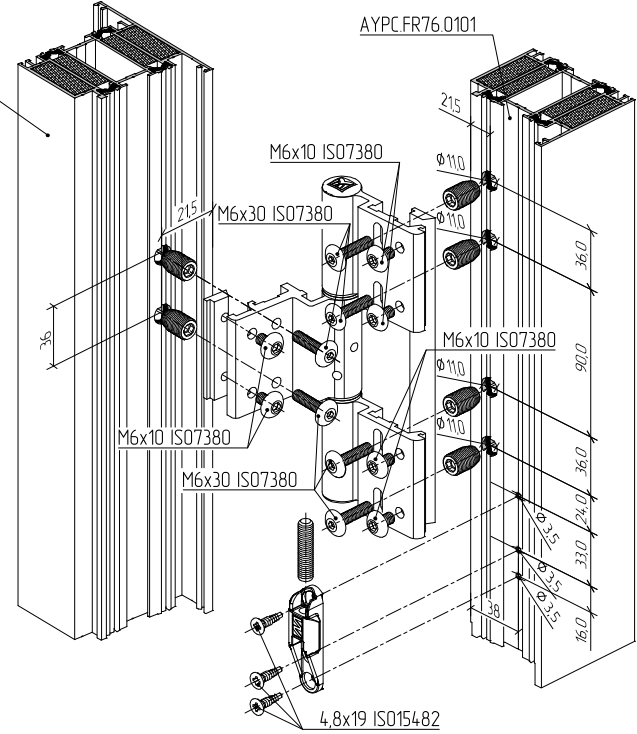
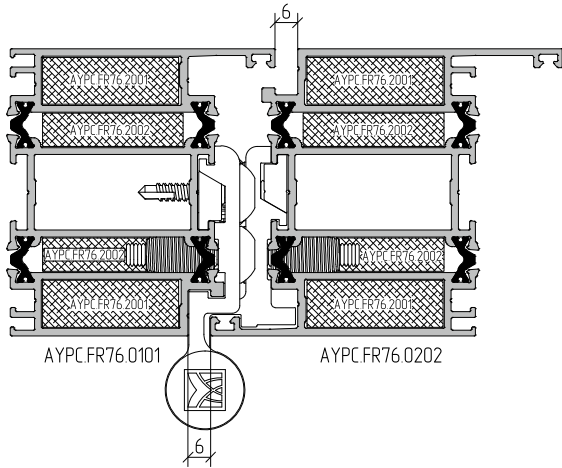
Examples of RFR76 roller hinges installation on door leaf and frame profiles



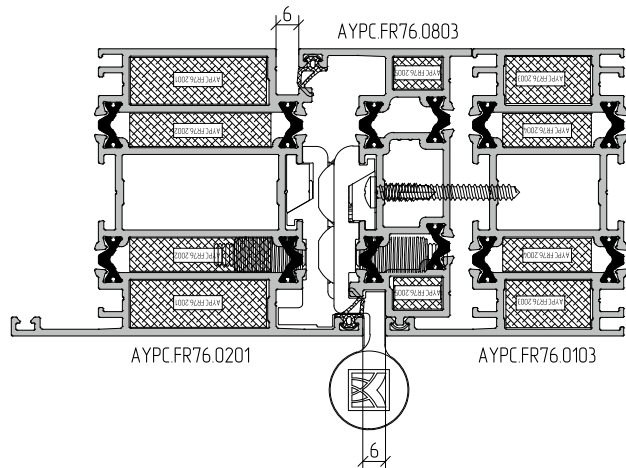
Outside-opening door



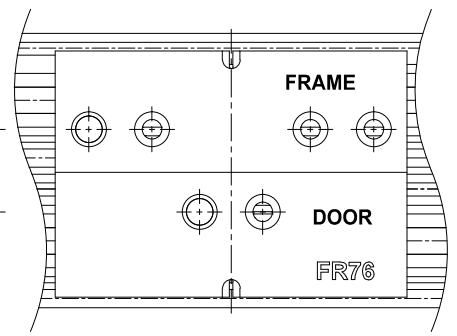
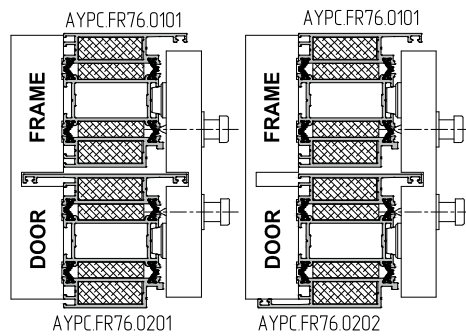
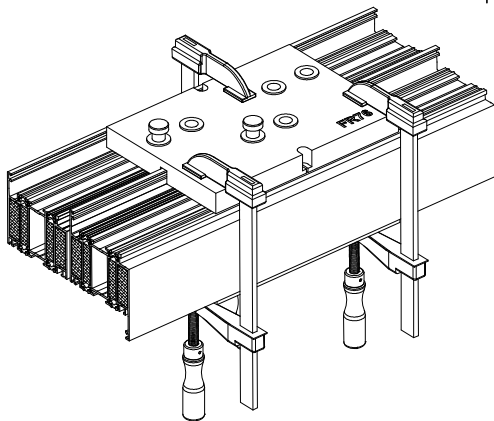
Inside-opening door



Outside opening

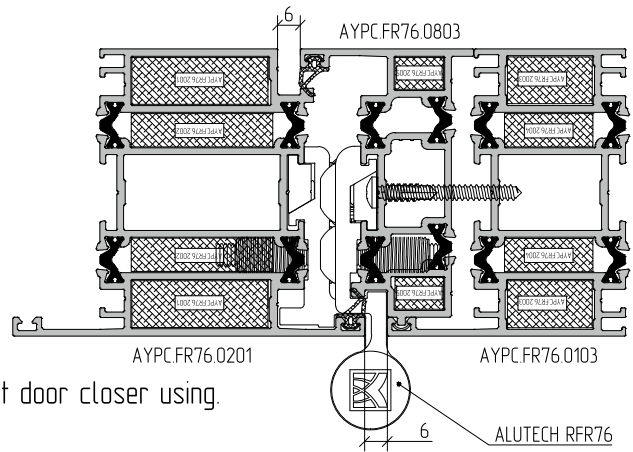
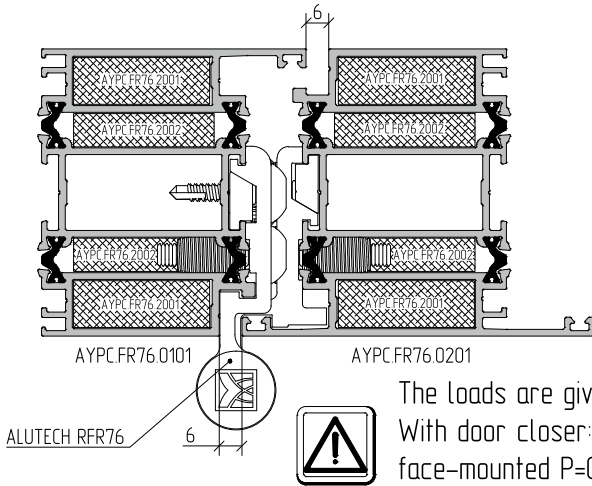


Example of door leaf and frame profiles machining with jig



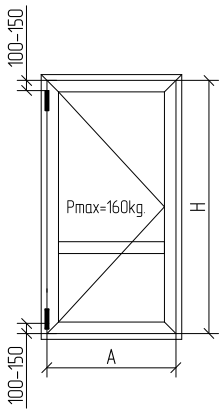
ALUTECH

Table of max. allowed door leaf weight

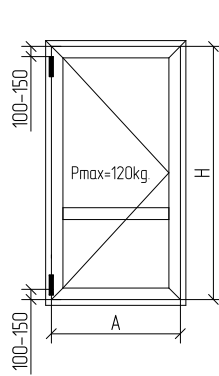


The loads are given without door closer using.
With door closer:
face-mounted $P=0,6 \times P_{max}$; hidden $P=0,8 \times P_{max}$.

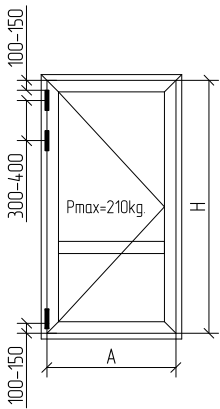
With door leaf height more than 2200mm - 3-d hinge in the middle is obligatory.



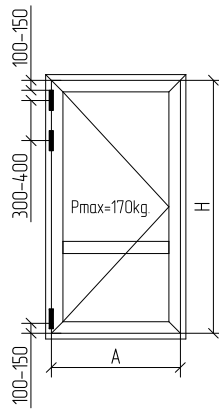
		2 Hinges							
2500	160	160	160	160	160	160	160	160	160
2400	160	160	160	160	160	160	160	160	160
2300	160	160	160	160	160	160	160	160	160
2200	160	160	160	160	160	160	160	160	160
2100	160	160	160	160	160	160	160	160	160
2000	160	160	160	160	160	160	160	160	160
1900	160	160	160	160	160	160	160	160	160
1800	160	160	160	160	160	160	160	160	150
1700	160	160	160	160	160	160	150	140	140
1600	160	160	160	160	160	150	150	160	150
1500	160	160	160	160	150	140	130	120	120
1400	160	160	160	150	140	130	120	110	110
1300	160	160	150	140	130	120	110	100	100
1200	160	150	140	130	120	110	100	90	90
H x A	600	700	800	900	1000	1100	1200	1300	A



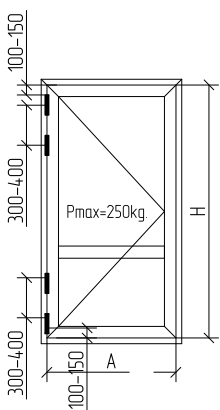
		2 Hinges							
2500	120	120	120	120	120	120	120	120	120
2400	120	120	120	120	120	120	120	120	120
2300	120	120	120	120	120	120	120	120	120
2200	120	120	120	120	120	120	120	120	120
2100	120	120	120	120	120	120	120	120	120
2000	120	120	120	120	120	120	120	120	120
1900	120	120	120	120	120	120	120	120	120
1800	120	120	120	120	120	120	120	120	110
1700	120	120	120	120	120	120	120	110	100
1600	120	120	120	120	120	120	110	120	110
1500	120	120	120	120	110	100	90	80	80
1400	120	120	120	110	100	90	80	70	70
1300	120	120	110	100	90	80	70	60	60
1200	120	110	100	90	80	70	60	50	50
H x A	600	700	800	900	1000	1100	1200	1300	A



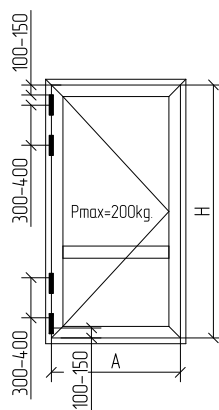
		3 Hinges							
2500	210	210	210	210	210	210	210	210	210
2400	210	210	210	210	210	210	210	210	210
2300	210	210	210	210	210	210	210	210	210
2200	210	210	210	210	210	210	210	210	210
2100	210	210	210	210	210	210	210	210	210
2000	210	210	210	210	210	210	210	210	210
1900	210	210	210	210	210	210	210	210	210
1800	210	210	210	210	210	210	210	210	197
1700	210	210	210	210	210	210	197	184	184
1600	210	210	210	210	210	197	210	197	197
1500	210	210	210	210	197	184	171	158	158
1400	210	210	210	197	184	171	158	144	144
1300	210	210	197	184	171	158	144	131	131
1200	210	197	184	171	158	144	131	118	118
H x A	600	700	800	900	1000	1100	1200	1300	A



		3 Hinges							
2500	170	170	170	170	170	170	170	170	170
2400	170	170	170	170	170	170	170	170	170
2300	170	170	170	170	170	170	170	170	170
2200	170	170	170	170	170	170	170	170	170
2100	170	170	170	170	170	170	170	170	170
2000	170	170	170	170	170	170	170	170	170
1900	170	170	170	170	170	170	170	170	170
1800	170	170	170	170	170	170	170	170	157
1700	170	170	170	170	170	170	157	144	144
1600	170	170	170	170	170	157	170	157	157
1500	170	170	170	170	157	144	131	118	118
1400	170	170	170	157	144	131	118	104	104
1300	170	170	157	144	131	118	104	91	91
1200	170	157	144	131	118	104	91	78	78
H x A	600	700	800	900	1000	1100	1200	1300	A

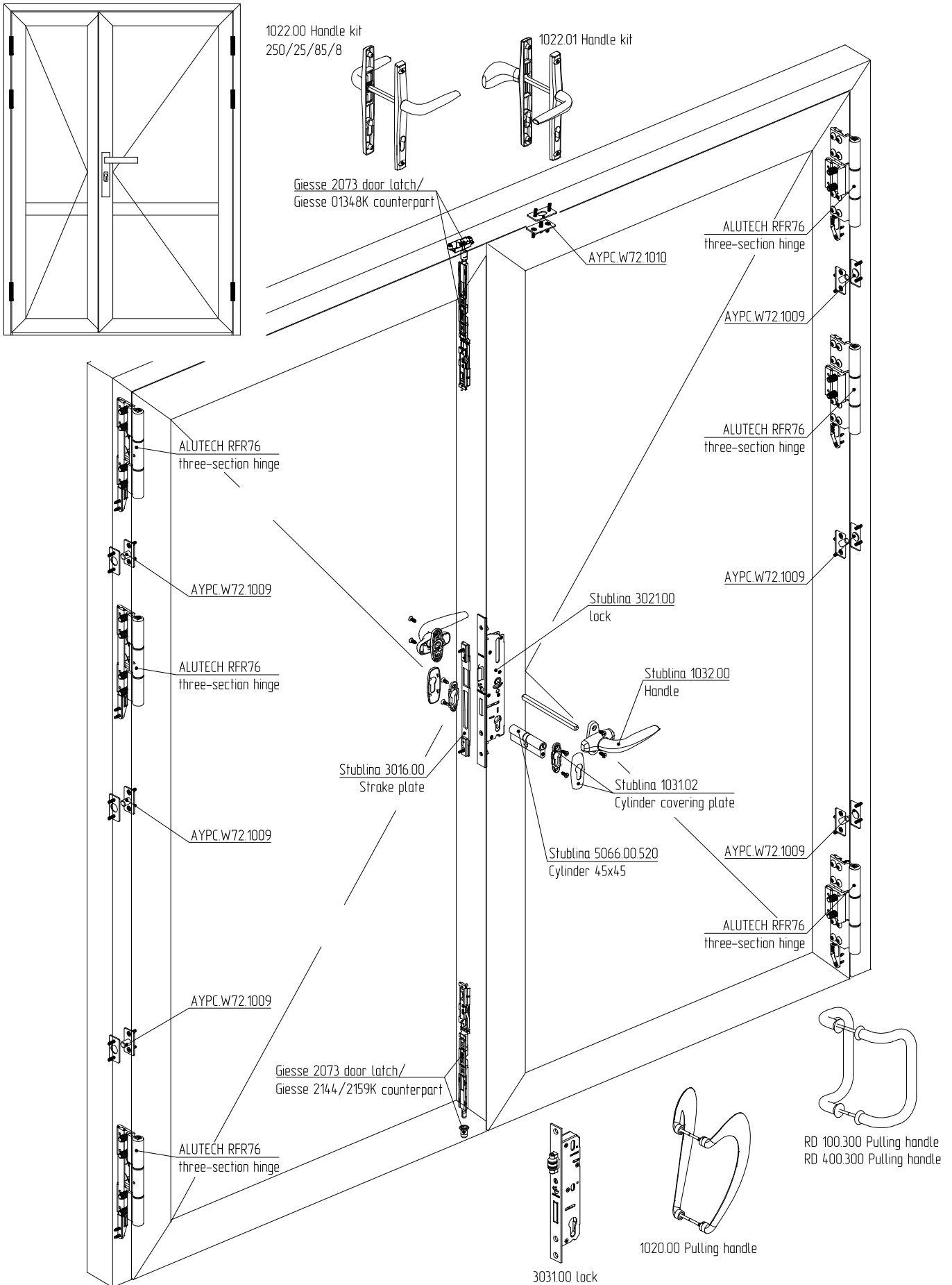


		4 Hinges							
2500	250	250	250	250	250	250	250	250	250
2400	250	250	250	250	250	250	250	250	250
2300	250	250	250	250	250	250	250	250	250
2200	250	250	250	250	250	250	250	250	250
2100	250	250	250	250	250	250	250	250	250
2000	250	250	250	250	250	250	250	250	250
1900	250	250	250	250	250	250	250	250	250
1800	250	250	250	250	250	250	250	250	234
1700	250	250	250	250	250	250	234	219	219
1600	250	250	250	250	250	234	250	234	234
1500	250	250	250	250	234	219	203	188	188
1400	250	250	250	234	219	203	188	172	172
1300	250	250	234	219	203	188	172	156	156
1200	250	234	219	203	188	172	156	141	141
H x A	600	700	800	900	1000	1100	1200	1300	A

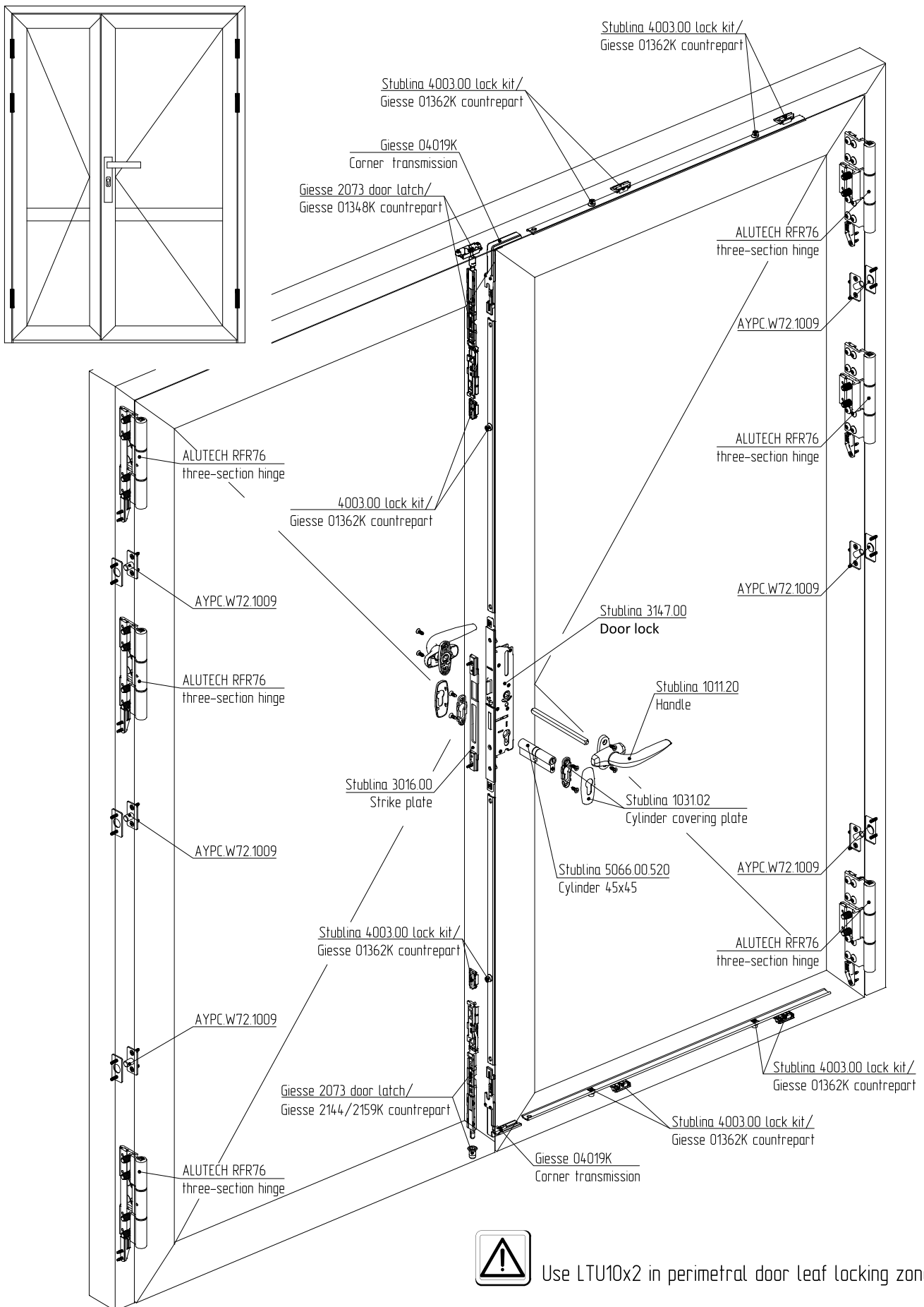


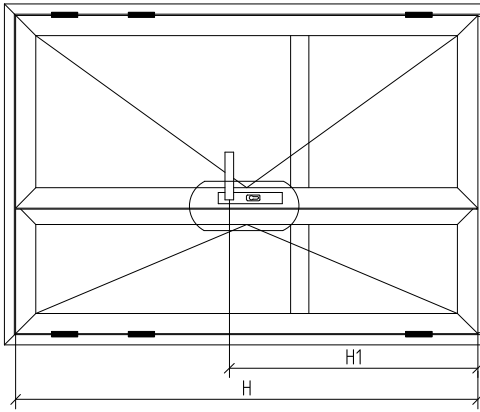
		4 Hinges							
2500	200	200	200	200	200	200	200	200	200
2400	200	200	200	200	200	200	200	200	200
2300	200	200	200	200	200	200	200	200	200
2200	200	200	200	200	200	200	200	200	200
2100	200	200	200	200	200	200	200	200	200
2000	200	200	200	200	200	200	200	200	200
1900	200	200	200	200	200	200	200	200	200
1800	200	200	200	200	200	200	200	200	184
1700	200	200	200	200	200	200	184	169	169
1600	200	200	200	200	200	184	200	184	184
1500	200	200	200	200	184	169	153	138	138
1400	200	200	200	184	169	153	138	122	122
1300	200	200	184	169	153	138	122	106	106
1200	200	184	169	153	138	122	106	91	91
H x A	600	700	800	900	1000	1100	1200	1300	A

Solution of door system without perimential locking



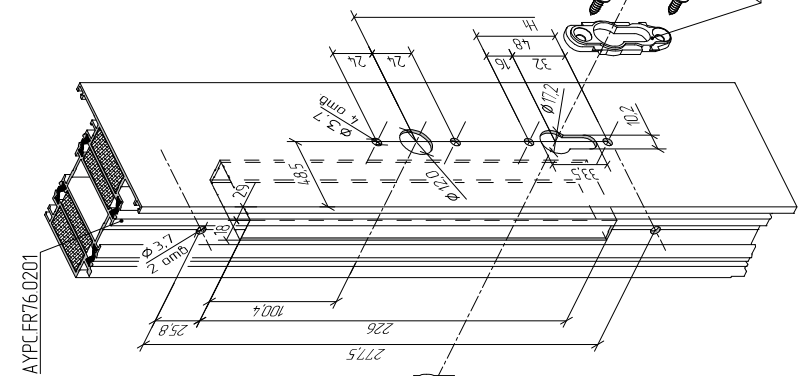
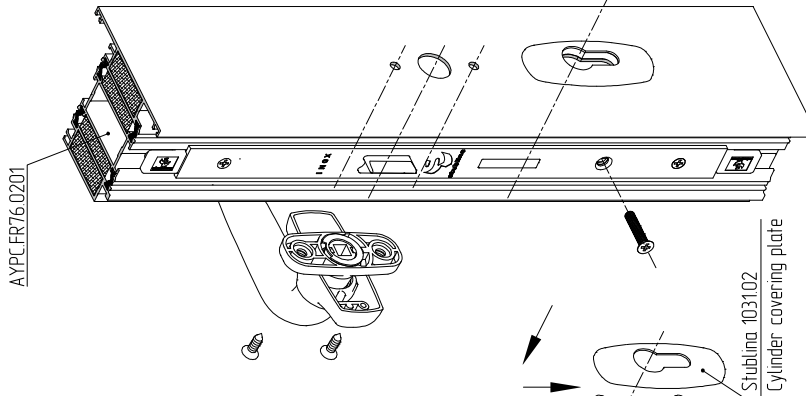
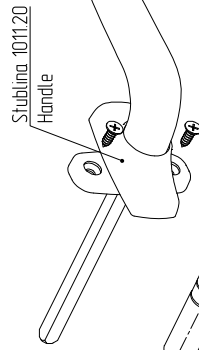
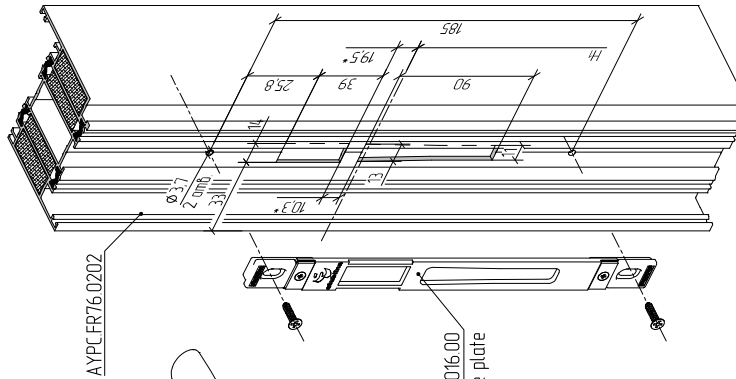
Solution of door system with perimtral locking





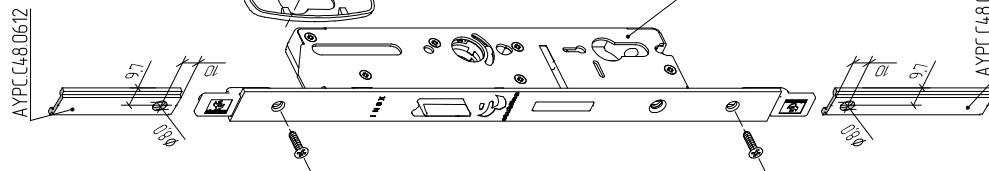
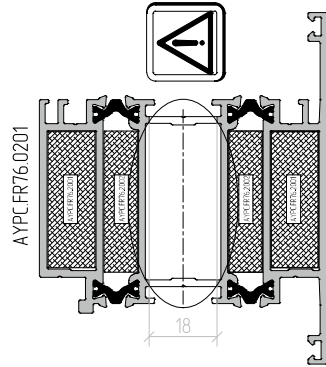
H – door leaf height
H1 – distance from door leaf bottom to handle axis

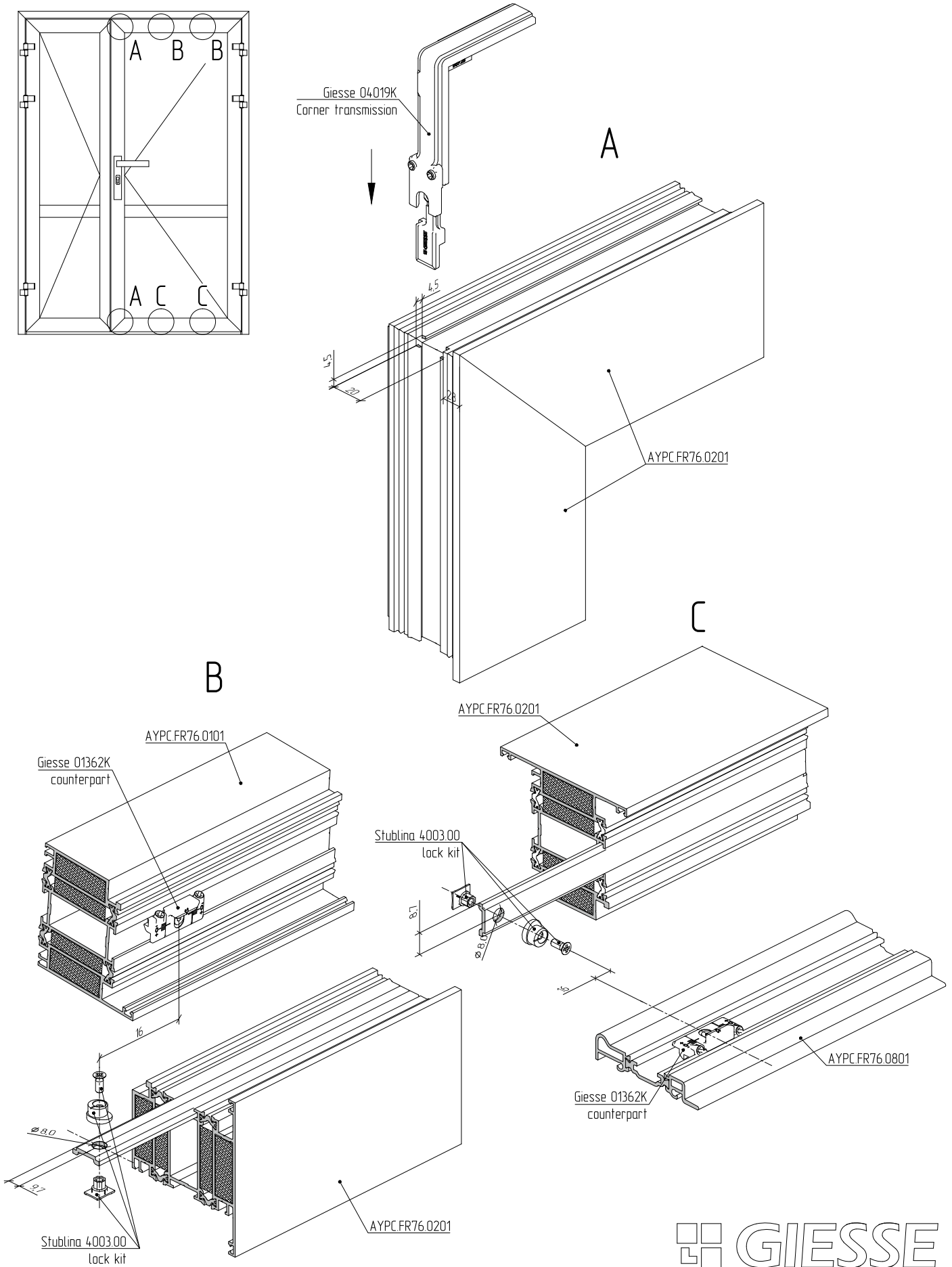
*dimensions for reference. Determine after lock installation



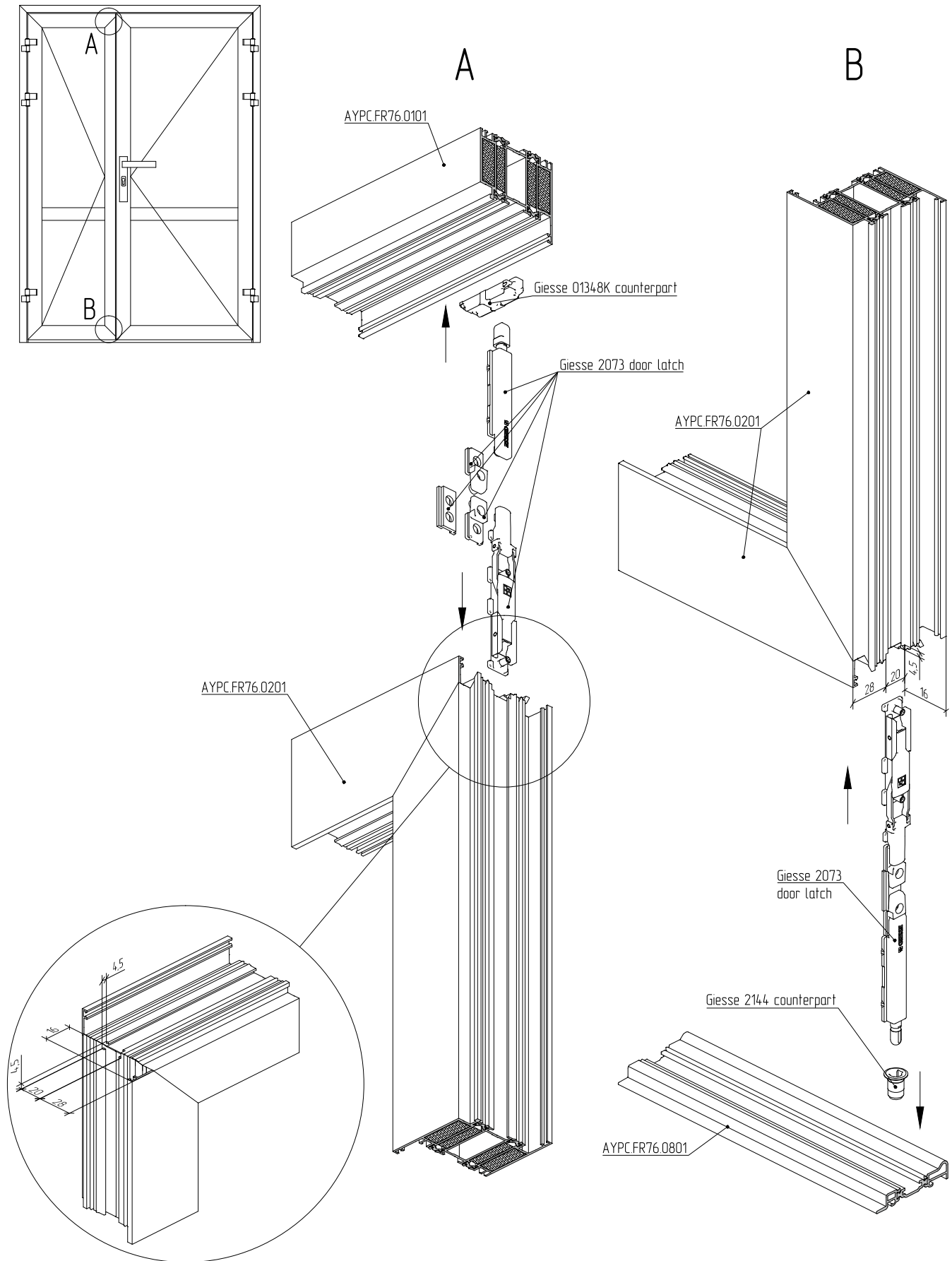
Before cylinder, it's necessary to install 103102 covering plates.

For Stublina 314.700 lock installation, through milling of intermediate profile is necessary

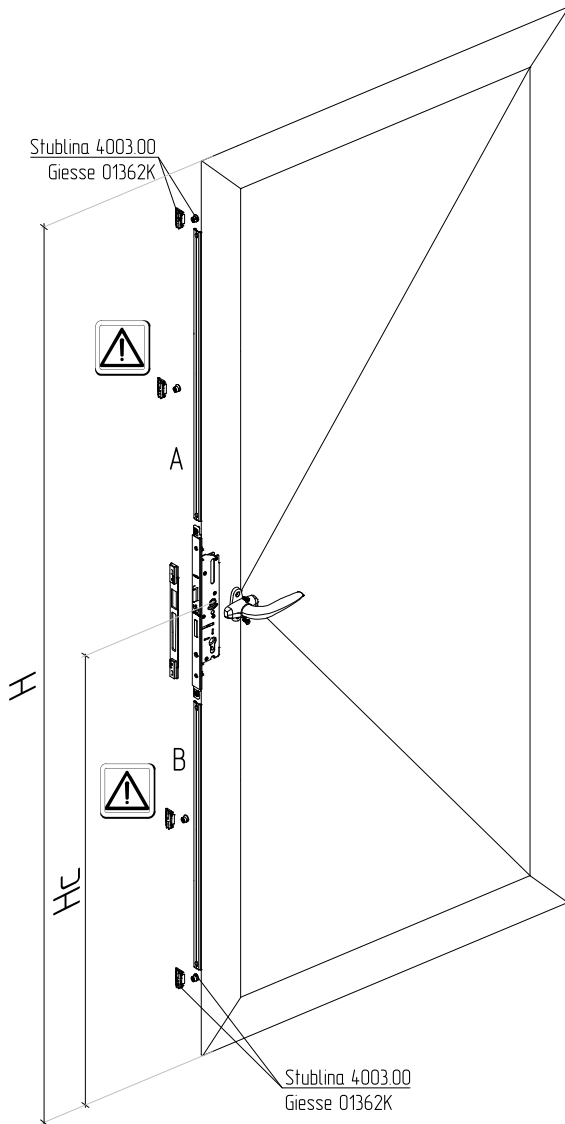




GIESSE



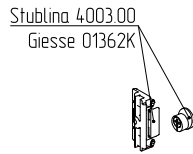
Scheme of calculation and installation of active door leaf perimetral locking



It's recommended in case of door leaf width $L \leq 800$ mm.

$$A = H - Hc - 450$$

$$B = Hc - 474$$



In case of rod length ≥ 1000 mm, it's recommended to install additional lock element in the middle.

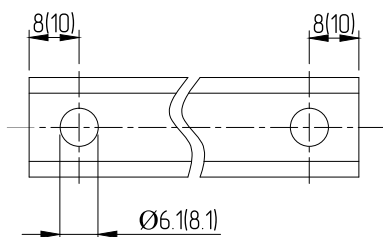
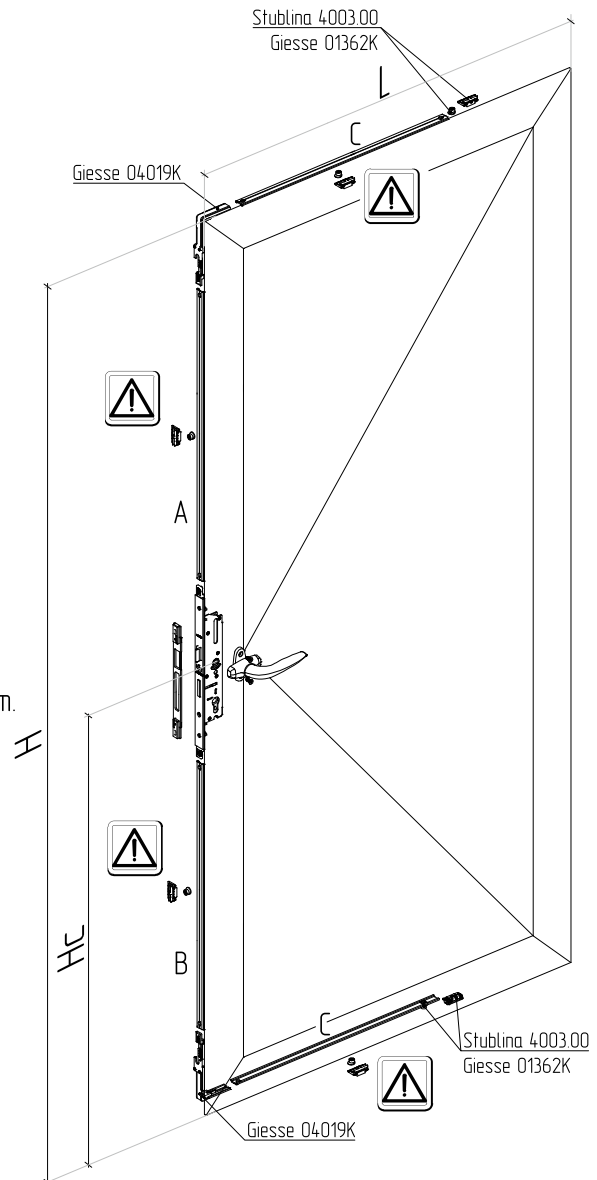


It's recommended in case of door leaf width $L \geq 800$ mm.

$$A = H - Hc - 306$$

$$B = Hc - 330$$

$$C = L/2 - 52$$



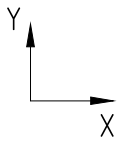


ALT FR76
FIRE RESISTANT
DOORS WITH DOUBLE
THERMAL BREAK

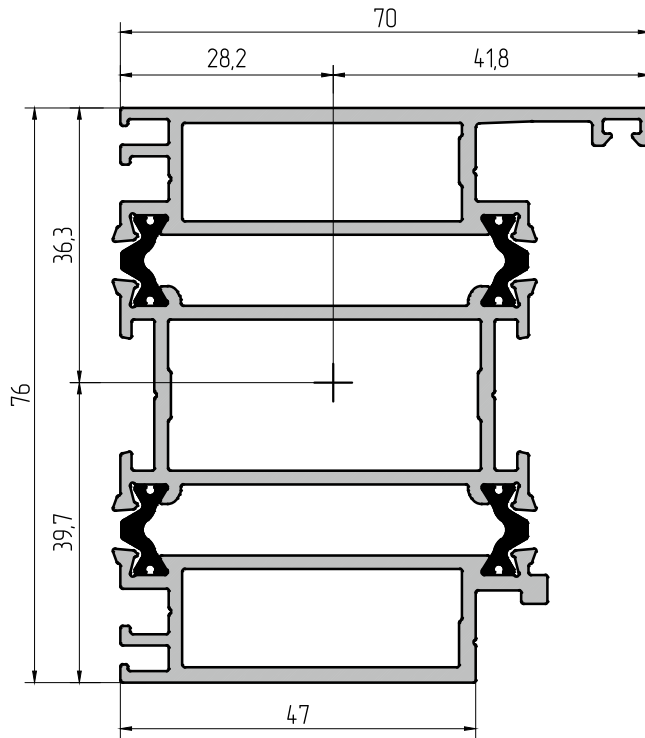
STATICS

09

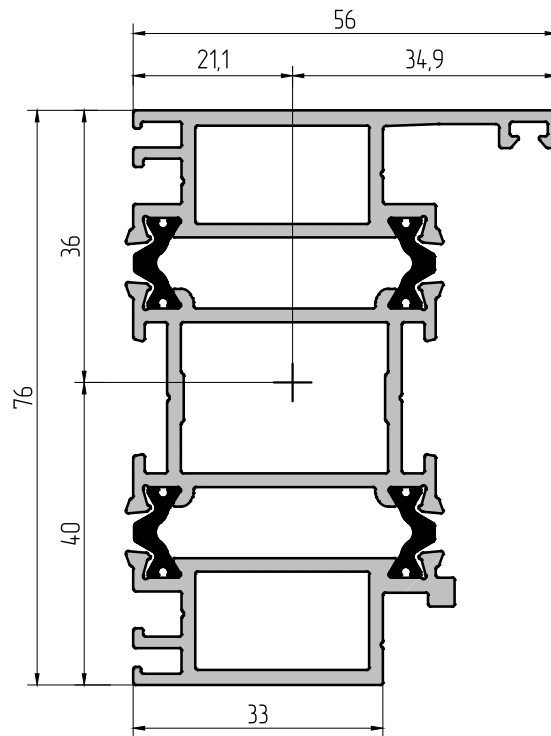
Geometric profiles characteristics



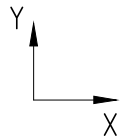
AYPC.FR76.0101



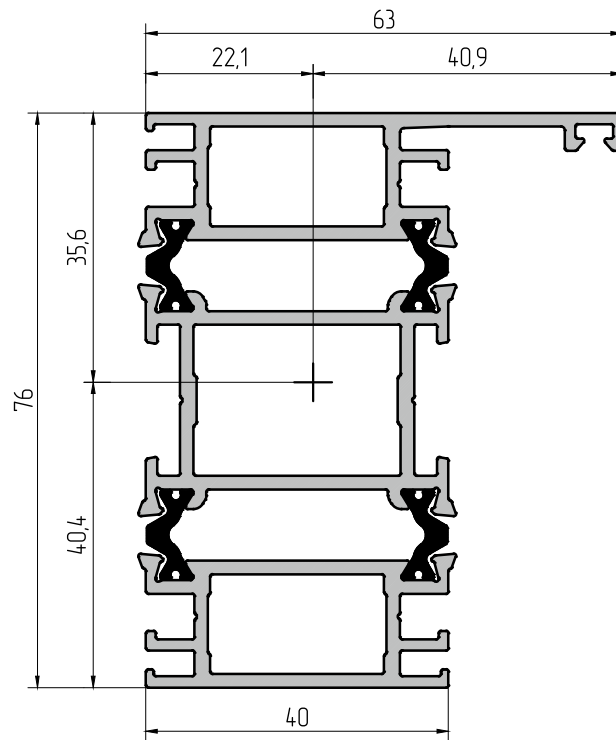
AYPC.FR76.0102



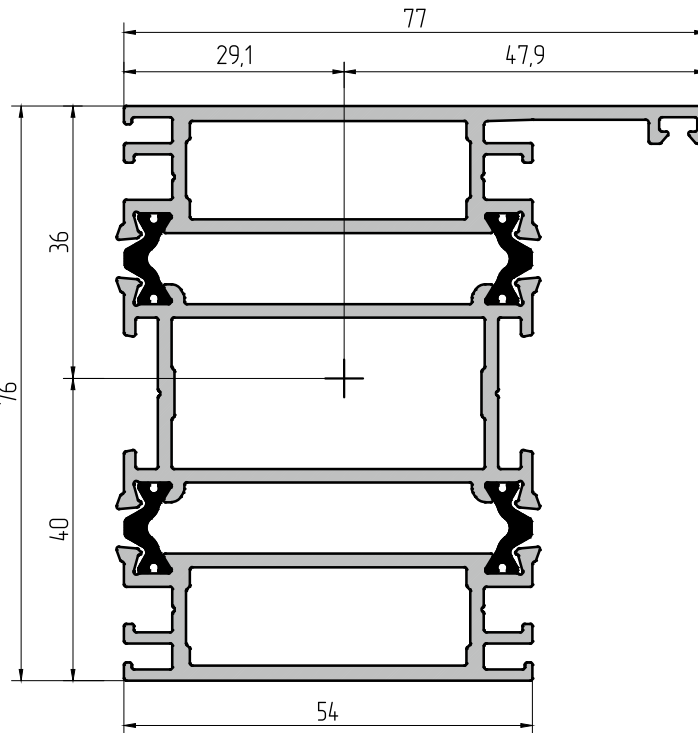
Profile	w, kg/m	S, mm ²	Jx, cm ⁴	Wx, cm ³	ax, mm	Jy, cm ⁴	Wy, cm ³	ay, mm
AYPC.FR76.0101	2,72	1070	44,4	11,2	39,7	34,3	8,2	41,8
AYPC.FR76.0102	2,27	908	35,8	8,9	40	16,1	4,6	34,9



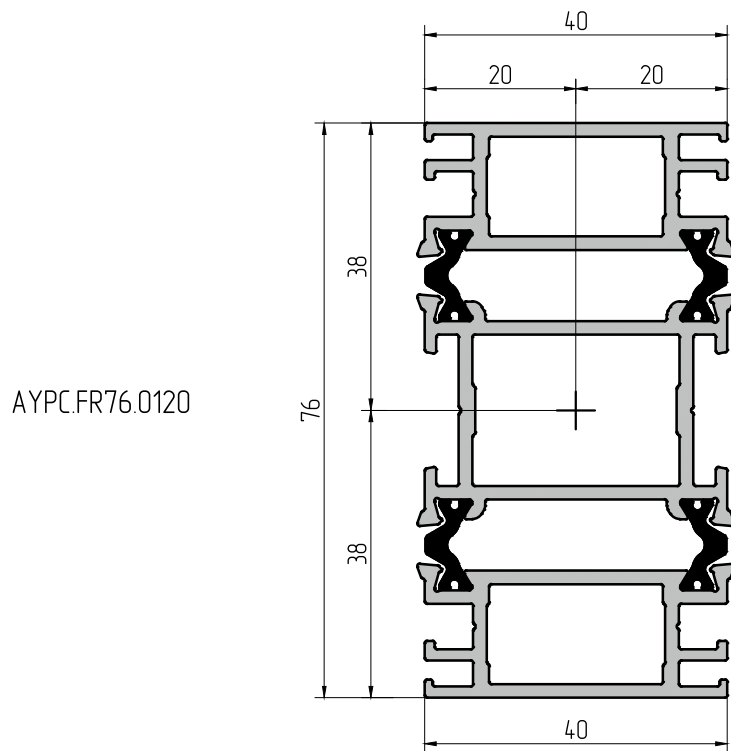
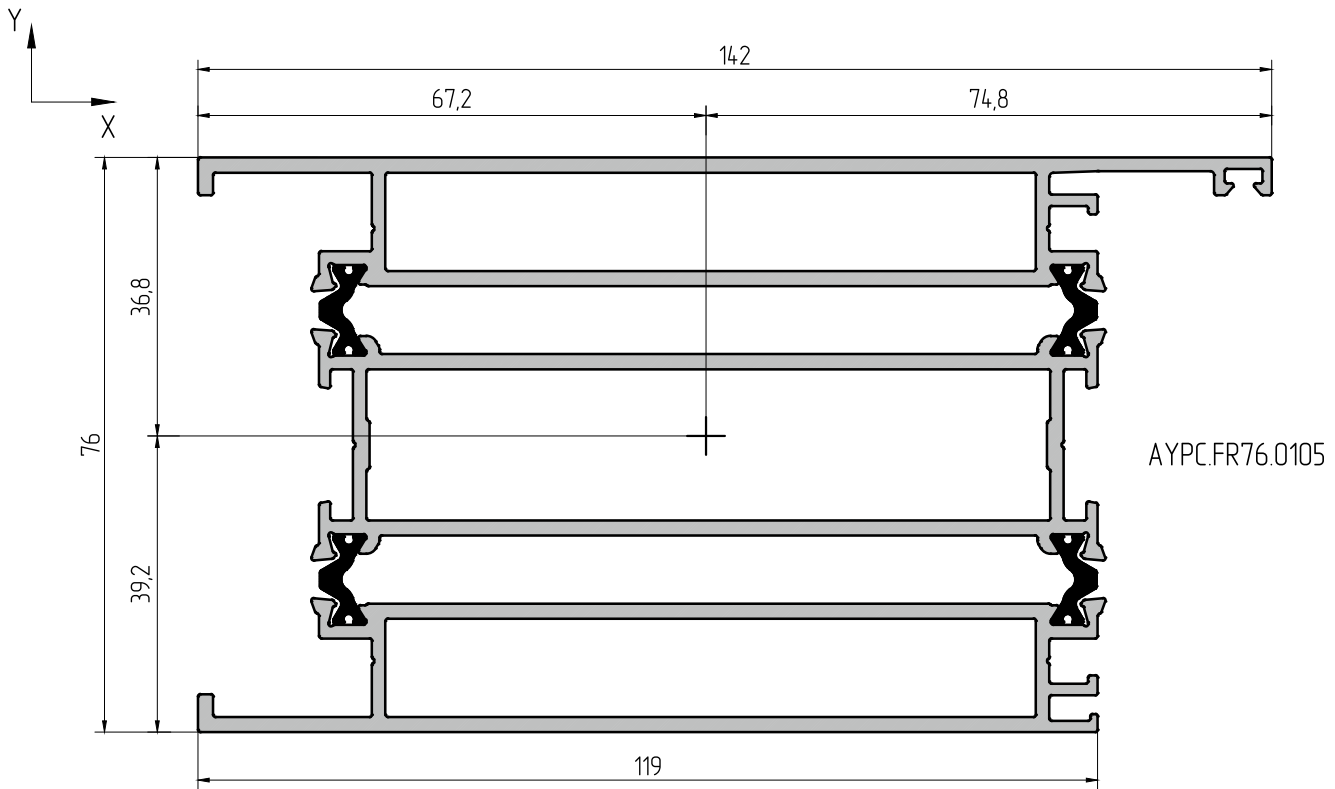
AYPC.FR76.0103



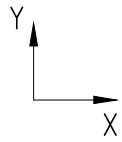
AYPC.FR76.0104



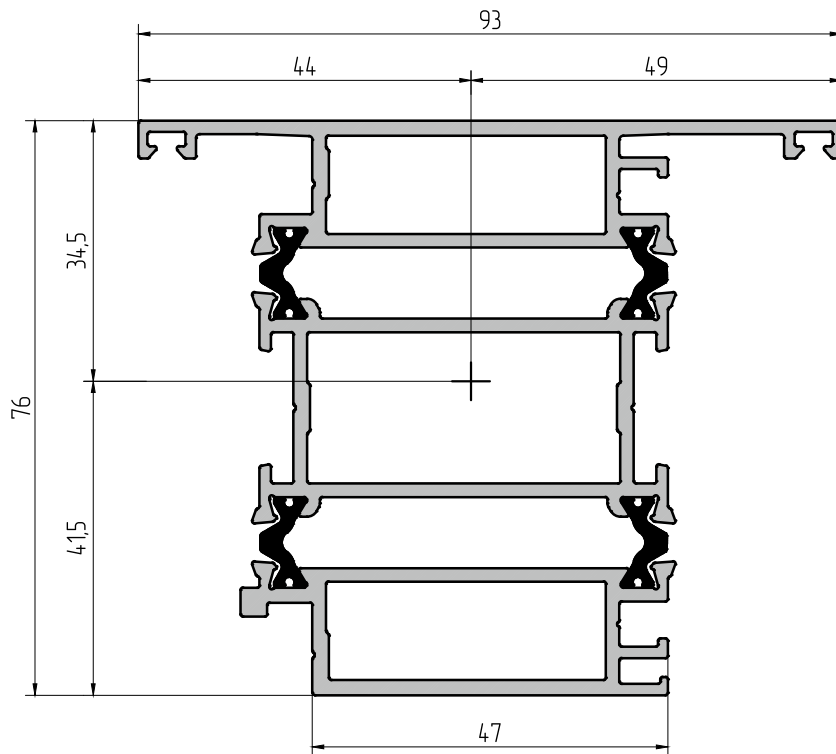
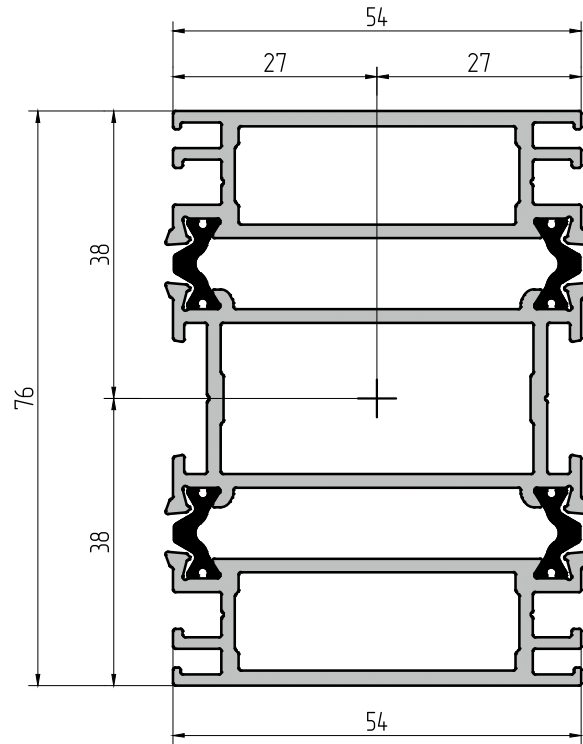
Profile	w, kg/m	S, mm ²	Jx, cm ⁴	Wx, cm ³	ax, mm	Jy, cm ⁴	Wy, cm ³	ay, mm
AYPC.FR76.0103	2,35	936	38,7	9,6	40,4	18,8	4,6	40,9
AYPC.FR76.0104	2,81	1106	48,1	12	40	38,4	8	47,9



Profile	w, kg/m	S, mm ²	Jx, cm ⁴	Wx, cm ³	ax, mm	Jy, cm ⁴	Wy, cm ³	ay, mm
AYPC.FR76.0105	4,62	1777	83,7	21,4	39,2	219,3	29,3	74,8
AYPC.FR76.0120	2,2	883	33,8	8,9	38	13,4	6,7	20

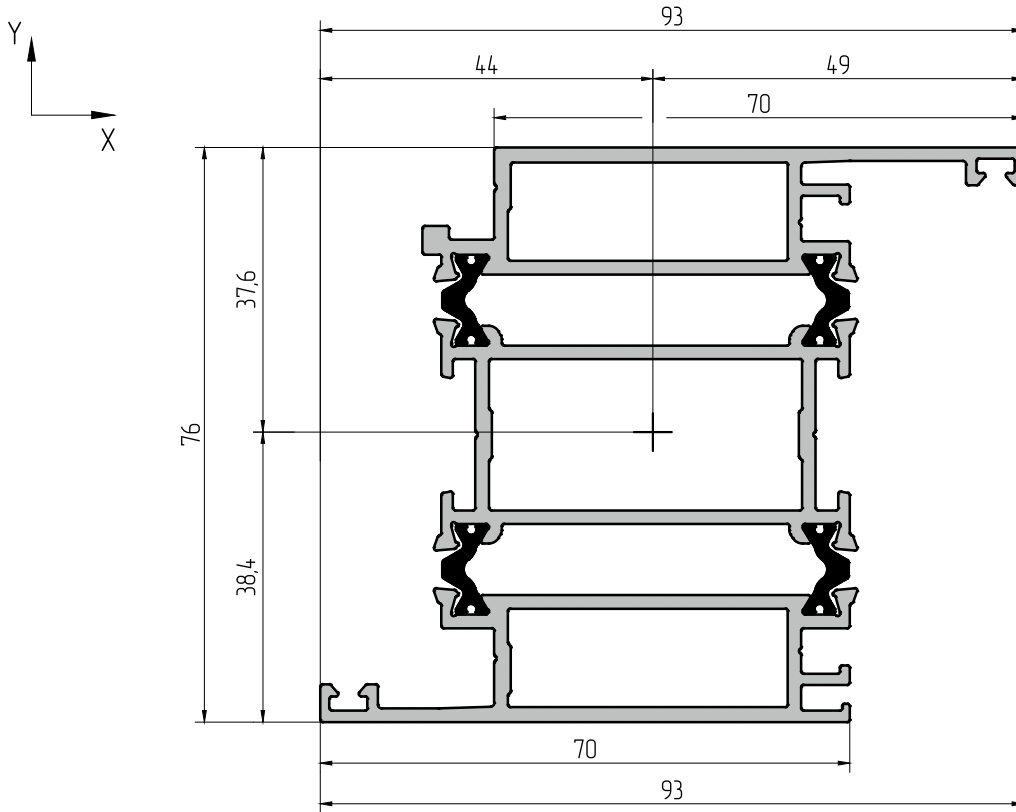


AYPC.FR76.0121

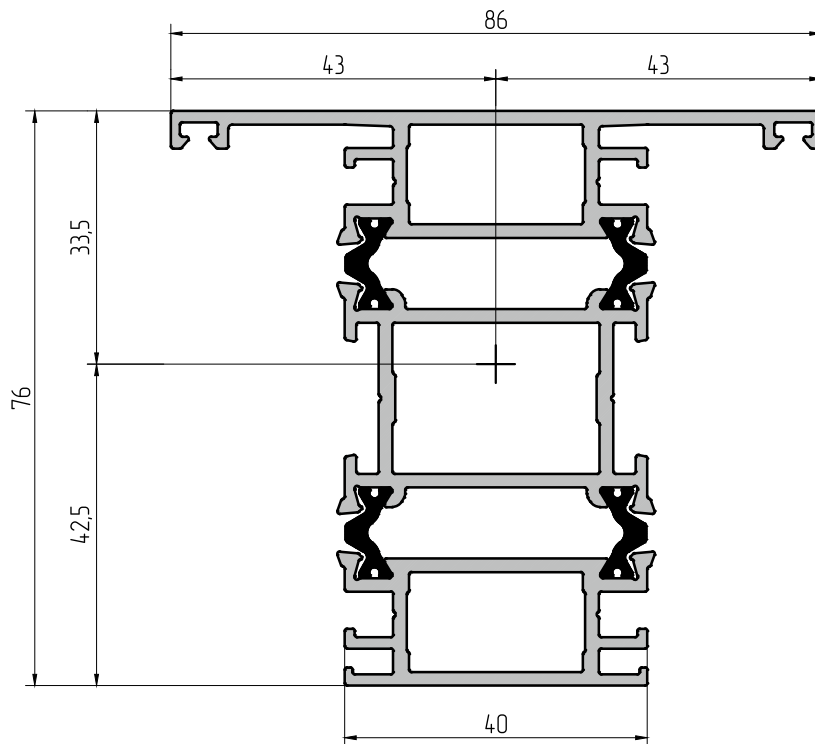


AYPC.FR76.0201

Profile	w, kg/m	S, mm ²	Jx, cm ⁴	Wx, cm ³	ax, mm	Jy, cm ⁴	Wy, cm ³	ay, mm
AYPC.FR76.0121	2,67	1054	43,1	11,3	38	30,4	11,2	27
AYPC.FR76.0201	2,86	1123,1	48,9	11,8	41,5	42,6	8,7	49

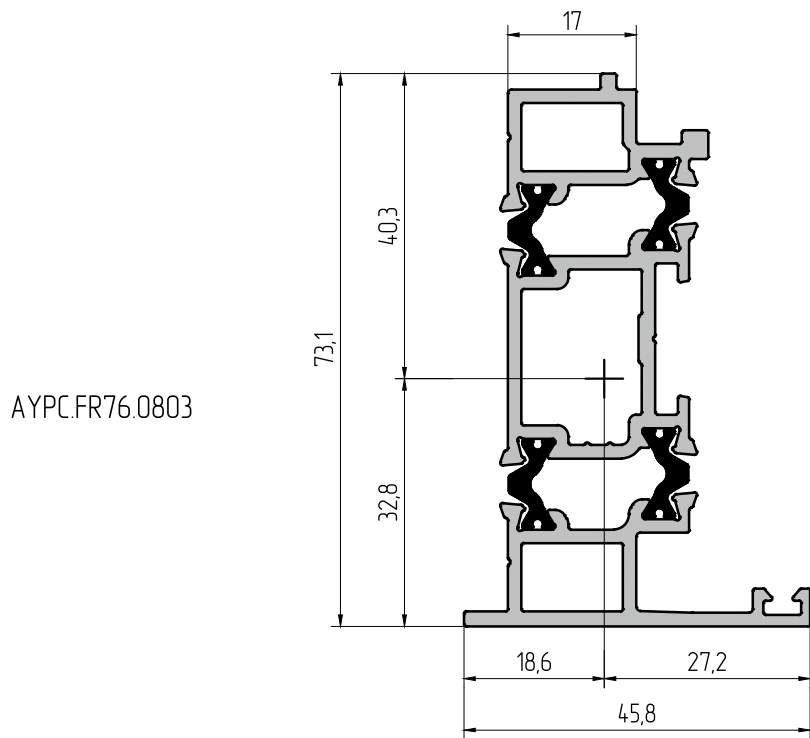
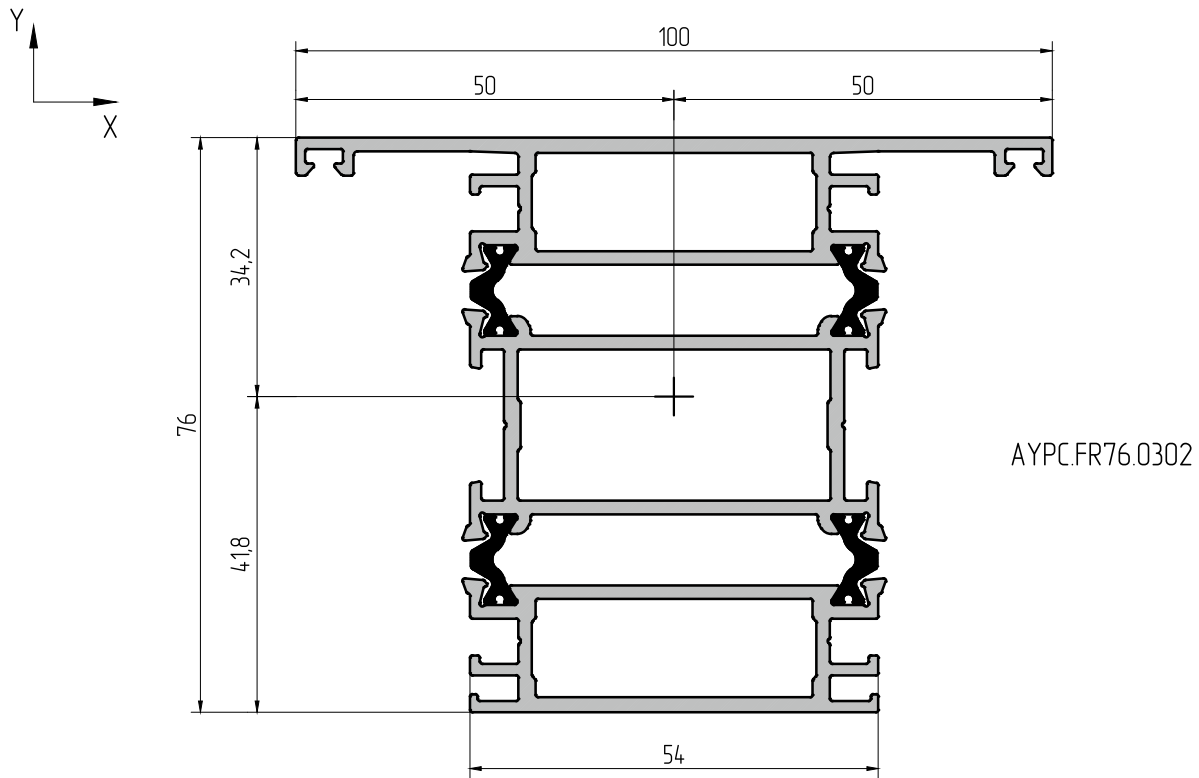


AYPC.FR76.0202



AYPC.FR76.0301

Profile	w, kg/m	S, mm ²	Jx, cm ⁴	Wx, cm ³	ax, mm	Jy, cm ⁴	Wy, cm ³	ay, mm
AYPC.FR76.0202	2,86	1123,1	49,8	12,9	38,4	42,6	8,7	49
AYPC.FR76.0301	2,49	989	43,1	10,1	42,5	24,9	5,8	43



Profile	w, kg/m	S, mm ²	Jx, cm ⁴	Wx, cm ³	ax, mm	Jy, cm ⁴	Wy, cm ³	ay, mm
AYPC.FR76.0302	2,95	1159	52,6	12,6	41,8	47,2	9,4	50
AYPC.FR76.0803	1,7	695	23,3	5,8	40,3	5,3	1,9	27,2



The ALT FR76 profile system is designed for manufacturing of fire resistant exterior and interior doors and partitions in premises with high fire resistance requirements EIW30, EIW45 and EIW60.

The main advantage of the system is the innovative five-chamber profiles configuration allowing to achieve same fireproofing parameters from the inside and from the outside of the door, as well as to manufacture EIW30 doors without using fire resistant inserts.

AluminTechno JLLC
 tel.: +375 17 345 81 43, 45,
 fax: +375 17 345 81 48
 e-mail: market@alt.by

Certificate № 800017207
 issued by the Ministry of Foreign Affairs
 of the Republic of Belarus
 03.12.2002 № 800017207

